

CONCLUSIONES

1. Al realizar el proyecto nos hemos familiarizado con los micro controladores de la familia ATMEL conociendo las características para su correcto funcionamiento de igual forma se pudo trabajar con las herramientas que ofrece el AVR studio 4, para programar este tipo de micro controladores conociendo las beneficios y limitaciones del robot pololu 3pi y el Butterfly.
2. El Robot Pololu es un dispositivo muy útil en el campo de la Robótica ya que este puede realizar recorridos evitando obstáculos siguiendo a un móvil o no y puede ser controlado inalámbricamente o vía remota.
3. El Kit AVR Butterfly es una poderosa herramienta de aprendizaje, es práctico, eficaz y muy amigable; que con el desarrollo del proyecto se va descubriendo progresivamente las características del micro controlador ATmega169.

RECOMENDACIONES

1. Es necesario revisar las hojas de especificaciones antes de trabajar con los dispositivos y en el caso de el Butterfly y el Robot Pololu revisar su user guide ya que ahí dan las recomendaciones para trabajar con ellos.
2. Es recomendable que las baterías para que el pololu trabaje este bien cargadas ya que este puede no permitir grabar bien el programa o más aun que el programador se quemé.
3. Fijar bien las frecuencias de trabajo para que el butterfly como para el pololu pueda transmitir, ya que si ambas no tienen igual frecuencias no transmite y entonces el robot no se mueve

ANEXOS

ANEXOS 1

ESPECIFICACIONES Y DIAGRAMAS DEL MICROCONTROLADOR ATMEGA 328

Features

- High Performance, Low Power AVR[®] 8-Bit Microcontroller
- Advanced RISC Architecture
 - 131 Powerful Instructions – Most Single Clock Cycle Execution
 - 32 x 8 General Purpose Working Registers
 - Fully Static Operation
 - Up to 20 MIPS Throughput at 20 MHz
 - On-chip 2-cycle Multiplier
- High Endurance Non-volatile Memory Segments
 - 4/8/16/32K Bytes of In-System Self-Programmable Flash program memory (ATmega48PA/88PA/168PA/328P)
 - 256/512/512/1K Bytes EEPROM (ATmega48PA/88PA/168PA/328P)
 - 512/1K/1K/2K Bytes Internal SRAM (ATmega48PA/88PA/168PA/328P)
 - Write/Erase Cycles: 10,000 Flash/100,000 EEPROM
 - Data retention: 20 years at 85°C/100 years at 25°C⁽¹⁾
 - Optional Boot Code Section with Independent Lock Bits
 - In-System Programming by On-chip Boot Program
 - True Read-While-Write Operation
 - Programming Lock for Software Security
- Peripheral Features
 - Two 8-bit Timer/Counters with Separate Prescaler and Compare Mode
 - One 16-bit Timer/Counter with Separate Prescaler, Compare Mode, and Capture Mode
 - Real Time Counter with Separate Oscillator
 - Six PWM Channels
 - 8-channel 10-bit ADC in TQFP and QFN/MLF package
 - Temperature Measurement
 - 6-channel 10-bit ADC in PDIP Package
 - Temperature Measurement
 - Programmable Serial USART
 - Master/Slave SPI Serial Interface
 - Byte-oriented 2-wire Serial Interface (Philips I²C compatible)
 - Programmable Watchdog Timer with Separate On-chip Oscillator
 - On-chip Analog Comparator
 - Interrupt and Wake-up on Pin Change
- Special Microcontroller Features
 - Power-on Reset and Programmable Brown-out Detection
 - Internal Calibrated Oscillator
 - External and Internal Interrupt Sources
 - Six Sleep Modes: Idle, ADC Noise Reduction, Power-save, Power-down, Standby, and Extended Standby
- I/O and Packages
 - 23 Programmable I/O Lines
 - 28-pin PDIP, 32-lead TQFP, 28-pad QFN/MLF and 32-pad QFN/MLF
- Operating Voltage:
 - 1.8 - 5.5V for ATmega48PA/88PA/168PA/328P
- Temperature Range:
 - -40°C to 85°C
- Speed Grade:
 - 0 - 20 MHz @ 1.8 - 5.5V
- Low Power Consumption at 1 MHz, 1.8V, 25°C for ATmega48PA/88PA/168PA/328P:
 - Active Mode: 0.2 mA
 - Power-down Mode: 0.1 µA
 - Power-save Mode: 0.75 µA (Including 32 kHz RTC)



8-bit **AVR[®]**
Microcontroller
with 4/8/16/32K
Bytes In-System
Programmable
Flash

ATmega48PA
ATmega88PA
ATmega168PA
ATmega328P

Rev. 8161D-AVR-10/09



1. Pin Configurations

Figure 1-1. Pinout ATmega48PA/88PA/168PA/328P

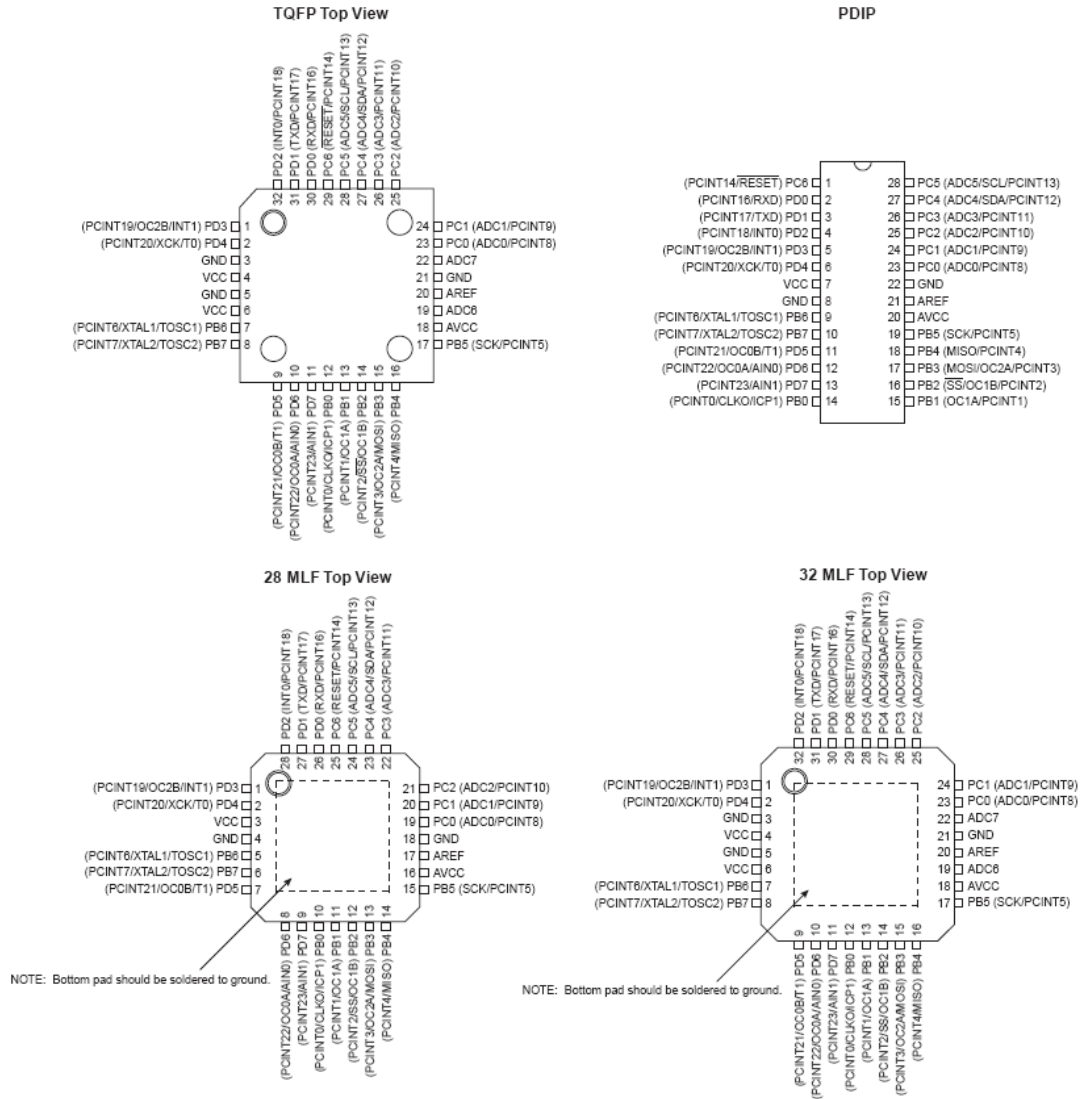

2.1 Block Diagram

Figure 2-1. Block Diagram

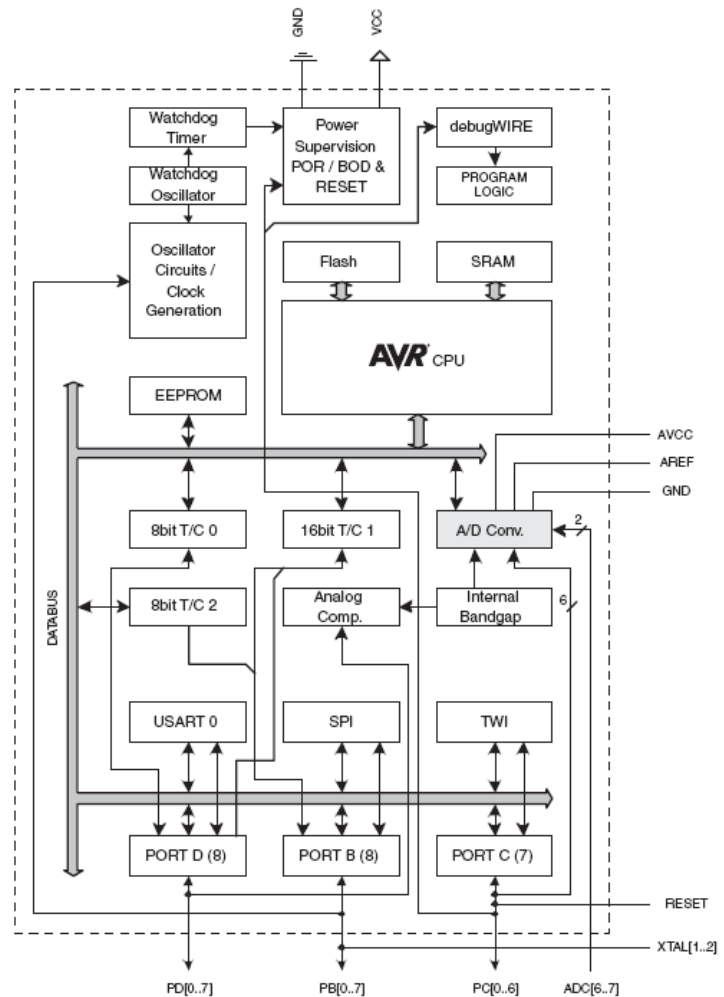

The AVR core combines a rich instruction set with 32 general purpose working registers. All the 32 registers are directly connected to the Arithmetic Logic Unit (ALU), allowing two independent registers to be accessed in one single instruction executed in one clock cycle. The resulting

Diagrama de Bloques del microcontrolador Atmega 328

ANEXOS 2

ESPECIFICACIONES Y DIAGRAMAS DEL MICROCONTROLADOR ATMEGA 169

Features

- High Performance, Low Power AVR[®] 8-Bit Microcontroller
- Advanced RISC Architecture
 - 130 Powerful Instructions – Most Single Clock Cycle Execution
 - 32 x 8 General Purpose Working Registers
 - Fully Static Operation
 - Up to 16 MIPS Throughput at 16 MHz
 - On-Chip 2-cycle Multiplier
- Non-volatile Program and Data Memories
 - 16K bytes of In-System Self-Programmable Flash
Endurance: 10,000 Write/Erase Cycles
 - Optional Boot Code Section with Independent Lock Bits
In-System Programming by On-chip Boot Program
True Read-While-Write Operation
 - 512 bytes EEPROM
Endurance: 100,000 Write/Erase Cycles
 - 1K byte Internal SRAM
 - Programming Lock for Software Security
- JTAG (IEEE std. 1149.1 compliant) Interface
 - Boundary-scan Capabilities According to the JTAG Standard
 - Extensive On-chip Debug Support
 - Programming of Flash, EEPROM, Fuses, and Lock Bits through the JTAG Interface
- Peripheral Features
 - 4 x 25 Segment LCD Driver
 - Two 8-bit Timer/Counters with Separate Prescaler and Compare Mode
 - One 16-bit Timer/Counter with Separate Prescaler, Compare Mode, and Capture Mode
 - Real Time Counter with Separate Oscillator
 - Four PWM Channels
 - 8-channel, 10-bit ADC
 - Programmable Serial USART
 - Master/Slave SPI Serial Interface
 - Universal Serial Interface with Start Condition Detector
 - Programmable Watchdog Timer with Separate On-chip Oscillator
 - On-chip Analog Comparator
 - Interrupt and Wake-up on Pin Change
- Special Microcontroller Features
 - Power-on Reset and Programmable Brown-out Detection
 - Internal Calibrated Oscillator
 - External and Internal Interrupt Sources
 - Five Sleep Modes: Idle, ADC Noise Reduction, Power-save, Power-down, and Standby
- I/O and Packages
 - 53 Programmable I/O Lines
 - 64-lead TQFP and 64-pad QFN/MLF
- Speed Grade:
 - ATmega169V: 0 - 4 MHz @ 1.8 - 5.5V, 0 - 8 MHz @ 2.7 - 5.5V
 - ATmega169: 0 - 8 MHz @ 2.7 - 5.5V, 0 - 16 MHz @ 4.5 - 5.5V
- Temperature range:
 - -40°C to 85°C Industrial
- Ultra-Low Power Consumption
 - Active Mode:
 - 1 MHz, 1.8V: 350µA
 - 32 kHz, 1.8V: 20µA (including Oscillator)
 - 32 kHz, 1.8V: 40µA (including Oscillator and LCD)
 - Power-down Mode:
 - 0.1µA at 1.8V



8-bit AVR[®]
Microcontroller
with 16K Bytes
In-System
Programmable
Flash

ATmega169V
ATmega169

Notice:
Not recommended in new
designs.

2514P-AVR-07/06



Pin Configurations

Figure 1. Pinout ATmega169

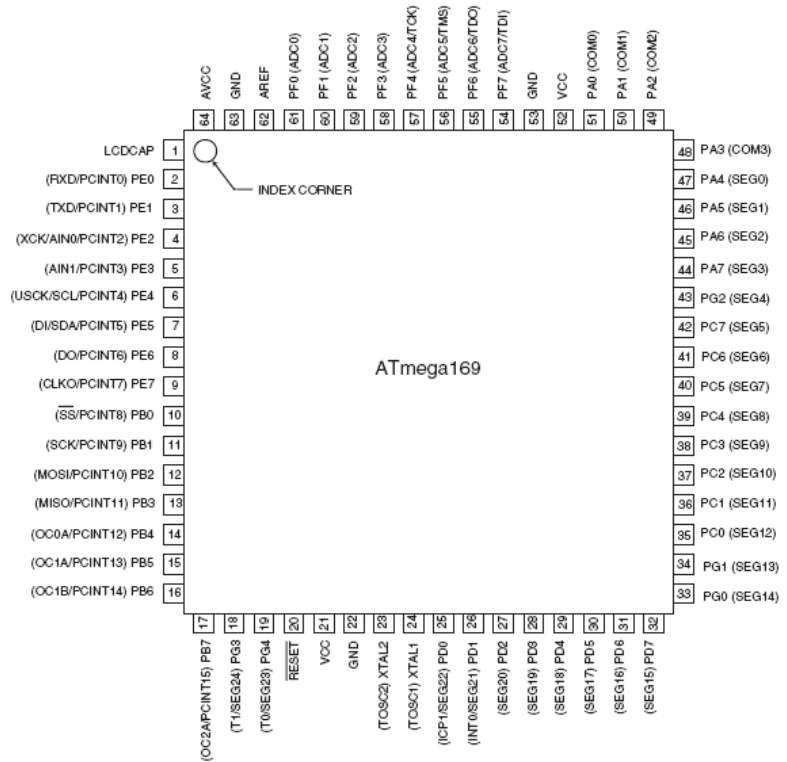

Note: The large center pad underneath the QFN/MLF packages is made of metal and internally connected to GND. It should be soldered or glued to the board to ensure good mechanical stability. If the center pad is left unconnected, the package might loosen from the board.

Disclaimer

Typical values contained in this datasheet are based on simulations and characterization of other AVR microcontrollers manufactured on the same process technology. Min and Max values will be available after the device is characterized.

Overview

The ATmega169 is a low-power CMOS 8-bit microcontroller based on the AVR enhanced RISC architecture. By executing powerful instructions in a single clock cycle, the ATmega169 achieves throughputs approaching 1 MIPS per MHz allowing the system designer to optimize power consumption versus processing speed.

Block Diagram

Figure 2. Block Diagram

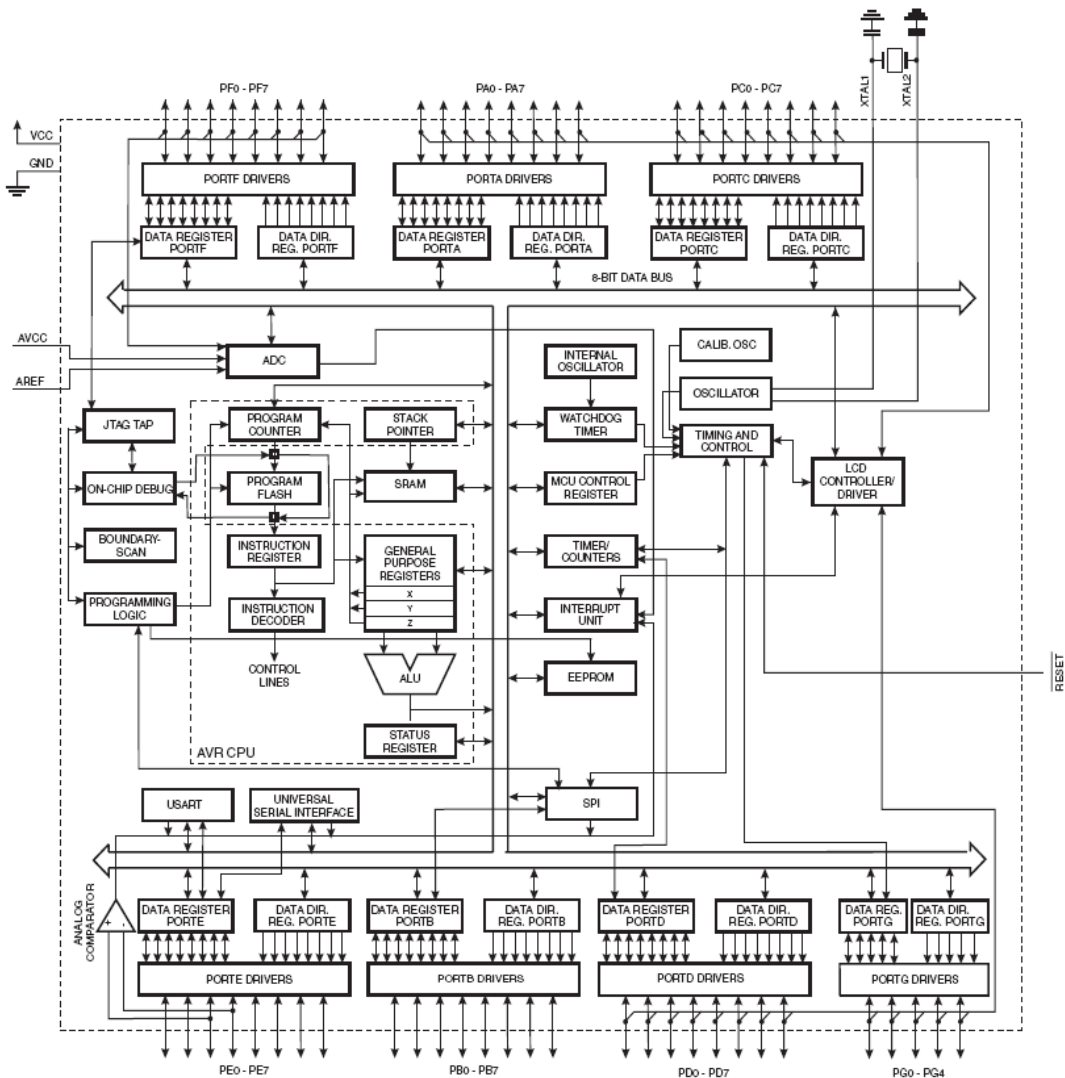

ANEXOS 3

ESQUEMA DEL CIRCUITO SIMPLIFICADO DEL ROBOT POLOLU 3PI

5.e 3pi. Esquema del circuito simplificado.

Pololu 3pi Robot Simplified Schematic Diagram

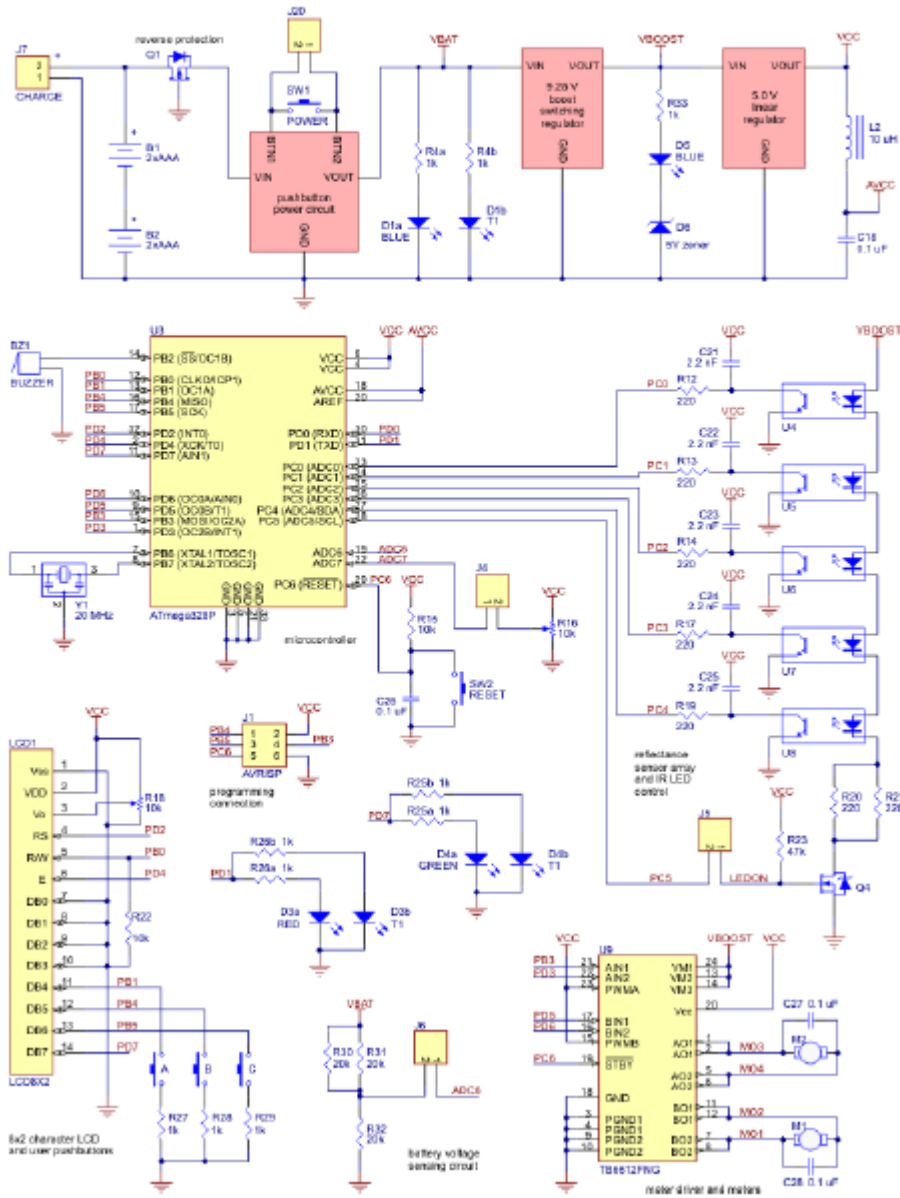

Referencias Bibliográficas

[1] Osar Gonzales , Hoja del Robot Pololu:Robotica

<http://www.pololu.com/>

Fecha de consulta 20/04/11

[2] Pololu Corporation, Guía de usuario del Robot Pololu

<http://www.pololu.com/file/0J137/Pololu3piRobotGuiaUsuario.pdf>

Fecha de Consulta 20/04/11

[3] Súper Robótica, Proyectos similares

<http://www.superrobotica.com/S320107.htm>

Fecha de Consulta 22/04/11

[4] Atmel Corporation , Hoja de Datos del microcontrolador Atmega 169

http://www.atmel.com/dyn/resources/prod_documents/doc2486.pdf

Fecha de consulta 5/04/11

[5] Atmel Corporation , Hoja de Datos del microcontrolador Atmega 328

http://www.atmel.com/dyn/products/product_card.asp?part_id=3012

Fecha de consulta 5/04/11.

[6] Atmel Corporation, AVR Butterfly, user guide

http://www.atmel.com/dyn/resources/prod_documents/doc4271.pdf

Fecha de consulta 25/ 04/11.

[7] HOPE MICROELECTRONICS CO LTD, modulo HM-TR

<http://www.roboeq.com/PDF/0501018.pdf>

Fecha de consulta 03/05/11

[8] Recursos dados para la utilización de las librerías, programadores para el

AVR butterfly así como para el pololu 3 pi,

<http://www.pololu.com/catalog/product/1227/resources>

Fecha de consulta: 20/01/11.

[9] Pardue Joe, Smiley Micros.com, C programming for Microcontrollers,

Featuring ATMEL's AVR Butterfly and the Free WinAVR Compiler, edición

2005, <http://www.smileymicros.com/>

Fecha de consulta: 10/01/11.