

Altistart 48 Panel-Mount Soft Starts

Catalog

04

File 8636



CONTENTS

Description	Page
Introduction	2-3
Technical Characteristics	4-7
Selection	8-13
Voltage References	12-13
Options	14
Powersuite® Advance Dialog Solutions	15
Dimensions	16-17
Mounting	18-19
Wiring Diagrams	20-24
Functions	25-32
Conventional Starting Curves	33-34



Altistart 48 Panel-Mount Soft Starts Introduction

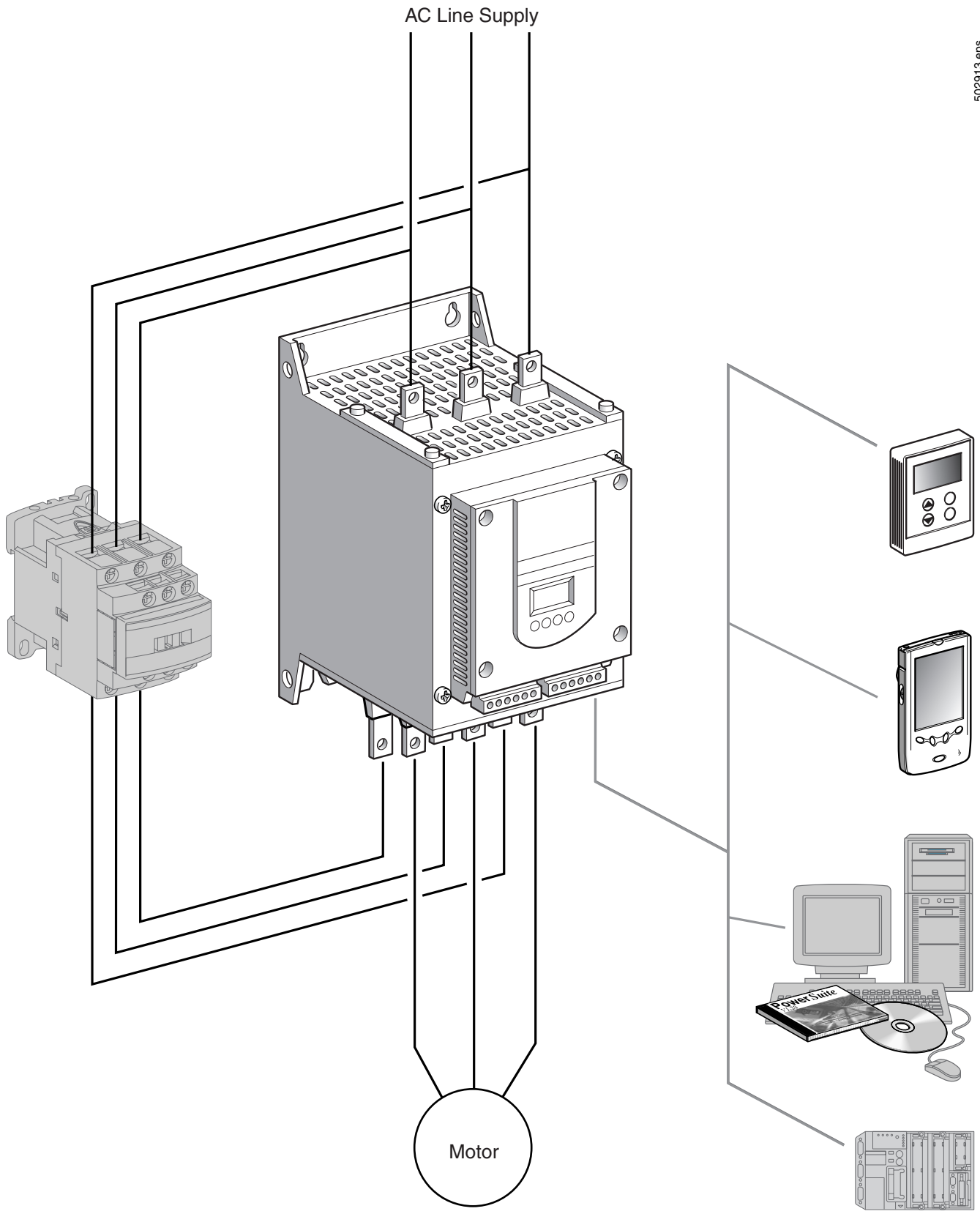

Altistart 48 Panel-Mount Soft Starts Introduction

Applications

The ATS48 soft start is a controller with 6 thyristors. It is used for torque-controlled soft starting and stopping of three-phase asynchronous squirrel cage motors with power ranges between 3 and 1200 hp.

ATS48 soft starts offer soft starting and deceleration functions, machine and motor protection functions, and functions for communicating with control systems. These functions are designed for use in state-of-the-art centrifugal machines, pumps, fans, compressors, and conveyors in the construction, food and beverage, and chemical industries. The high-performance algorithms of the ATS48 soft start contribute significantly to its robustness and ease of setup.

The ATS48 soft start is a cost-effective solution which can:

- Reduce machine operating costs by reducing mechanical stress and improving machine availability
- Reduce the stress placed on the electrical distribution system by reducing line current peaks and voltage drops during motor starts

The ATS48 soft start is rated for three-phase voltages 208 to 690 V, 50/60 Hz, and for standard and severe duty applications.

Functions

The ATS48 soft start is supplied ready for use in a standard duty application with Class 10 motor thermal overload protection. All devices include a built-in keypad display which can be used to modify the configuration to adapt it to the application and individual customer requirements.

Soft Start performance functions:

-
- | | |
|--|---|
| • Exclusive torque control system (TCS) patented by Schneider Electric | • Adjustments for ramp and the starting torque |
| • Constant control of the torque supplied to the motor during acceleration and deceleration periods (significantly reducing pressure surges) | • The soft start can be bypassed using a contactor at the end of the starting period while maintaining electronic overload protection (bypass function) |
| | • Wider frequency tolerance for generator set (source) power supplies |
-

Machine and motor protection functions:

-
- | | |
|---|--|
| • Built-in motor thermal overload protection | • Monitoring of the starting time |
| • Processing of information from PTC thermal probes | • Protection against underloads and overcurrents during continuous operation |
-

Extended I/O functions for integration into control systems:

-
- | | |
|--|--|
| • 4 logic inputs, 2 logic outputs, 3 relay outputs, and 1 analog output | • Display of electrical values, running conditions, and operating time |
| • Pull-apart terminal connectors | • RS-485 serial link for connection to a Modbus® system |
| • Function for configuring a second set of motor parameters and easy-to-adapt settings | |
-

Options

A remote keypad display can be mounted on the door of a wall-mounted or floor-standing enclosure.

PowerSuite advanced dialog solutions:

-
- | | |
|---|---|
| • PowerSuite Pocket PC with PPC type terminal. | • A range of wiring accessories for connecting the soft start to PLCs via a Modbus® Systems connection. |
| • PowerSuite software workshop. (Version 1.30, build 5 or higher) | • Ethernet, Fipio®, DeviceNet™ and Profibus® DP network communication options |
-

Characteristics: pages 4 to 7

Dimensions: pages 16 to 17

Wiring Diagrams: pages 20 to 23

Altistart 48 Panel-Mount Soft Starts

Technical Characteristics

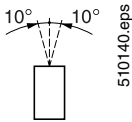
Environment		
Conformity to standards		The ATS48 soft starts have been developed and performance tested in accordance with international standards, in particular with the starter product standard EN/IEC 60947-4-2.
CE marking		CE marking in accordance with the harmonized standard EN/IEC 60947-4-2.
Product approvals		UL, CSA DNV, C-Tick, Ghost, CCIB
Pollution degree	Soft starts ATS48D17Y to 48C11Y	IP 20 (IP 00 in the absence of connections)
	Soft starts ATS48C14Y to 48M12Y (1)	IP 00
Vibration resistance	Conforming to IEC 60068-2-6	1.5 mm from 2 to 13 Hz 1 gn from 13 to 200 Hz
Shock resistance	Conforming to IEC 60068-2-27	15 g for 11 ms
Soft start noise level (2)	Soft starts ATS48D32Y to D47Y	dBA 52
	Soft starts ATS48D62Y to C11Y	dBA 58
	Soft starts ATS48C14Y to C17Y	dBA 50
	Soft starts ATS48C21Y to C32Y	dBA 54
	Soft starts ATS48C41Y to C66Y	dBA 55
	Soft starts ATS48C79Y to M12Y	dBA 60
Fans	Soft starts ATS48D17Y and D22Y	Natural convection
	Soft starts ATS48D32Y to M12Y	Forced convection. The fans are activated automatically when a temperature threshold is reached. For flow rate, see page 19.
Ambient temperature around the unit	Operation	14 to 104 °F (-10 to 40 °C) without derating Up to 140 °F (60 °C), derate the current by 2% for each °C above 40 °C (104 °F) 14 to 122 °F (-10 to 50 °C) with user supplied shorting/bypass contactor
	Storage, conforming to IEC 60947-4-2	-13 to 158 °F (- 25 to 70 °C)
Maximum relative humidity	Conforming to IEC 60068-2-3	95% without condensation or dripping water
Maximum ambient pollution	Conforming to IEC 60664-1	Level 3
Maximum operating altitude	ft (m)	3300 ft (1000 m) without derating. Above this, derate the nominal current of the soft start by 2.2% for each additional 330 ft (100 m) to a maximum of 6600 ft (2000 m).
Operating position Maximum permanent angle in relation to the normal vertical mounting position		
Electrical characteristics		
Operating category	Conforming to IEC 60947-4-2	AC-53a
Three-phase supply voltage	Soft starts ATS48***Y (3)	V 208 - 15% to 690 + 10%
Frequency		Hz 50/60 ± 5% (automatic) 50 or 60 ± 20% (must be set)
Nominal soft start current	Soft starts ATS48***Y	A 17 to 1200
SCRs	Soft starts ATS48***Y	PIV 1800
Motor power	Soft starts ATS48***Y	kW 3 to 900 HP 2 to 1200
Voltage indicated on the motor nameplate	Soft starts ATS48***Y	V 208 to 690
Soft start control circuit supply voltage	Soft starts ATS48***Y	V 110 - 15% to 230 + 10%, 50/60 Hz
Maximum control circuit consumption (with fans operating)	Soft starts ATS48D17Y to C17Y	W 30
	Soft starts ATS48C21Y to C32Y	W 50
	Soft starts ATS48C41Y to M12Y	W 80
Relay output (2 configurable outputs)	3 relay outputs (R1, R2, R3), normally open contacts 1 N.O. Minimum switching capacity: 10 mA for 6 Vdc. Maximum switching capacity on inductive load: 1.8 A for 230 Vac and 30 Vdc (power factor= 0.5 and L/R=20 ms). Maximum nominal operating voltage is 400 Vac. Factory setting: R1 assigned as the fault relay (configurable) R2 assigned as the end of starting relay to control the soft start bypass relay R3 assigned as motor powered (configurable)	
<p>(1) Protective covers can be fitted to the power terminals of ATS48C14Y to C32Y soft starts. ATS48C41Y to 48M12Y soft starts have protection on the front panel and on the sides.</p> <p>(2) Soft starts located 3 ft. (1 m) away. The noise levels may change depending on the characteristics of the fans.</p> <p>(3) Throughout this catalog, the symbol "*" designates a portion of the catalog number that varies with controller rating.</p>		
Characteristics: pages 4 to 7		Dimensions: pages 16 to 17
Wiring Diagrams: pages 20 to 23		

Altistart 48 Panel-Mount Soft Starts Technical Characteristics

Electrical characteristics (continued)		
Logic inputs LI (2 configurable inputs)	4 logic inputs: Stop, Run, LI3, LI4; Impedance: 4.3 k Ω , isolated + 24 V input (maximum 30 V) I max. 8 mA State 0 if V < 5 V State 1 if V > 11 V	
Internal source available	One 24 V output, isolated and protected against short-circuits and overloads. Accuracy \pm 25%. Max. current 200 mA.	
Logic outputs LO (configurable)	2 logic outputs LO1 and LO2 with 0 V common, compatible with level 1 PLC, according to standard IEC 65A-68. + 24 V input (minimum: +12 V, maximum: + 30 V) to LO+ Maximum LO output current: 200 mA if external 24 V power supply is used	
Analog output AO (configurable)	Current output 0-20 mA or 4-20 mA Maximum load impedance: 500 Ω Accuracy \pm 5% of the maximum value	
Input for PTC probe	Total resistance of probe circuit 750 Ω at 25 °C (77 °F), according to IEC 60 738-A	
Maximum I/O connection capacity	12 AWG (2.5 mm ²)	
Communication	RS-485 multidrop serial link integrated in the starter, for Modbus® Systems, with RJ45 type connector Transmission speed 4800, 9600 or 19200 bps Maximum number of ATS48 soft starts connected: 18 Other uses: - connection to a remote keypad display or - connection to a PC or - connection to other buses and networks via communication options.	
Protection	Thermal	Built-in, starter and motor (calculated and/or thermal protection with PTC probes)
	Line protection	Phase failure, indicated by output relay
Current settings	The nominal motor current, I _n , can be adjusted from 0.4 to 1.3 times the starter nominal current. Adjustment of the maximum starting current from 1.5 to 7 times the motor I _n , limited to 5 times the starter nominal current.	
Starting mode	By torque control with starter current limited to 5 I _n maximum. Factory setting: 4 I _n for standard operation on 15 s torque ramp	
Stopping mode	Freewheel stop	Freewheel stop (factory setting)
	Controlled stop on torque ramp	Programmable between 0.5 and 60 s (for pump applications)
	Braked stop	Controlled dynamically by the flux

Electromagnetic compatibility EMC (1)

	Standards	Test levels	Examples (sources of interference)
Summary of immunity tests carried out with the ATS48 soft start	IEC 61000-4-2 level 3 Electrostatic discharge: - by contact - in the air	6 kV 8 kV	Contact off an electrically charged individual
	IEC 61000-4-3 level 3 Radiated electromagnetic fields	10 V/m	Equipment transmitting radio frequencies
	IEC 61000-4-4 level 4 Rapid electrical transients: - power supply cables - control cables	4 kV 2 kV	Opening/closing of a contactor
	IEC 61000-4-5 level 3 Shock wave: - phase/phase - phase/ground	1 kV 2 kV	-
	IEC 61000-4-12 level 3 Damped oscillating waves	1 kV - 1 M Hz	Oscillating circuit on the line supply
Radiated and conducted emissions	According to IEC 60947-4-2, class A, on all starters According to IEC 60947-4-2, class B, on starters up to 170 A: ATS48D17● to 48C17●. Must be bypassed at the end of starting		

(1) The soft starts conform to IEC 60947-4-2 (EMC). This standard ensures a level of immunity for products and a level of emitted interference. In steady state, the interference emitted is below that required by the standard.

NOTE:

- Power factor correction capacitors can only be used upstream of the ATS48 soft start and only powered up at the end of starting.
- The soft start must be grounded to meet regulations concerning leakage currents (\leq 30 mA). If the installation involves several soft starts on the same supply line, each soft start must be grounded separately.

Characteristics: pages 4 to 7

Dimensions: pages 16 to 17

Wiring Diagrams: pages 20 to 23

Altistart 48 Panel-Mount Soft Starts

Technical Characteristics

TORQUE CHARACTERISTICS

In the following diagrams, the curves indicate changes in the torque that depend on the starting current of a three-phase asynchronous motor.

Curve 1: full voltage starting

Curve 2: starting in current limiting mode

Torque curve, T_{s1} , indicates the total torque range available depending on the limiting current I_{s1} . Limiting the starting current, I_s , to a preset value, I_{s1} , reduces the starting torque, T_{s1} , to a value which is almost equal to the square of currents I_{s1}/I_s .

Example:

For motor characteristics: $T_s = 3 T_n$ for $I_s = 6 I_n$,

limit the current to $I_{s1} = 3 I_n$ (0.5 I_s)

resulting in a starting torque $T_{s1} = T_s \times (0.5)^2 = 3 T_n \times 0.25 = 0.75 T_n$

STARTING CURRENT

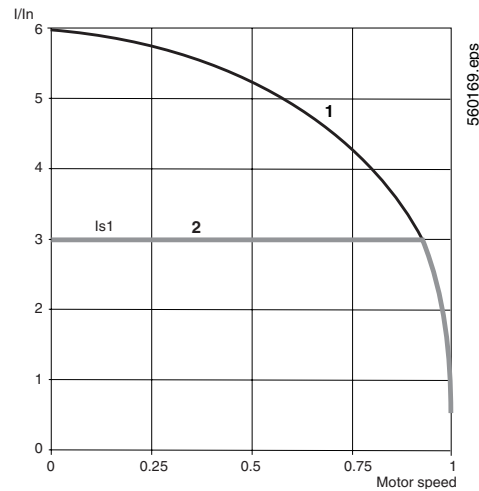

- 1) Full voltage starting current
- 2) Starting current limited to I_{s1}

STARTING TORQUE

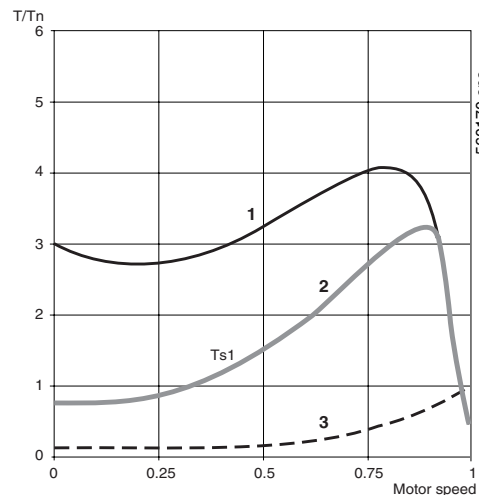

- 1) Full voltage starting torque
- 2) Starting torque with current limited to I_{s1}
- 3) Load torque

CONVENTIONAL STARTING USING CURRENT LIMITATION OR VOLTAGE RAMP

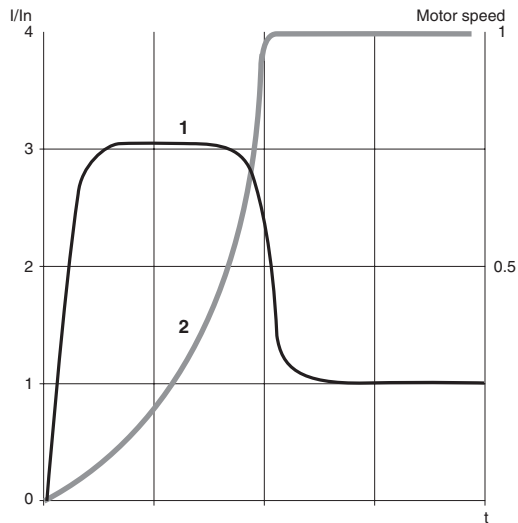

With current limitation I_{s1} , the accelerating torque applied to the motor is equal to the motor torque T_{s1} minus the resistive torque T_r . The accelerating torque increases in the starting range as the speed changes and is at its highest at the end of acceleration (curve 2). This characteristic means that the load is taken up very abruptly, which is not recommended for pump type applications.

Example of speed curve for starting with current limitation

- 1) Current applied to the motor (I/In)
- 2) Motor speed

STARTING WITH THE ATS48 SOFT START

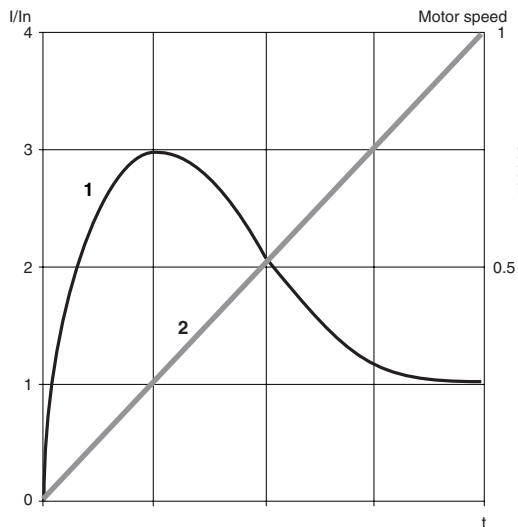

Torque control on the ATS48 soft start applies the torque to the motor during the entire starting phase if the current required (curve 1) does not exceed the limiting current. The accelerating torque can be virtually constant over the entire speed range (curve 2). It is possible to set the ATS48 soft start so as to obtain a high torque on starting for a rapid motor speed rise, while limiting its temperature rise, and a lower torque at the end of starting for gradual loading. This control function is ideal for centrifugal pumps or for machines with high resistive torque on starting.

Example of speed curve for starting with torque control

- 1) Current applied to the motor (I/In)
- 2) Motor speed

STOPPING WITH THE ATS48 SOFT START

- Freewheel stop: the motor comes to a freewheel stop.
- Decelerated stop: this type of stop is ideal for pumps. It can be used to effectively reduce pressure surges. Torque control on the ATS48 soft start reduces the effect of hydraulic transients even if the load increases. This type of control makes adjustment easy.
- Braked stop: this type of stop is suitable for high inertia applications because it reduces the stopping time of the machine.

Altistart 48 Panel-Mount Soft Starts Selection

SELECTION CRITERIA FOR AN ATS48 SOFT START UNIT

Select the ATS48 soft start on the basis of three main criteria:

1. AC Mains voltage supply:
 - Three-phase AC voltage: 208–690 V
2. The power and the nominal current (motor FLA) indicated on the motor nameplate
3. The type of application and the operating cycle

To simplify selection, the applications are categorized as 2 types:

- Standard duty applications
- Severe duty applications

Standard or severe duty applications define the limiting values of the current and the duty cycle ratings.

Standard Duty Application

In standard duty applications, the ATS48 soft start is designed to provide:

- Starting at 4x In for 23 seconds or at 3x In for 46 seconds from a cold state
- Starting at 3x In for 23 seconds or at 4x In for 12 seconds with a load factor of 50% and with 10 starts per hour or an equivalent thermal cycling

The motor thermal protection conforms to Class 10 and 20 overload protection (see page 27).

Example: Centrifugal pump

Severe Duty Application

In severe duty applications, the ATS48 soft start is designed to provide:

- Starting at 4x In for 48 seconds or at 3x In for 90 seconds from a cold state
- Starting at 4x In for 25 seconds with a load factor of 50% and with 5 starts per hour or an equivalent thermal cycling

The motor thermal protection conforms to Class 10 and 20 overload protection (see page 27).

Example: Grinder

Selecting the Soft Start

First consult page 9 to identify the application type. Once the application type has been identified, select the soft start from pages 12 to 13 according to the supply voltage and the motor power.

Caution:

If the ATS48 soft start is installed inside an enclosure, observe the mounting and derating recommendations on pages 18 and 19.

Altistart 48 Panel-Mount Soft Starts Selection

APPLICATION TYPES

Depending on the type of machine, the applications are categorized as standard or severe duty based on the starting characteristics. Examples are given in the table below.

Type of machine	Application Type	Functions performed by the ATS48 Soft Start	Starting current (% In)	Starting time (s)
Centrifugal pump	Standard	Deceleration (reduction in pressure surges) Protection against underloads or inversion of the phase rotation direction	300	5 to 15
Piston pump	Standard	Control of running dry and direction of rotation of the pump	350	5 to 10
Fan	Standard Severe if > 30 s	Detection of overloads caused by clogging or underloads (motor fan transmission broken) Braking torque on stopping	300	10 to 40
Cold compressor	Standard	Protection, even for special motors	300	5 to 10
Screw compressor	Standard	Protection against inversion of direction of phase rotation Contact for automatic draining on stopping	300	3 to 20
Centrifugal compressor	Standard Severe if > 30 s	Protection against inversion of direction of phase rotation Contact for automatic emptying on stopping	350	10 to 40
Piston compressor	Standard	Protection against inversion of direction of phase rotation Contact for automatic emptying on stopping	350	5 to 10
Conveyor, transporter	Standard	Overload control for detecting faults or underload control for detecting breaks	300	3 to 10
Lifting screw	Standard	Overload control for detecting hard spots or underload control for detecting breaks	300	3 to 10
Drag lift	Standard	Overload control for detecting jamming or underload control for detecting breaks	400	2 to 10
Lift	Standard	Overload control for detecting jamming or underload control for detecting breaks Constant starting with variable load	350	5 to 10
Circular saw, band saw	Standard Severe if > 30 s	Braking for fast stop	300	10 to 60
Pulper, butchery knife	Severe	Torque control on starting	400	3 to 10
Agitator	Standard	The current display indicates the density of the product	350	5 to 20
Mixer	Standard	The current display indicates the density of the product	350	5 to 10
Grinder	Severe	Braking to limit vibrations during stopping, overload control to detect jamming	450	5 to 60
Crusher	Severe	Braking to limit vibrations during stopping, overload control to detect jamming	400	10 to 40
Refiner	Standard	Torque control on starting and stopping	300	5 to 30
Press	Severe	Braking to increase the number of cycles	400	20 to 60

Altistart 48 Panel-Mount Soft Starts Selection

SPECIAL USES

Other criteria can influence the selection of the ATS48 soft start:

Shorting/Bypass Contactor

Refer to the recommended wiring diagrams on pages 20 to 23.

The soft start can be bypassed by a contactor at the end of starting (to limit the heat dissipated by the soft start). The shorting/bypass contactor is controlled by the soft start and the current measurements. Thermal protection remains active when the soft start is bypassed.

Multi Motors

Motors may be connected in parallel provided that the power limit of the soft start is not exceeded (the sum of the motor currents must not exceed the nominal current of the soft start selected depending on the type of application). Individual thermal protection is required for each motor.

Brush Motor

The ATS48 soft start can operate with a bypassed stator resistance motor or with a resistance lug. The starting torque is modified in accordance with the rotor resistance. If necessary, maintain a low resistance in order to obtain the required torque to overcome the resistive torque on starting.

A bypassed brush motor has a very low starting torque. A high stator current is required to obtain the sufficient starting torque.

Oversize the soft start so that the value of the limiting current is 7 times that of the nominal current.

NOTE: Ensure that the starting torque of the motor, equal to 7 times the nominal current, is greater than the resistive torque.

NOTE: The ATS48 soft start torque control enables excellent soft starting despite the limiting current being 7 times the nominal current required to start the motor.

2-Speed Motor

The ATS48 soft start can operate with a 2-speed motor. A motor demagnetization period must elapse before changing from low speed to high speed in order to avoid antiphase between the line supply and the motor, which would generate very high currents.

Select the soft start using the three main criteria, see page 8.

Long Motor Cable Lengths

Very long motor cables cause voltage drops due to the resistance of the cable. If the voltage drop is significant, it could affect the current consumption and the available torque. This criteria must be taken into account when selecting the motor and the soft start.

Miscellaneous Application Precautions

Do not use the ATS48 soft start upstream of loads other than motors (for example transformer and resistor type loads).

Do not connect power factor correction capacitors to the terminals of a motor controlled by an ATS48 soft start.

COMMUNICATION

The ATS48 soft start can be connected directly to a Modbus® system using an RJ45 connector. It communicates over the RS-485 serial link (2-wire) using the Modbus® system's RTU protocol. The communication function provides access to the configuration, adjustment, control, and signalling functions of the soft start.

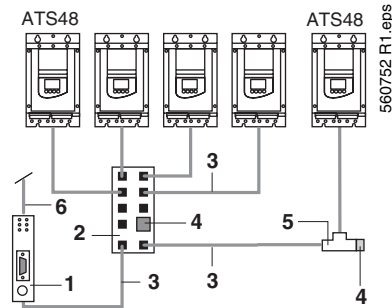

1. Communication module
2. Modbus® Systems hub **LU9GC3**
3. Modbus® Systems drop cable **VW3A8306R●●**
4. Line terminator **VW3A8306RC**
5. Modbus® Systems splitter cable **VW3A8306TF●●**
6. To other buses or networks

The ATS48 soft start can be connected to other buses or networks using the communication modules and accessories below.



Item number	Communication modules	Catalog number
1	Ethernet Bridge	174CEV30020
	DeviceNet Gateway	LUF9
	Profibus DP Gateway	LUF7
	FIPIO Gateway	LUF1
3	1/3 meter connection cable (RJ45 to RJ45)	VW3A8306R03
	1 meter connection cable (RJ45 to RJ45)	VW3A8306R10
	3 meter connection cable (RJ45 to RJ45)	VW3A8306R30
5	1/3 meter splitter cable (RJ45 daisy chain connection)	VW3A8306TF03
	1 meter splitter cable (RJ45 daisy chain connection)	VW3A8306TF10
4	RJ45 terminator (2 per package)	VW3A8306RC
2	Modbus hub (Eight RJ45 ports)	LU9GC3

Characteristics: pages 4 to 7

Dimensions: pages 16 to 17

Wiring Diagrams: pages 20 to 23

Altistart 48 Panel-Mount Soft Starts Selection

Line Voltage 208 to 690 V, Motor Power in HP

For Standard Duty Applications



ATS48D17Y

106762.tif



ATS48C14Y

106761.tif



ATS48M12Y

106758.tif

Motor				Soft Start 208 to 690 V - 50/60 Hz				
Motor power (1)				Soft start current rating (2)	Nominal motor current (4)	Power dissipated at nominal load	Catalog number	Weight
208 V	230 V	460 V	575 V	A	A	W		lb (kg)
HP	HP	HP	HP	A	A	W		lb (kg)
3	5	10	15	17	14	59	ATS48D17Y	10.8 (4.9)
5	7.5	15	20	22	21	74	ATS48D22Y	10.8 (4.9)
7.5	10	20	25	32	27	104	ATS48D32Y	10.8 (4.9)
10	—	25	30	38	34	116	ATS48D38Y	10.8 (4.9)
—	15	30	40	47	40	142	ATS48D47Y	10.8 (4.9)
15	20	40	50	62	52	201	ATS48D62Y	18.3 (8.3)
20	25	50	60	75	65	245	ATS48D75Y	18.3 (8.3)
25	30	60	75	88	77	290	ATS48D88Y	18.3 (8.3)
30	40	75	100	110	96	322	ATS48C11Y	18.3 (8.3)
40	50	100	125	140	124	391	ATS48C14Y	27.3 (12.4)
50	60	125	150	170	156	479	ATS48C17Y	27.3 (12.4)
60	75	150	200	210	180	580	ATS48C21Y	40.1 (18.2)
75	100	200	250	250	240	695	ATS48C25Y	40.1 (18.2)
100	125	250	300	320	302	902	ATS48C32Y	40.1 (18.2)
125	150	300	350	410	361	1339	ATS48C41Y	113.3 (51.4)
150	—	350	400	480	414	1386	ATS48C48Y	113.3 (51.4)
—	200	400	500	590	477	1731	ATS48C59Y	113.3 (51.4)
200	250	500	600	660	590	1958	ATS48C66Y	113.3 (51.4)
250	300	600	800	790	720	2537	ATS48C79Y	253.6 (115.0)
350	350	800	1000	1000	954	2865	ATS48M10Y	253.6 (115.0)
400	450	1000	1200	1200	1170	3497	ATS48M12Y	253.6 (115.0)

For Severe Duty Applications

Motor				Soft Start 208 to 690 V - 50/60 Hz				
Motor power (1)				Soft Start Current Rating (3)	Nominal motor current (4)	Power dissipated at nominal load	Catalog number	Weight
208 V	230 V	460 V	575 V	A	A	W		lb (kg)
HP	HP	HP	HP	A	A	W		lb (kg)
2	3	7.5	10	12	14	46	ATS48D17Y	10.8 (4.9)
3	5	10	15	17	21	59	ATS48D22Y	10.8 (4.9)
5	7.5	15	20	22	27	74	ATS48D32Y	10.8 (4.9)
7.5	10	20	25	32	34	99	ATS48D38Y	10.8 (4.9)
10	—	25	30	38	40	116	ATS48D47Y	10.8 (4.9)
—	15	30	40	47	52	153	ATS48D62Y	18.3 (8.3)
15	20	40	50	62	65	201	ATS48D75Y	18.3 (8.3)
20	25	50	60	75	77	245	ATS48D88Y	18.3 (8.3)
25	30	60	75	88	96	252	ATS48C11Y	18.3 (8.3)
30	40	75	100	110	124	306	ATS48C14Y	27.3 (12.4)
40	50	100	125	140	156	391	ATS48C17Y	27.3 (12.4)
50	60	125	150	170	180	468	ATS48C21Y	40.1 (18.2)
60	75	150	200	210	240	580	ATS48C25Y	40.1 (18.2)
75	100	200	250	250	302	695	ATS48C32Y	40.1 (18.2)
100	125	250	300	320	361	1017	ATS48C41Y	113.3 (51.4)
125	150	300	350	410	414	1172	ATS48C48Y	113.3 (51.4)
150	—	350	400	480	477	1386	ATS48C59Y	113.3 (51.4)
—	200	400	500	590	590	1731	ATS48C66Y	113.3 (51.4)
200	250	500	600	660	720	2073	ATS48C79Y	253.6 (115.0)
250	300	600	800	790	954	2225	ATS48M10Y	253.6 (115.0)
350	350	800	1000	1000	1170	2865	ATS48M12Y	253.6 (115.0)

- (1) Value indicated on the motor nameplate.
- (2) Corresponds to the soft start's continuous current rating with overload protection set to Class 10.
- (3) Corresponds to the soft start's continuous current rating with overload protection set to Class 20.
- (4) This factory setting corresponds to the value of the nominal current of a standard motor according to NEC, 460 V, Class 10 (standard application). Adjust the value of parameter In to match the motor's full load amperage rating.

Altistart 48 Panel-Mount Soft Starts Selection

Line Voltage 208 to 690 V, Motor Power in kW

For Standard Duty Applications

Motor							Soft Start 208 to 690 V - 50/60 Hz				
Motor power (1)							Soft start current rating (2)	Nominal motor current (4)	Power dissipated at nominal load	Catalog number	Weight
230 V	400 V	440 V	500 V	525 V	660 V	690 V	A	A	W		lb (kg)
kW	kW	kW	kW	kW	kW	kW					
4	7.5	7.5	9	9	11	15	17	14	59	ATS48D17Y	10.8 (4.9)
5.5	11	11	11	11	15	18.5	22	21	74	ATS48D22Y	10.8 (4.9)
7.5	15	15	18.5	18.5	22	22	32	27	104	ATS48D32Y	10.8 (4.9)
9	18.5	18.5	22	22	30	30	38	34	116	ATS48D38Y	10.8 (4.9)
11	22	22	30	30	37	37	47	40	142	ATS48D47Y	10.8 (4.9)
15	30	30	37	37	45	45	62	52	201	ATS48D62Y	18.3 (8.3)
18.5	37	37	45	45	55	55	75	65	245	ATS48D75Y	18.3 (8.3)
22	45	45	55	55	75	75	88	77	290	ATS48D88Y	18.3 (8.3)
30	55	55	75	75	90	90	110	96	322	ATS48C11Y	18.3 (8.3)
37	75	75	90	90	110	110	140	124	391	ATS48C14Y	27.3 (12.4)
45	90	90	110	110	132	160	170	156	479	ATS48C17Y	27.3 (12.4)
55	110	110	132	132	160	200	210	180	580	ATS48C21Y	40.1 (18.2)
75	132	132	160	160	220	250	250	240	695	ATS48C25Y	40.1 (18.2)
90	160	160	220	220	250	315	320	302	902	ATS48C32Y	40.1 (18.2)
110	220	220	250	250	355	400	410	361	1339	ATS48C41Y	113.3 (51.4)
132	250	250	315	315	400	500	480	414	1386	ATS48C48Y	113.3 (51.4)
160	315	355	400	400	560	560	590	477	1731	ATS48C59Y	113.3 (51.4)
-	355	400	-	-	630	630	660	590	1958	ATS48C66Y	113.3 (51.4)
220	400	500	500	500	710	710	790	720	2537	ATS48C79Y	253.6 (115.0)
250	500	630	630	630	900	900	1000	954	2865	ATS48M10Y	253.6 (115.0)
355	630	710	800	800	-	-	1200	1170	3497	ATS48M12Y	253.6 (115.0)

For Severe Duty Applications

Motor							Soft Start 208 to 690 V - 50/60 Hz				
Motor power (1)							Soft start current rating (3)	Nominal motor current (4)	Power dissipated at nominal load	Catalog number	Weight
230 V	400 V	440 V	500 V	525 V	660 V	690 V	A	A	W		lb (kg)
kW	kW	kW	kW	kW	kW	kW					
3	5.5	5.5	7.5	7.5	9	11	12	14	46	ATS48D17Y	10.8 (4.9)
4	7.5	7.5	9	9	11	15	17	21	59	ATS48D22Y	10.8 (4.9)
5.5	11	11	11	11	15	18.5	22	27	74	ATS48D32Y	10.8 (4.9)
7.5	15	15	18.5	18.5	22	22	32	34	99	ATS48D38Y	10.8 (4.9)
9	18.5	18.5	22	22	30	30	38	40	116	ATS48D47Y	10.8 (4.9)
11	22	22	30	30	37	37	47	52	153	ATS48D62Y	18.3 (8.3)
15	30	30	37	37	45	45	62	65	201	ATS48D75Y	18.3 (8.3)
18.5	37	37	45	45	55	55	75	77	245	ATS48D88Y	18.3 (8.3)
22	45	45	55	55	75	75	88	96	252	ATS48C11Y	18.3 (8.3)
30	55	55	75	75	90	90	110	124	306	ATS48C14Y	27.3 (12.4)
37	75	75	90	90	110	110	140	156	391	ATS48C17Y	27.3 (12.4)
45	90	90	110	110	132	160	170	180	468	ATS48C21Y	40.1 (18.2)
55	110	110	132	132	160	200	210	240	580	ATS48C25Y	40.1 (18.2)
75	132	132	160	160	220	250	250	302	695	ATS48C32Y	40.1 (18.2)
90	160	160	220	220	250	315	320	361	1017	ATS48C41Y	113.3 (51.4)
110	220	220	250	250	355	400	410	414	1172	ATS48C48Y	113.3 (51.4)
132	250	250	315	315	400	500	480	477	1386	ATS48C59Y	113.3 (51.4)
160	315	355	400	400	560	560	590	590	1731	ATS48C66Y	113.3 (51.4)
-	355	400	-	-	630	630	660	720	2073	ATS48C79Y	253.6 (115.0)
220	400	500	500	500	710	710	790	954	2225	ATS48M10Y	253.6 (115.0)
250	500	630	630	630	900	900	1000	1170	2865	ATS48M12Y	253.6 (115.0)

- (1) Value indicated on the motor nameplate.
- (2) Corresponds to the soft start's continuous current rating with overload protection set to Class 10.
- (3) Corresponds to the soft start's continuous current rating with overload protection set to Class 20.
- (4) This factory setting corresponds to the value of the nominal current of a standard motor according to NEC, 460 V, Class 10 (standard application). Adjust the value of parameter In to match the motor's full load amperage rating.

Characteristics: pages 4 to 7

Dimensions: pages 16 to 17

Wiring Diagrams: pages 20 to 23

Altistart 48 Panel-Mount Soft Starts

Remote Keypad Display and Protective Covers

REMOTE KEYPAD DISPLAY

The remote keypad display can be mounted on the door of a wall-mounted or floor-standing enclosure. It has the same signalling display and configuration buttons as the keypad display integrated in the soft start. A switch to lock access to the menus is located on the back of the keypad display.

The option includes:

- The remote keypad display
- A mounting kit containing a cover, screws and an IP 65 seal on the front panel
- A 9.82 ft. (3 m) connecting cable with a 9-pin SUB-D connector for connecting to the keypad display and an RJ45 connector for connecting to the ATS48 soft start.



VW3G48101

106770.tif

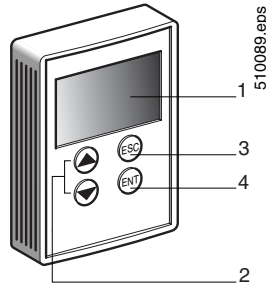

510089.eps

1. Information is displayed in the form of codes or values in three 7-segment displays
2. Buttons for scrolling through the menus or modifying values
3. ESC: Button for exiting the menu (cannot be used for validation purposes)
4. ENT: Validation button for entering a menu or confirming the new value selected

Description	Catalog number	Weight lb (kg)
Remote keypad display	VW3G48101	0.44 (0.20)

PROTECTIVE COVERS FOR POWER TERMINALS

To be used with tags closed

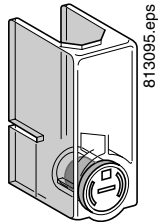

LA9F702

813095.eps

For Soft Starts	Number of covers per set	Catalog number	Weight lb (kg)
ATS48C14Y and ATS48C17Y	6 (1)	LA9F702	0.6 (0.25)
ATS48C21Y, ATS48C25Y and ATS48C32Y	6 (1)	LA9F703	0.6 (0.25)

(1) The soft starts have 9 unprotected power terminals.

Altistart 48 Panel-Mount Soft Starts Powersuite® Advanced Dialog Solutions

The PowerSuite advanced dialog solutions can be used for Telemecanique drives and soft starts. They enable communication with the product from a Pocket PC, Personal Computer, or a dedicated terminal. The PowerSuite dialog solutions, with a Pocket PC or PC, enable files to be prepared for uploading to the drives and the soft starts. The PowerSuite software creates its files ensuring consistency between the configuration/adjustment functions of the product.

PowerSuite Pocket PC

The Pocket PC can be used during preparation, programming, setup and maintenance. It comprises a Pocket PC terminal and corresponding connection accessories. The software is integrated into a Windows CE environment. The software incorporates all the functions of integrated and remote terminals (drive or soft start configuration and adjustment, control, signalling, etc).

The Pocket PC can be used:

- Alone to prepare and store configuration/adjustment files (integral battery or line supply).
- Connected to the drive or to the soft start for configuration, adjustment or control purposes or to upload a configuration/adjustment file from the Pocket PC to the product or download a configuration/adjustment file from the product to the Pocket PC.

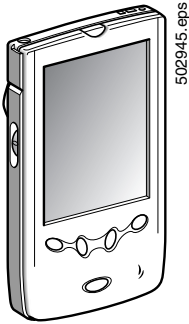

502945.eps

PowerSuite Software for PC

The PowerSuite software is used to set up a drive or a soft start from a PC in a Microsoft® Windows environment. The software incorporates all the functions of integrated and remote terminals (drive or soft start configuration and adjustment, control, signalling, etc.) in a Windows environment. It can be used:

- Alone to prepare and store drive or soft start configuration files. The drive or soft start configuration can be printed out on paper or can be exported to office automation software.
- Connected to the drive or soft start for configuration, adjustment or control purposes, or for uploading a configuration/adjustment file from the PC to the product or downloading from the product to the PC. Connection is via a link between the drive or soft start connector and the serial port on the PC.



510086.eps

POWERSUITE Products Available from Schneider Electric

Catalog number	Description
VW3A8104	POWERSUITE commissioning software on CD
VW3A8106	PC connection kit. Includes the following to connect a PC to an ATV11, ATV28, ATV58, ATS48, or TeSys U controller: 1 m (3.28 ft.) cable with RJ45 connectors RJ45 to DB9 male adapter for use with an ATV58 controller RS-232 to RS-485 adapter with RJ45 and DB9 female connectors Cable adapter for use with an ATV11 controller, VW3A11301
VW3A8110	Optional compact flash memory module loaded with POWERSUITE software, for use with JORNADA and iPAQ PPCs
VW3A8111	Pocket PC connection kit. Includes the following to connect a JORNADA or iPAQ PPC to an ATV11, ATV28, ATV58, ATS48, or TeSys U controller: 0.5 m (1.64 ft.) cable with RJ45 connectors RJ45 to DB9 male adapter for use with an ATV58 controller RS-232 to RS-485 adapter with RJ45 and DB9 male connectors Cable adapter for use with an ATV11 controller, VW3A11301
VW3A11301	RS-485 to TTL cable adapter for use with the ATV11 controller

For more information about PowerSuite software, obtain Data Bulletin 8806DB0001R_ available at www.us.SquareD.com.

Magelis® Display Unit With Matrix Screen

The Magelis® display unit with matrix screen can be used to monitor, diagnose, and adjust up to 8 ATS48 soft starts in 5 languages (English, French, German, Spanish, Italian). It can display variables in alphanumeric format with European, Cyrillic, or Asian fonts in 4 sizes, or it can display icons or background images in black and white, as well as animations in barchart or gauge format. The terminal has a backlit LCD with 8 lines of 40 characters.

Description	Catalog number	Weight lb (kg)
Magelis® display unit with matrix screen	XBTHM017010A8	1.3 (0.60)

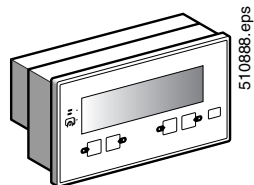

510888.eps

Altistart 48 Panel-Mount Soft Starts

Dimensions

ATS48D17Y to ATS48D47Y

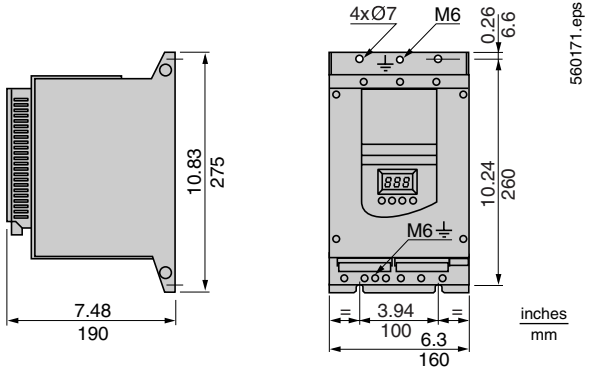

Maximum connection capacity:
 Ground connections: 8 AWG (10 mm²)
 Power terminals: 8 AWG (16 mm²)

ATS48D62Y to ATS48C11Y

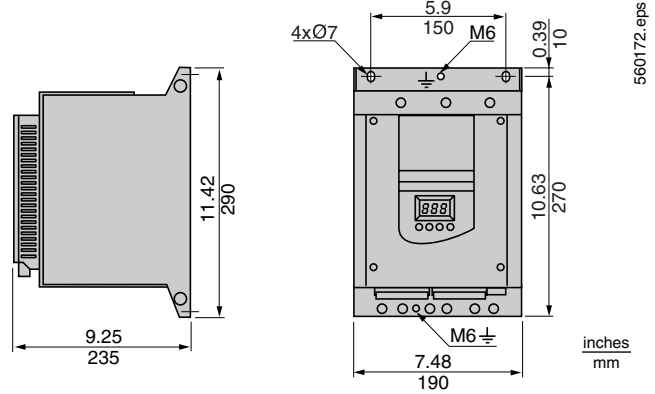

Maximum connection capacity:
 Ground connections: 4 AWG (16 mm²)
 Power terminals: 2/0 (50 mm²)

ATS48C14Y to ATS48C17Y

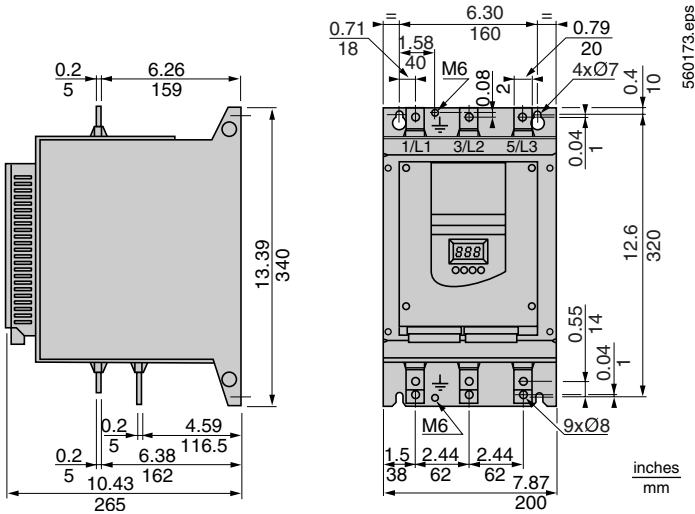

Maximum connection capacity:
 Ground connections: Busbar (120 mm²)
 Power terminals: 2/0 (95 mm²)

ATS48C21Y to ATS48C32Y

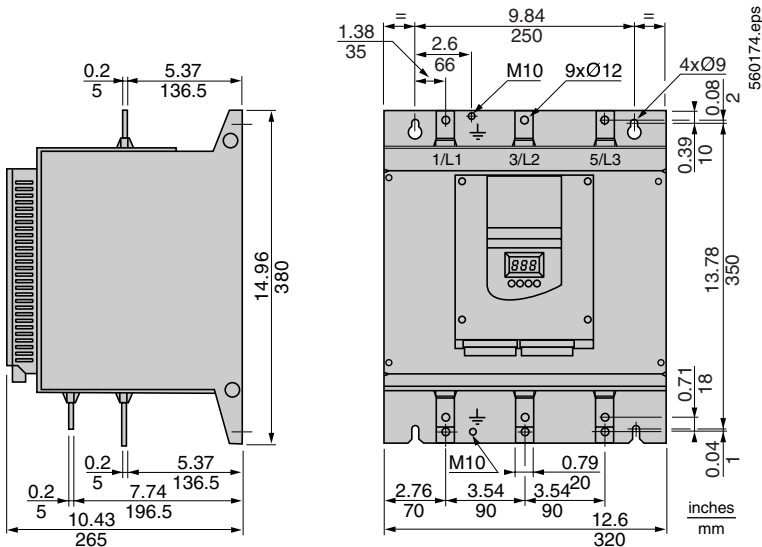

Maximum connection capacity:
 Ground connections: Busbar (120 mm²)
 Power terminals: Busbar (240 mm²)

Altistart 48 Panel-Mount Soft Starts Dimensions

ATS48C41Y to C66Y

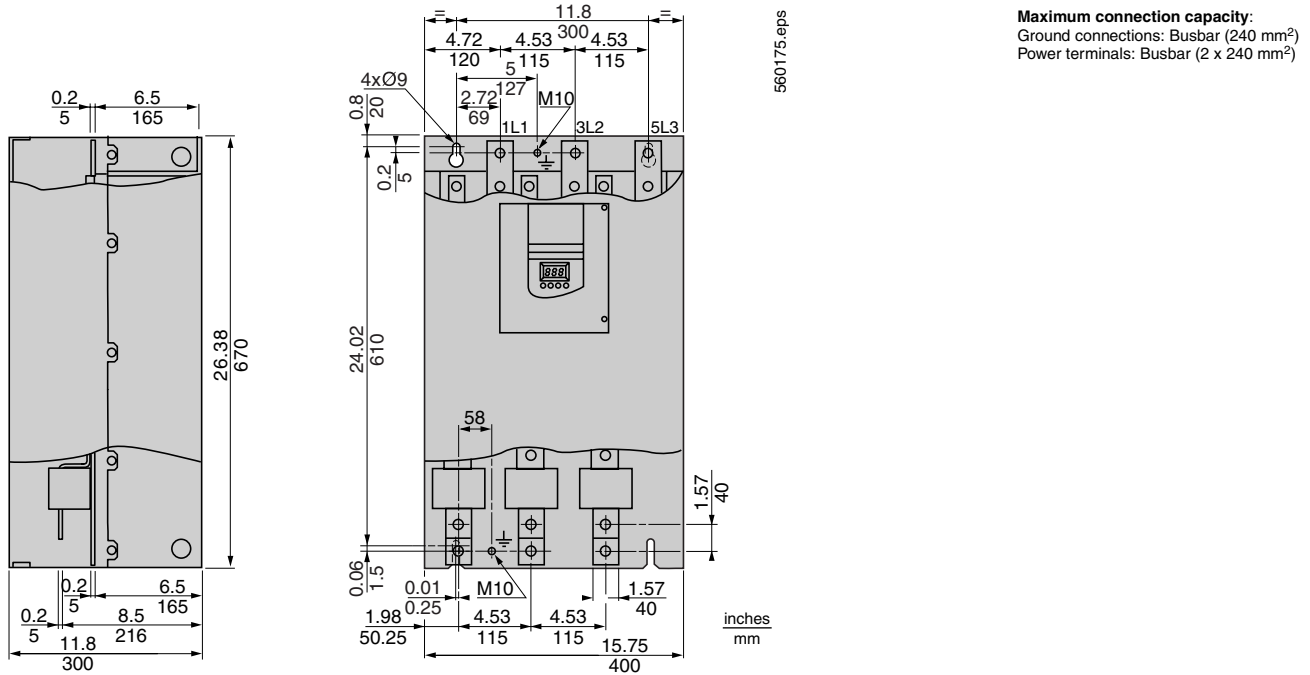

ATS48C79Y to M12Y

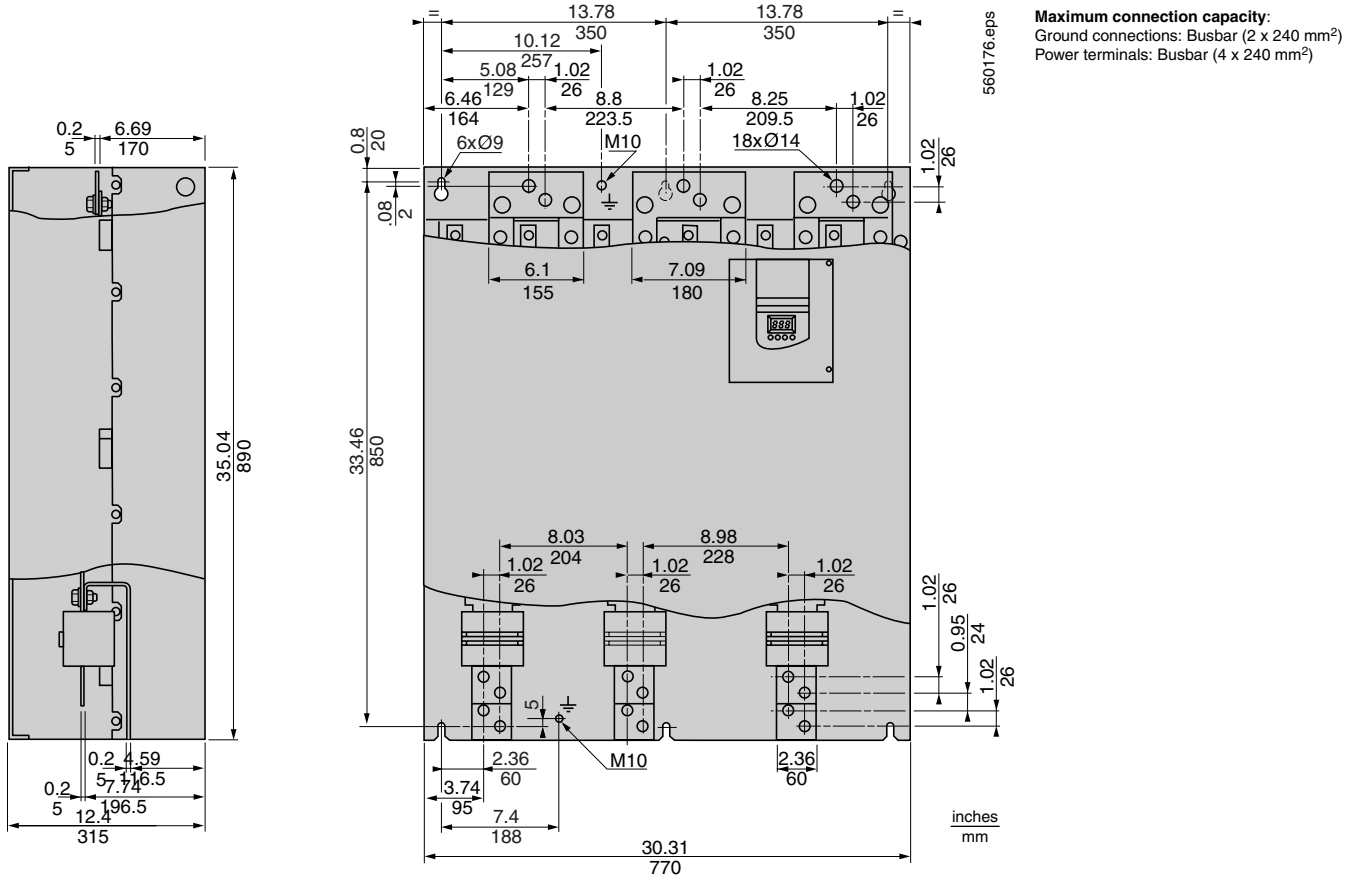

Characteristics: pages 4 to 7

Dimensions: pages 16 to 17

Wiring Diagrams: pages 20 to 23

Altistart 48 Panel-Mount Soft Starts Mounting

MOUNTING THE REMOTE KEYPAD DISPLAY

VW3G48101

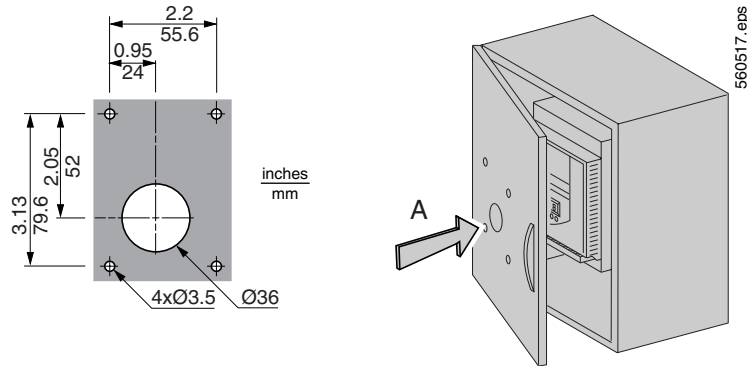

MOUNTING RECOMMENDATIONS

- Install the ATS48 soft start vertically, within $\pm 10^\circ$.
- Do not place the ATS48 soft start near sources of heat.
- Leave sufficient free space to ensure that the air required for cooling can circulate from the bottom to the top of the unit.

NOTE: The IP 00 version of the ATS48 soft start must be fitted with a protective cover to protect personnel against electrical contact. Protective covers are available for the ATS48C14Y to ATS48C32Y. They should be ordered separately. See page 14.

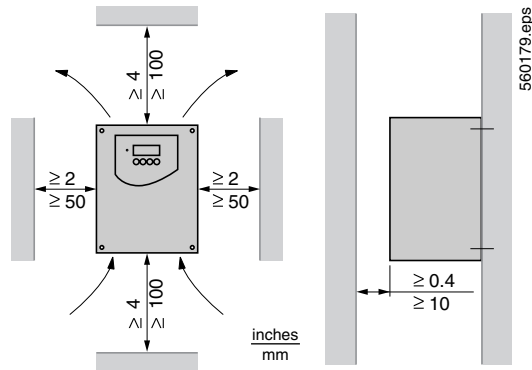

Altistart 48 Panel-Mount Soft Starts Mounting

MOUNTING IN A METAL WALL-MOUNTED OR FLOOR-STANDING ENCLOSURE WITH DEGREE OF PROTECTION TYPE 1 (IP 23) OR TYPE 12 (IP 54)

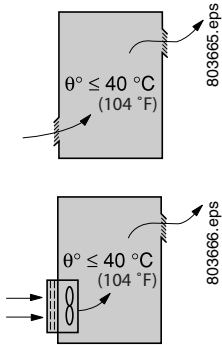

- Observe the mounting recommendations on page 18.
- To ensure proper air circulation in the soft start:
 - Fit ventilation grilles
 - Ensure that there is sufficient ventilation. If not, install forced ventilation with a filter. The openings and/or fans must provide a flow rate at least equal to that of the soft start fans (see the table below)
- Use special filters with Type 12 (IP 54) protection.

Fan Flow Rate Depending On The Soft Start Rating

ATS48 Soft Start	Flow rate CFM	Flow rate m ³ /hour
ATS48D32Y and D38Y	24	14
ATS48D47Y	48	28
ATS48D62Y to C11Y	146	86
ATS48C14Y and C17Y	235	138
ATS48C21Y to C32Y	476	280
ATS48C41Y to C66Y	1020	600
ATS48C29Y to M12Y	2040	1200

For non-ventilated ATS48 soft starts (ATS48D17Y and 48D22Y) in metal wall-mounted or floor-standing enclosures with Type 12 (IP 54) degree of protection, install no more than 2" (50 mm) below the soft start to circulate the air inside the enclosure in order to avoid hot spots.

Calculating Enclosure Size

The maximum allowable thermal resistance of the enclosure, R_{th} (°C/W), is calculated as follows:

$$R_{th} = \frac{\theta - \theta_e}{P}$$

θ = maximum temperature inside enclosure in °C
 θ_e = maximum external temperature in °C
 P = total power dissipated in the enclosure in W

- The soft start/motor combinations on pages 12 and 13 can be used in ambient temperatures ≤ 40 °C (104 °F).
- For temperatures between 40 °C and 60 °C (104 °F and 140 °F), derate the maximum permanent current of the soft start by 2% for every degree above 40 °C (104 °F).
- For the power dissipated by the soft starts at rated load: see pages 12 and 13.
- If the starts are infrequent, use a shorting/bypass contactor with the ATS48 soft start at the end of starting to minimize heat dissipation.

Calculate minimum useful heat exchange surface area requirement, S (in²):

$$S = \frac{K}{R_{th}}$$

R_{th} = thermal resistance of the enclosure (calculated previously)
 K = thermal resistance per square inch of the enclosure
 K = 186 with enclosure fan
 K = 233 without enclosure fan

Compare the effective heat exchange surface area to the proposed wall mounted enclosure, S (in²) which should be less than:

$$S = (\text{Front area}) + (\text{Top area}) + 2 (\text{Side area})$$

Characteristics: pages 4 to 7

Dimensions: pages 16 to 17

Wiring Diagrams: pages 20 to 23

Altistart 48 Panel-Mount Soft Starts Recommended Wiring Diagrams

Nonreversing with Shunt Trip Fault Isolation

wiring 2B final.eps

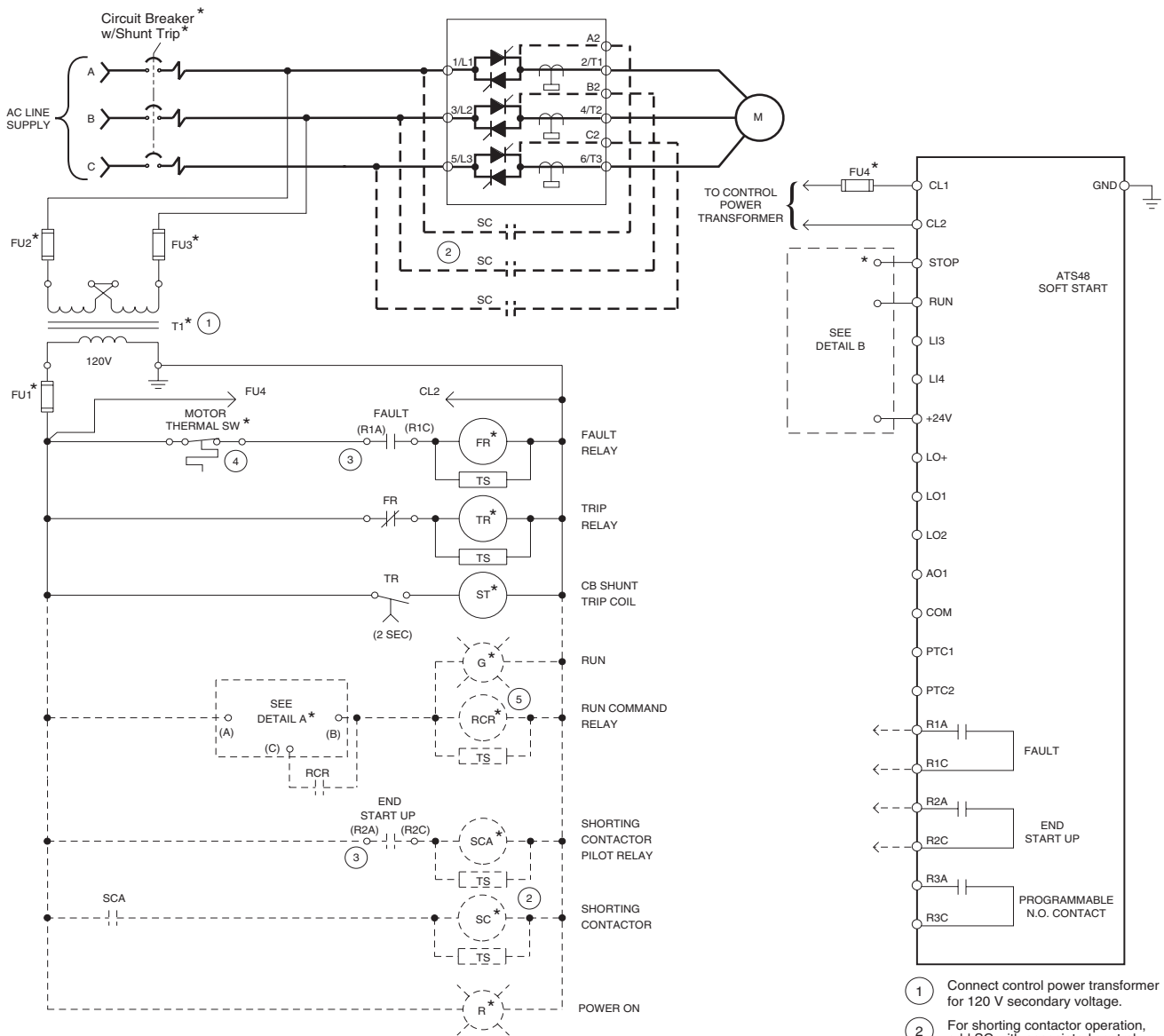

- ① Connect control power transformer for 120 V secondary voltage.
- ② For shorting contactor operation, add SC with associated control circuit.
- ③ Relay contact located on ATS48 controller.
- ④ Located at motor. Jumper if switch not present.
- ⑤ Use RCR relay logic for 120 V control of the ATS48. For 24 Vdc control, omit the RCR relay logic and wire controls directly to the ATS48 (see DETAIL B).

* = User supplied

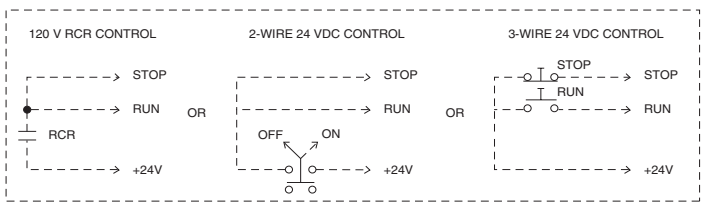
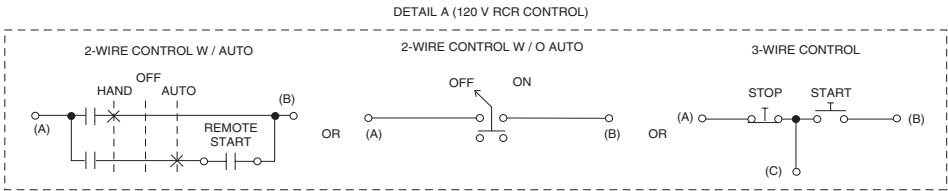

Altistart 48 Panel-Mount Soft Starts Recommended Wiring Diagrams

Nonreversing with Isolation Contactor

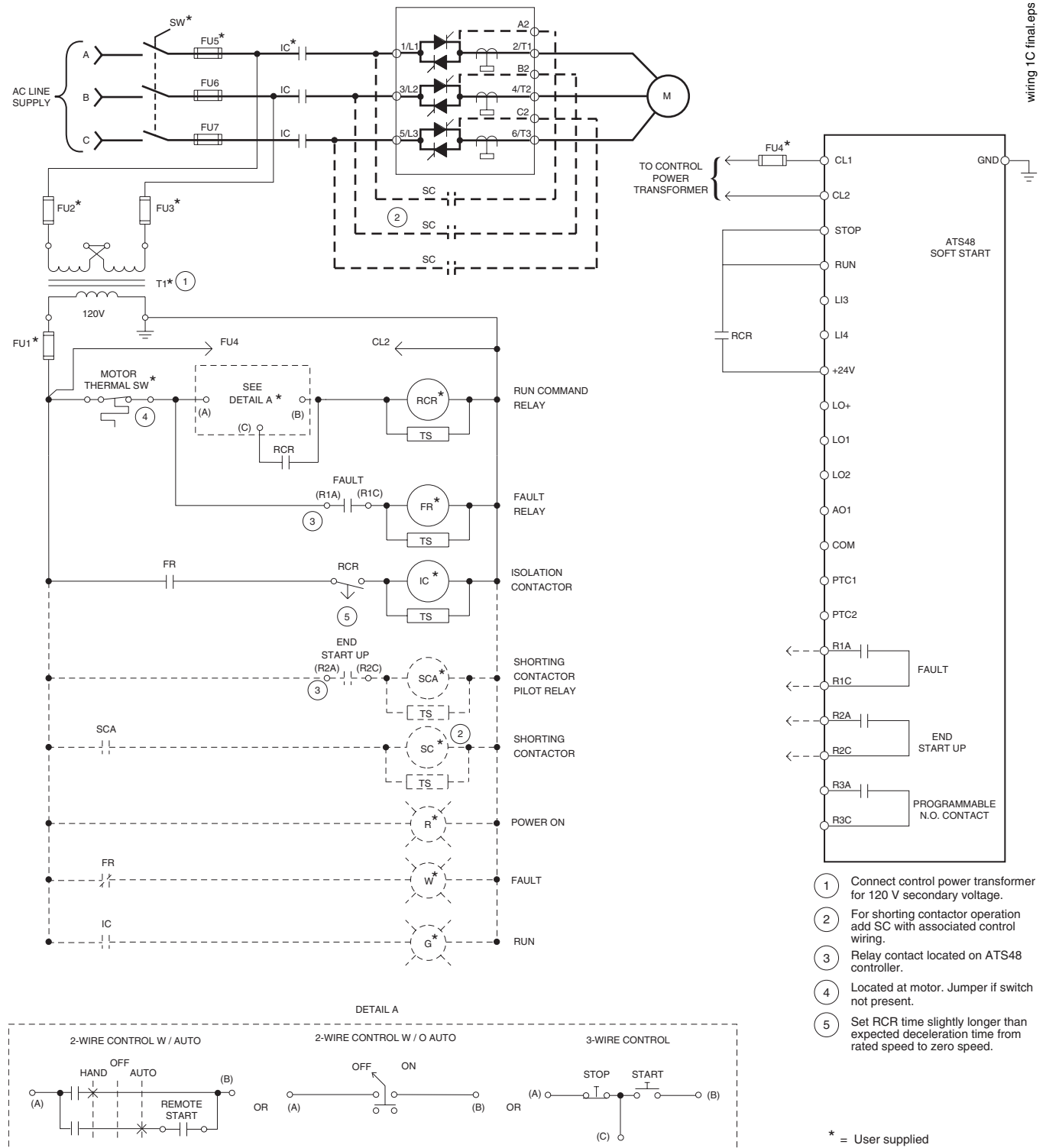

- 1 Connect control power transformer for 120 V secondary voltage.
- 2 For shorting contactor operation add SC with associated control wiring.
- 3 Relay contact located on ATS48 controller.
- 4 Located at motor. Jumper if switch not present.
- 5 Set RCR time slightly longer than expected deceleration time from rated speed to zero speed.

Characteristics: pages 4 to 7

Dimensions: pages 16 to 17

Wiring Diagrams: pages 20 to 23

Altistart 48 Panel-Mount Soft Starts Recommended Wiring Diagrams

Reversing with Isolation Contactors

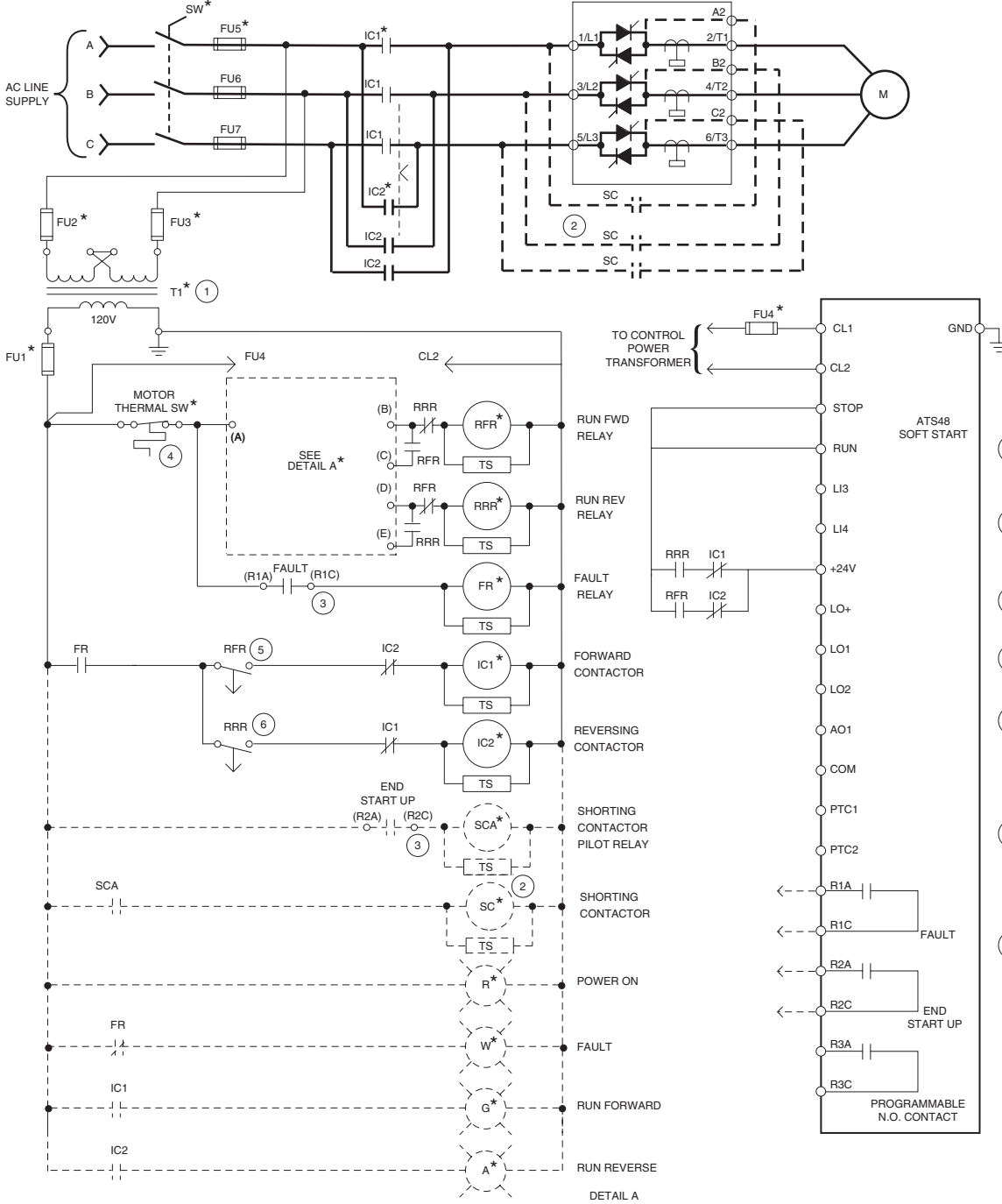

wiring 3C final.eps

- 1 Connect control power transformer for 120 V secondary voltage.
 - 2 For shorting contactor operation, add SC with associated circuitry.
 - 3 Relay contact located on ATS48 controller.
 - 4 Located at motor. Jumper if switch not present.
 - 5 Set RFR time slightly longer than the expected deceleration time from rated forward speed to zero speed.
 - 6 Set RRR time slightly longer than the expected deceleration time from rated reverse speed to zero speed.
 - 7 Remove these contacts to inhibit direction reversal without first depressing STOP push button.
- * = User supplied

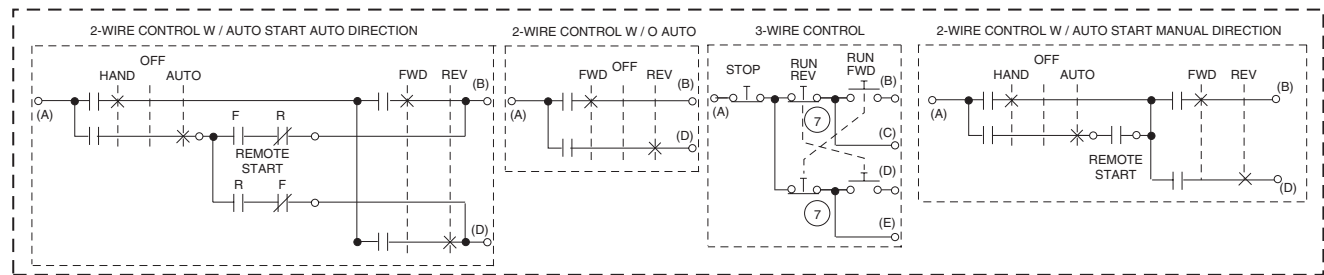

Altistart 48 Panel-Mount Soft Starts Recommended Component Lists

Description of Logic for Recommended Wiring Diagrams

Item	Name	Description
IC1 IC1A	Isolation Contactor (Fwd)	The isolation contactor logic closes IC1 upon a start command and opens IC1 after the stop is complete. The RCR (or RFR and RRR for reversing) are timed contacts that must have a time delay greater than the deceleration ramp time or the braking time. When a coast stop is selected, the time delay must be set for a time that will allow a complete decay of the motor residual voltage. The isolation contactor will open immediately upon a fault. The pilot relay (IC1A) is required when the IC1 contactor coil exceeds the ATS48 relay output ratings.
IC2 IC2A	Isolation Contactor (Rev)	Used for reversing applications only, the IC2 must be mechanically interlocked to IC1. A reversing contactor may be used for the combination of IC1 and IC2. In general, the operation of IC2 is identical to IC1. The pilot relay (IC1A) is required when the IC1 contactor coil exceeds the ATS48 relay output ratings.
SC SCA	Shorting Contactor & Pilot Relay	The shorting contactor is used to reduce the heat dissipated by the soft start when the motor is operating at full speed and voltage. The soft start provides proper sequencing of this contactor by the "end-start-up" relay. When the start is completed, the shorting contactor will be commanded to close. The soft start will continue to monitor the motor thermal state and provide motor overload protection. Upon a stop command, the SC contactor will open, transferring the motor current to the ATS48 soft start to allow for controlled deceleration if desired. The pilot relay (SCA) is required when the SC contactor coil exceeds the ATS48 relay output ratings.
TS	Transient Suppressors	Transient suppression of all relay and contactor coils (except ST) is recommended to minimize the possibility of electrical interference with the soft start electronics and to increase relay contact life.
RCR	Run Command Relay	Used in shunt trip isolation installations only if 120 V control of the ATS48 soft start is required. Used in non-reversing installations with a isolation contactor for proper sequencing of contactor logic. When energized, RCR initiates the start sequence. When de-energized, stopping is initiated. Operator controls can be either on/off selector switch, HOA selector switch or start/stop push buttons. RCR remains energized during a fault. Once the fault condition has been cleared, RCR must be de-energized by a "stop" command then re-energized to restart the soft start.
RFR	Run Forward Relay	Used for reversing applications only, this coil duplicates the functionality of RCR for the forward direction and is interlocked with the RFR relay.
RRR	Run Reverse Relay	Used for reversing applications only, this coil duplicates the functionality of RCR for the reverse direction and is interlocked with the RRR relay.
ST	Shunt Trip Coil	This coil is attached to the shunt trip coil on the disconnect and will energize 2 seconds after a soft start fault by the TR timer contact. The time delay is to prevent nuisance tripping of the circuit breaker during soft start power-up or during line undervoltage conditions.
TR	Trip Relay	Used in shunt trip circuit breaker logic only; coil energized upon a soft start fault.
FR	Fault Relay	The fault relay is energized during normal operation and deenergizes if the soft start fault contacts open or if the motor thermal switch (if supplied) opens. FR also provides additional contacts for the soft start fault output.

Suggested Components for Standard Duty Applications

Induction Motor				ATS48 Soft Start		FU4	
Rated hp ⁽¹⁾				ATS48 Soft Start	Device Rated Current	ATS Control	Class CC 600 V Time Delay
208 V	230 V	460 V	575 V	Model	@ 40 °C (104 °F) ⁽²⁾	Power Burden (W)	@ 115 V
3	5	10	15	ATS48D17Y	17	25	0.5 A
5	7.5	15	20	ATS48D22Y	22	25	0.5 A
7.5	10	20	25	ATS48D32Y	32	30	0.6 A
10	—	25	30	ATS48D38Y	38	30	0.6 A
—	15	30	40	ATS48D47Y	47	30	0.6 A
15	20	40	50	ATS48D62Y	62	30	0.6 A
20	25	50	60	ATS48D75Y	75	30	0.6 A
25	30	60	75	ATS48D88Y	88	30	0.6 A
30	40	75	100	ATS48C11Y	110	30	0.6 A
40	50	100	125	ATS48C14Y	145	30	0.6 A
50	60	125	150	ATS48C17Y	170	30	0.6 A
60	75	150	200	ATS48C21Y	210	50	1 A
75	100	200	250	ATS48C25Y	250	50	1 A
100	125	250	300	ATS48C32Y	320	50	1 A
125	150	300	350	ATS48C41Y	410	80	1.5 A
150	—	350	400	ATS48C48Y	480	80	1.5 A
—	200	400	500	ATS48C59Y	590	80	1.5 A
200	250	500	600	ATS48C66Y	660	80	1.5 A
250	300	600	800	ATS48C79Y	790	80	1.5 A
350	350	800	1000	ATS48M10Y	1000	80	1.5 A
400	450	1000	1200	ATS48M12Y	1200	80	1.5 A

(1) Motor full load currents through 500 hp @ 460/575 V, 250 hp @ 230 V, and 200 hp @ 208 V are taken from the National Electric Code (NFPA 70-2002, Table 430.150). Above these ratings, motor full load currents are calculated based upon 1.2 A/hp for 460 V and 2.4 A/hp for 230 V. Motors listed are for standard duty applications. For severe duty applications, select the next larger soft start size.

(2) The ambient temperature indicated in the table represents the temperature of the air surrounding the ATS48 soft start. Any additional temperature factors associated with the enclosure system or actual installation ambient temperature must be considered when determining the actual rated current (I_{CL}) of the soft start. For operating ambient above 40 °C (104 °F) without a shorting/bypass contactor and 50 °C (122 °F) with a shorting/bypass contactor but not exceeding 60 °C (140 °F), the rated current (I_{CL}) of the soft start must be de-rated by 2% per °C.

NOTE: To select control operators (push buttons, pilot lamps, and selector switches), control power transformers, and wire management devices (control and power terminal strips, wire terminations) indicated on the recommended wiring diagram configurations, visit www.us.squared.com.

Altistart 48 Panel-Mount Soft Starts

Recommended Component Lists

Additional Suggested Components for Standard Duty Applications

ATS48 Soft Start	Contactors ^{(1), (2), (3)}				Disconnect ⁽⁴⁾			
ATS48 Model	IC1	IC2	SC	Fusible Disconnect			Circuit Breaker	
	Isolation Contactor	Reversing Contactor ⁽⁵⁾	Mechanical Interlock	Shorting Contactor (AC1)	Power Fuses Class/Rating	Fuse Block ⁽⁶⁾	Molded Case Switch ⁽⁷⁾	Thermal Magnetic ⁽⁷⁾
D17Y	LC1D09	LC1D09	(8)	LC1D09	J / 25	60308J	FHL36000M	FAL36030
D22Y	LC1D18	LC1D18	(8)	LC1D18	J / 30	60308J	FHL36000M	FAL36040
D32Y	LC1D25	LC1D25	(8)	LC1D25	J / 40	60608J	FHL36000M	FAL36050
D38Y	LC1D32	LC1D32	(8)	LC1D32	J / 50	60608J	FHL36000M	FAL36060
D47Y	LC1D40	LC1D40	(8)	LC1D40	J / 60	60608J	FHL36000M	FAL36080
D62Y	LC1D50	LC1D50	(8)	LC1D50	J / 80	61038J	FHL36000M	FAL36090
D75Y	LC1D80	LC1D80	(8)	LC1D80	J / 100	61038J	FHL36000M	FAL36100
D88Y	LC1D80	LC1D80	(8)	LC1D80	J / 120	62003J	KHL36000M	KAL36110
C11Y	LC1D115	LC1D115	(8)	LC1D115	J / 150	62003J	KHL36000M	KAL36150
C14Y	LC1D115	LC1D115	(8)	LC1D115	J / 200	62003J	KHL36000M	KAL36200
C17Y	LC1F150	LC1F150	LA9FF970	LC1F150	J / 225	64033J	LHL36000M	LAL36225
C21Y	LC1F185	LC1F185	LA9FG970	LC1F185	J / 300	64033J	LHL36000M	LAL36250
C25Y	LC1F225	LC1F225	LA9FJ970	LC1F225	J / 350	64033J	LHL36000M	LAL36350
C32Y	LC1F330	LC1F330	LA9FJ970	LC1F330	J / 400	64033J	LHL36000M	LAL36400
C41Y	LC1F400	LC1F400	LA9FJ970	LC1F400	J / 500	6633J	MHL36000M	MAL36500
C48Y	LC1F500	LC1F500	LA9FJ970	LC1F500	J / 600	6633J	MHL360006M	MAL36600
C59Y	LC1F500	LC1F500	LA9FJ970	LC1F500	L / 700	(6)	MHL360008M	MAL36800
C66Y	LC1F630	LC1F630	LA9FJ970	LC1F630	L / 900	(6)	MHL360008M	MAL36900
C79Y	LC1F630	LC1F630	LA9FL970	LC1F630	L / 1100	(6)	MHL36000M	(9)
M10Y	LC1F780	LC1F780	LA9FL970	LC1F780	L / 1350	(6)	MHL36000M	(9)
M12Y	LC1F780	LC1F780	LA9FX970	LC1F780	L / 1600	(6)	NCL3600012M	(9)

- (1) All coils are selected for 120 V, 60 Hz operation. Refer to the *Digest* for additional coil voltages or auxiliary contact configurations. One block may be added to each contactor.
- (2) Power terminals are not included with LC1-F contactors. For additional ordering information visit www.us.SquareD.com.
- (3) The use of transient suppressors across all contactor coils is recommended. Refer to the latest editions of Schneider Electric's full line product catalogs for selection of transient suppressors.
- (4) According to the National Electric Code, branch circuit overcurrent protection must be provided for each soft start. Short circuit protective devices recommended in this table are within NEC requirements for Type 1 coordination.
- (5) Reversing contactors for C11 through M12 soft starts must be assembled from components. Parts quantities for a basic contactor assembly, minus the power connection links and terminals, are indicated before each part number. Refer to the latest editions of Schneider Electric's full line product catalogs for power connector link and terminal kits. Reversing contactor interlock units used for the C79 through M12 soft starts are designed for vertical interlocking of the individual contactors. Horizontally interlocked contactors are used for D17 through C59 soft starts.
- (6) Fuse holder part number references are for Class J fuses only based on Ferraz Shawmut spring reinforced with box type connectors acceptable for Al/Cu wiring. Class L fuses require bolt-on connections to user-supplied power bus work.
- (7) The molded case switches and circuit breakers selected require the addition of operator mechanisms to allow operation from the exterior of an enclosure. Refer to the latest editions of Schneider Electric's full line product catalogs for operator mechanism information. When using a shunt trip relay for SCR fault isolation, order a disconnect switch with suffix -1021 for addition of shunt trip coil.
- (8) The D Line contactor is available as a reversing configuration. For these applications, change the IC1 part number prefix from LC1- to LC2- to order the IC1 and IC2 combination complete with mechanical interlocks.
- (9) Devices rated above 660 A have not been coordinated with circuit breakers. You must use a Class L fuse for overcurrent protection with ATS48 soft start models C79, M10, and M12.

Altistart 48 Panel-Mount Soft Starts Functions

Summary of Functions

Description	See pages	
Soft Start factory setting	p. 25	
Adjustment functions	Nominal motor current (maximum permanent current)	p. 26
	Limiting current	p. 26
	Acceleration ramp time	p. 26
	Initial starting torque	p. 26
	Selection of the type of stop	p. 26
Protection functions	Calculated motor thermal protection	p. 27
	Reset motor thermal state	p. 27
	Motor thermal protection with PTC probes	p. 27
	Soft start thermal protection	p. 27
	Motor underload protection	p. 28
	Excessive acceleration time protection	p. 28
	Current overload protection	p. 28
	Protection against line phase inversion	p. 28
	Time before restarting	p. 28
	Motor phase loss detection	p. 28
Automatic restart	p. 28	
Advanced adjustment functions	Torque limit	p. 29
	Voltage boost level	p. 29
	Test on low power motor	p. 29
	Activation of the cascade function	p. 29
	Line frequency	p. 29
	Reset kWh or the operating time	p. 29
Return to factory settings	p. 29	
2nd motor adjustment functions	p. 29	
Communication functions	p. 30	
PowerSuite advanced dialog solutions	p. 30	
Application monitoring functions	p. 30	
Logic input application functions	2-wire/3-wire control	p. 31
	Freewheel stop	p. 31
	External fault	p. 31
	Forced to local control mode	p. 31
	Reset motor thermal fault	p. 31
	Activation of the cascade function	p. 31
	Reset all faults	p. 31
Logic output application functions	p. 32	
Relay and analog output application functions	p. 32	
Function compatibility table	p. 32	

Soft Start Factory Setting

The soft start is supplied ready for use in most applications. The default settings of the primary functions are as follows:

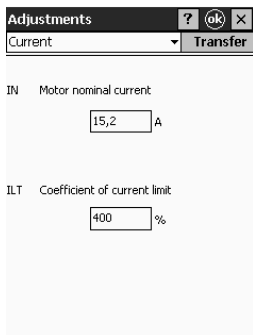

Current setting with PowerSuite on PPC

- Nominal motor current (depends on the soft start rating)
- Limiting current: 400%
- Acceleration ramp time: 15 s
- Initial starting torque: 20%
- Selection of the type of stop: freewheel stop
- Motor thermal protection: class 10
- Time before restarting: 2 s
- Motor phase loss threshold: 10%
- Line frequency: automatic
- RUN and STOP logic inputs: 2-wire or 3-wire control via wiring
- Logic input LI3: forced freewheel stop
- Logic input LI4: local mode control (serial link disabled)
- Logic output LO1: thermal motor alarm
- Logic output LO2: motor powered
- Relay output R1: fault relay
- Relay output R3: motor powered
- Analog output: motor current

Altistart 48 Panel-Mount Soft Starts Functions

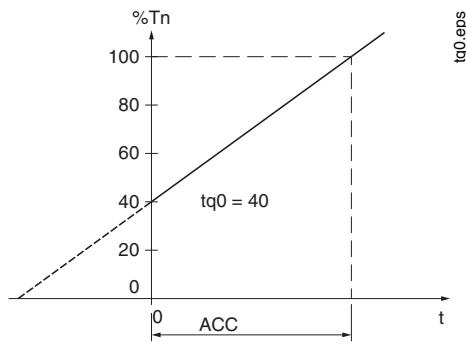

Acceleration ramp during time ACC with initial starting torque $tq_0 = 40\%$ of the nominal motor torque

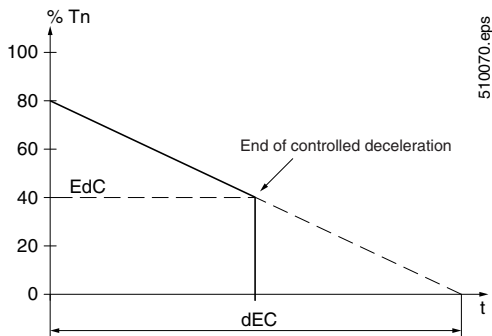

Decelerated stop by torque control during time dEC with threshold EdC for changing to freewheel stop mode
EdC = 40% of nominal motor torque

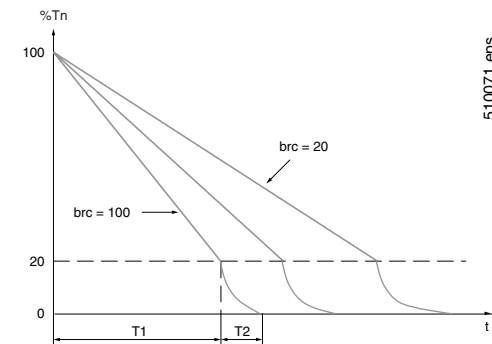

InTele™ braking stops for different braking torque levels brc

Adjustment Functions

- Nominal motor current** (maximum continuous current)
 The nominal current of the soft start can be adapted to the nominal motor current indicated on the nameplate.
 Adjustment range: 0.4 to 1.3 times the soft start nominal current.
- Limiting current**
 The maximum starting current can be adjusted.
 Adjustment range: 150% to 700% of the nominal motor current. Limited to 500% of the maximum permanent current defined for the soft start rating.
- Acceleration ramp time**
 During the starting phase, the ATS48 soft start applies a torque ramp to the motor. The ramp time (ACC) corresponds to the time it takes the ramp to reach the nominal torque (starting at 0). Adjustment range: 1 to 60 s.
- Initial starting torque**
 The initial torque tq_0 applied to the motor can be used to instantly overcome any resistive starting torque. Adjustment range: 0 to 100% of the nominal motor torque.
- Selection of the type of stop**
 Three types of stop are available:

— Freewheel motor stop

— Motor stop by deceleration via torque control (pump application)

This type of stop enables a centrifugal pump to decelerate gradually on a ramp in order to avoid a sudden stop. It can be used to dampen the hydraulic transient in order to significantly reduce pressure surges. The deceleration ramp time (dEC) can be adjusted. During deceleration, the pump flow rate decreases and becomes negligible at a certain speed. To continue to decelerate would serve no purpose. A torque threshold (EdC) can be set at which the motor will change to freewheel stop mode, avoiding the unnecessary heating of the motor and the pump.

— InTele™ braking

The braking torque level (brc) can be adjusted. The dynamic braking time (T1) corresponds to the time taken to decelerate from 100% to 20% of the nominal motor speed. To improve braking at the end of deceleration, the soft start injects a DC current for an adjustable period of time (T2). It produces less motor heating than traditional DC injection braking.

Consult the Schneider Electric Product Support Group (919-266-8600) for criteria to be met for this feature.

Protection Functions

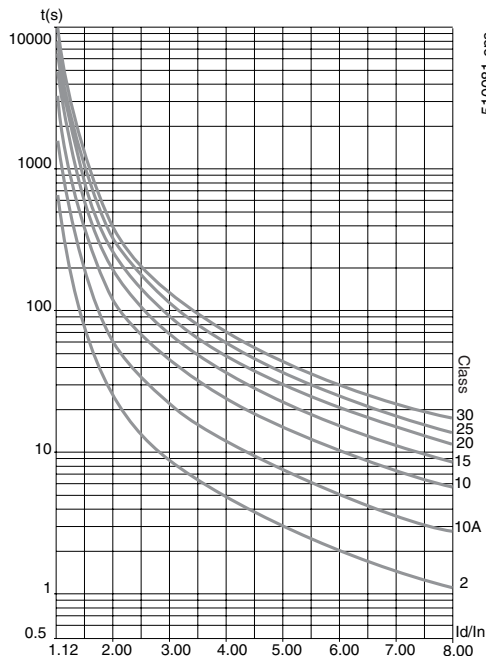

Motor thermal protection curves (cold)

The ATS48 soft start offers functions for protecting the motor and the machine.

- **Calculated motor thermal protection**

The soft start continuously calculates the temperature rise of the motor based on the nominal current and the actual current absorbed. In order to adapt the ATS48 soft start to individual motors and applications, several protection classes are offered in accordance with standard IEC 60947-4-2: Class 30, Class 25, Class 20 (severe duty application), Class 15, Class 10 (standard duty application), Class 10 A, sub-class 2.

Different protection classes are defined for the starting capacities of the motor

- cold start without thermal fault (corresponding to a stabilized motor thermal state, motor switched off)
- warm start without thermal fault (corresponding to a stabilized motor thermal state, at nominal power)

The motor thermal protection function can be disabled.

After the motor has stopped or the soft start has been switched off, the thermal state is calculated even if the control circuit is not energized.

The ATS48 soft start's thermal control prevents the motor from restarting if the temperature rise is too high. If special motors are used which do not have thermal protection, provide external thermal protection via probes or thermal overload relays.

The soft start is factory preset to Class 10.

The tripping curves are based on the relationship between the starting current I_s and the (adjustable) nominal motor current I_n .

Trip time (cold)

Trip time for a standard duty application (class 10)			Trip time for a severe duty application (class 20)		
$I_s = 3 I_n$	$I_s = 4 I_n$	$I_s = 5 I_n$	$I_s = 3.5 I_n$	$I_s = 4 I_n$	$I_s = 5 I_n$
46 s	23 s	15 s	63 s	48 s	29 s

Trip time (warm)

Trip time for a standard duty application (class 10)			Trip time for a severe duty application (class 20)		
$I_s = 3 I_n$	$I_s = 4 I_n$	$I_s = 5 I_n$	$I_s = 3.5 I_n$	$I_s = 4 I_n$	$I_s = 5 I_n$
23 s	12 s	7.5 s	32 s	25 s	15 s

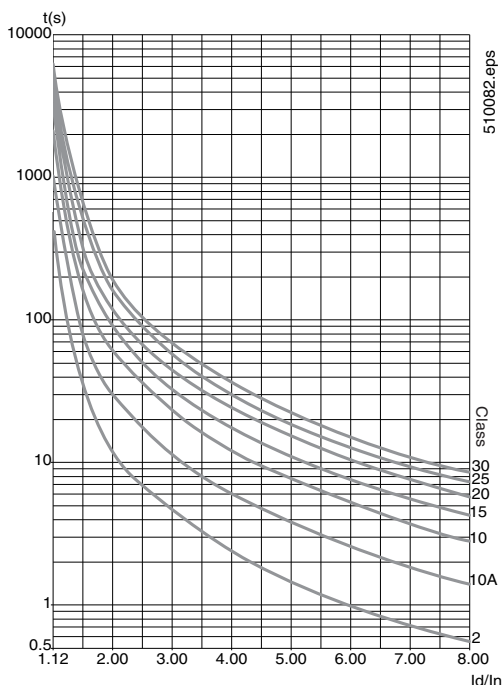

Motor thermal protection curves (warm)

- **Reset motor thermal state**

Activating the function resets the motor thermal state calculated by the soft start to zero.

- **Motor thermal protection with PTC ⁽¹⁾ probes**

PTC probes are integrated into the soft start, thus avoiding the necessity of an external thermal protection device. The "PTC probe thermal overshoot" fault pop alarm can be indicated using a configurable logic output or displayed via the serial link. The function can be disabled.

Note: The PTC probe protection and calculated motor thermal protection functions are independent and can be active simultaneously.

- **Soft start ventilation**

The cooling fan on the soft start is switched on as soon as the heatsink temperature reaches 50 °C (122 °F). It is switched off when the temperature returns to 40 °C (104 °F).

Soft Start Thermal Protection

The soft start is protected against thermal overloads by an analog thermal probe.

⁽¹⁾ PTC: Positive Temperature Coefficient

Altistart 48 Panel-Mount Soft Starts Functions

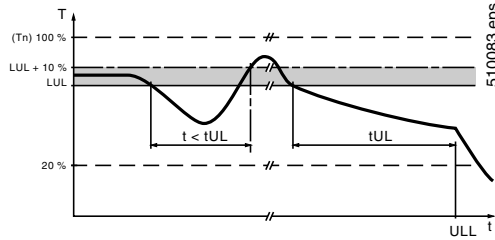

Motor underload detection (ULL)

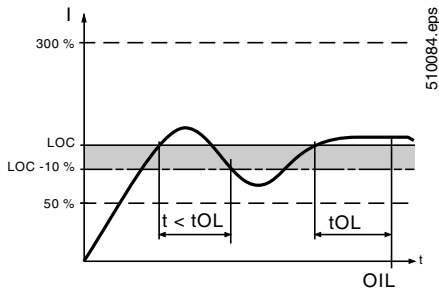

Motor overcurrent detection (OIL)

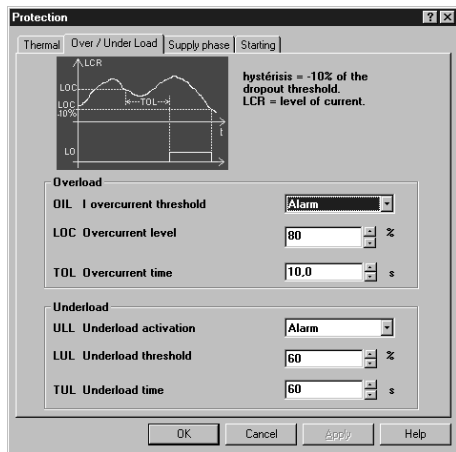

Configuring the starter overload and underload with PowerSuite on a PC

Protection Functions (continued)

- Motor underload protection**
 The soft start detects a motor underload if the motor torque falls below a preset torque threshold (LUL) for a specific (adjustable) period of time (tUL). The motor underload threshold can be set between 20% and 100% of the nominal motor torque. The permissible underload duration can be set between 1 and 60 s. The detection function can trigger an alarm or a fault. The detection function can be disabled. The “motor underload detected” alarm can be indicated by a configurable logic output or displayed via the serial link. The “motor underload detected” fault (ULF) locks the soft start and can be displayed via the serial link.
- Excessive acceleration time protection**
 This protection function can be used to detect a start which takes place in adverse conditions. Examples of such conditions include a locked rotor or a motor unable to reach its nominal rotation speed. If the start duration is longer than the set value (between 10 and 999 s), the soft start enters fault mode. The function can be disabled.
- Current overload protection**
 The soft start detects a current overload if the motor current exceeds a preset overcurrent threshold (LOC) for a specific (adjustable) period of time (tOL). The overcurrent threshold can be set between 50% and 300% of the nominal motor current. The permissible overcurrent duration can be set between 0.1 and 60 s. This function is only active in steady state. The detection function can trigger an alarm or a fault. It can also be disabled. The “current overload detected” alarm can be indicated by a configurable logic output or displayed via the serial link. The “current overload detected” fault (OLC) locks the soft start and can be displayed via the serial link.
- Protection against line phase inversion**
 This function can be used to detect the direction of rotation of the motor phases and, if it is enabled, to indicate a fault when the direction of rotation is reversed.
- Time before restarting**
 This function can be used to avoid several consecutive starts which may cause
 - thermal overheating of the application
 - a thermal fault, which may require maintenance work
 - overcurrents (if the direction of rotation is reversed) or repeats (run/stop commands)
 After a stop command, the motor can only restart after the preset time delay has elapsed. The motor is restarted when the time delay has elapsed if a run command is still valid or if a new run command is sent. Adjustment range: 0 to 999 s.
- Motor phase loss detection**
 The function is used to adjust the sensitivity of the protection function to detect a loss of current or a low current in one of the three motor phases for at least 0.5 s or in all three motor phases for at least 0.2 s. The value of the minimum current level can be set between 5% and 10% of the soft start nominal current.
- Automatic restart**
 This function permits up to six restart attempts after locking on a fault at intervals of 60 s if the cause of the fault has been removed and if the run commands are still present. After the sixth attempt, the soft start remains locked and the fault must be reset before a restart is permitted. If the function is active, the fault relay remains activated if line phase loss, motor phase loss, or line frequency out of tolerance faults are detected. This function can only be used in 2-wire control.

Advanced Adjustment Functions

- **Torque limit**

Designed primarily for high inertia and constant torque conveyor applications, this function restricts the torque ramp reference to the preset value.

For example, the function can be used to limit the torque to a constant value throughout the starting period.

Adjustment range: 10% to 200% of the nominal motor torque.

- **Voltage boost level**

This function can be used to avoid any “starting” torque (phenomenon caused by friction on stopping or by mechanical play). When a run command is sent, the soft start applies a fixed voltage to the motor for a limited period of time before starting. The function can be disabled. The voltage setting value varies between 50% and 100% of the nominal motor voltage.

- **Test on low power motor**

This function can be used to test a starter on a motor whose power is much lower than that of the soft start. It can be used, for example, to check the electrical wiring of a device. The function is automatically cancelled when the soft start is switched off.

The next time the soft start is switched on, the soft start returns to its initial configuration.

- **Activation of the cascade function**

This function can be used to start and decelerate several cascaded motors with a single soft start. In order to gain maximum benefit from torque control, it is advisable to use motors with powers between 0.5 and 1 times the power of the soft start.

- **Line frequency**

The following frequencies can be selected for this function:

- 50 Hz. The frequency fault monitoring tolerance is $\pm 20\%$.
- 60 Hz. The frequency fault monitoring tolerance is $\pm 20\%$.
- Automatic detection of the line frequency by the soft start. The frequency fault monitoring tolerance is $\pm 6\%$.
- 50 Hz and 60 Hz are recommended if the power supply is provided by an emergency standby generator set, given their high tolerance.

- **Reset kWh or the operating time**

Sets the value of the power in kWh or the operating time value to 0. The calculation of the values is updated once the reset command has been sent.

- **Return to factory settings**

This function can be used to reset each setting to its initial value (soft start factory setting, see page 25).

2nd Motor Adjustment Functions

In order to access the 2nd motor adjustment functions, one logic input must be assigned to the second set of motor parameters function. The adjustment functions and ranges are identical for both sets of motor parameters.

The settings are as follows (see page 26):

- Nominal motor current
- Limiting current
- Acceleration ramp time
- Initial starting torque
- Deceleration ramp time
- Threshold for changing to freewheel stop mode at the end of deceleration
- Maximum torque limit

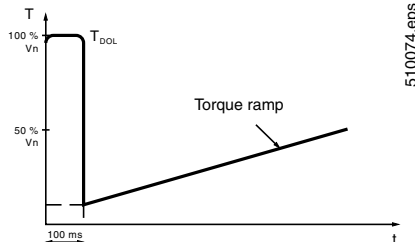

Application of a voltage boost equal to 100% of the nominal motor voltage

Altistart 48 Panel-Mount Soft Starts Functions

Communication Functions

The ATS48 soft start is supplied with an RS-485 multidrop serial link with Modbus® systems protocol as standard. The serial link is configured in the Communication menu using:

- The address of the soft start (0 to 31)
- The communication speed (4800, 9600, or 19200 bps)
- The format of the communication data. The following formats can be selected:
 - 8 data bits, odd parity, 1 stop bit
 - 8 data bits, even parity, 1 stop bit
 - 8 data bits, no parity, 1 stop bit
 - 8 data bits, no parity, 2 stop bits
- The time-out (1 to 60 s)

PowerSuite Advanced Dialog Solutions

The PowerSuite advanced dialog solutions (see page 15) offer the following advantages:

- Connection to the ATS48 soft start and access to the adjustment, monitoring, and control functions
- Display of messages in plain text in 5 languages (English, French, German, Spanish, and Italian)
- Preparation and saving of settings to hard disk
- Comparison and editing of settings using office automation tools
- Downloading of soft start settings to the PC and uploading from the PC to the soft start

Application Monitoring Functions

The monitoring functions provide the following information:

- Power factor, displayed between 0.00 and 1.00
- Motor thermal state: 100% corresponds to the thermal state of the motor consuming the set nominal current
- Motor current: displayed in amperes between 0 and 999 A and in kA between 1000 and 9999 A
- The operating time corresponding to the total number of soft start operating hours during heating, acceleration, steady state, deceleration, braking, and continuous bypass operation. It is displayed in hours between 0 and 999 hours and in kilo hours between 1000 and 65536 hours. The active power is displayed between 0 and 255%, where 100% corresponds to the power at the set nominal current and at full voltage.
- The motor torque is displayed between 0 and 255%, where 100% corresponds to the nominal torque.
- The active power consumed is displayed in kW. The line voltage value must be configured. The accuracy of this setting depends on the error between the voltage configured and the actual voltage.
- Energy in kWh displayed with PowerSuite

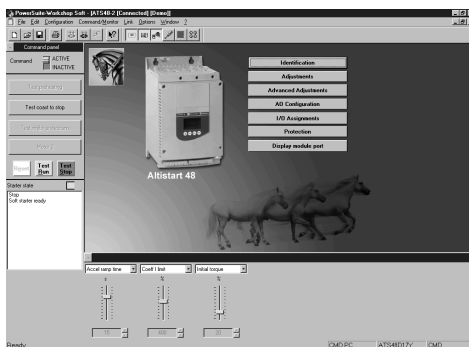

Displaying the commands and settings with PowerSuite on PC

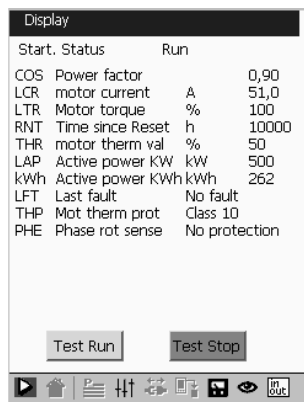

Monitoring the parameters with PowerSuite on PPC

Altistart 48 Panel-Mount Soft Starts Functions

- The following soft start states are shown in the display of the current state:
 - Soft start without a run command and with no power supplied
 - Soft start without a run command and with power supplied
 - Acceleration/deceleration in progress
 - Steady state operation
 - Braking in progress
 - Soft start in current limiting mode
 - Starting time delay not elapsed
- Last fault
- Phase rotation direction. Displays the direction of rotation (direct or indirect).
- **Keypad display locking code**
 - An access code can be used to protect access to the soft start's adjustment and configuration parameters. Only the monitoring parameters are accessible when the adjustment and configuration parameters are locked out.

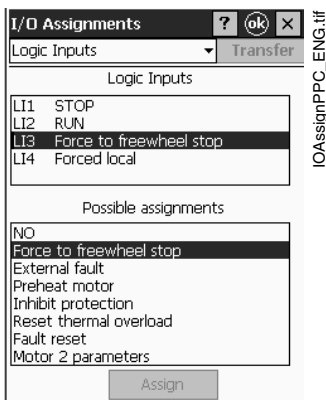

Logic input Application Functions

The soft start has 4 logic inputs:

- **2 logic inputs (RUN and STOP) are reserved for run/stop commands** which can be sent in the form of maintained contacts or as pulsed contacts.
 - **2-wire control:** Starting and stopping are controlled by a single logic input. State 1 of the logic input controls starting and state 0 controls stopping.
 - **3-wire control:** Starting and stopping are controlled by 2 separate logic inputs. A stop is obtained on opening (state 0) the STOP input. The pulse on the RUN input is stored until the stop input opens.
- **2 logic inputs (LI3 and LI4) can be configured with the following functions:**
 - **Freewheel stop:** When combined with a braked stop or decelerated stop command, activating the logic input will stop the motor in freewheel mode.
 - **External fault:** Enables the soft start to detect an external, customer-defined fault (such as level or pressure). When the contact is open, the soft start enters fault mode.
 - **Force to local control mode:** When the soft start is connected to a serial link, this function can be used to change from line mode (control via serial link) to local mode (control via the keypad display).
 - **Reset motor thermal fault:** Enables the motor thermal fault to be reset remotely.
 - **Activation of the cascade function:** With this function active, motor thermal protection is disabled and relay R1 is configured as the fault isolation relay. This function can be used to start and decelerate several motors one after the other with a single soft start.
 - **Reset all faults:** Enables all faults to be reset remotely.
 - **Second set of motor parameters:** Enables a second set of parameters to be selected to start and decelerate two different motors with a single soft start.

Altistart 48 Panel-Mount Soft Starts

Conventional Starting of Three-Phase Asynchronous Motors

Logic Output Application Functions

The soft start has 2 logic outputs (LO1 and LO2) which, depending on their configuration, can be used for remote indication of the following states or events:

- Motor thermal alarm: The motor thermal state has exceeded the alarm threshold. This alarm can be used, for example, to avoid starting a motor if the thermal reserve is insufficient.
- Motor powered: Indicates that there may be current in the motor.
- Motor overcurrent alarm: The motor current is higher than the set threshold.
- Motor underload alarm: The motor torque is lower than the set threshold.
- Motor PTC probe alarm: The thermal state monitored by the PTC motor probe has been exceeded.
- Second set of motor parameters activated

Relay and Analog Output Application Functions

The soft start has 3 relays, 2 of which are configurable.

- **End of starting relay R2:** Cannot be configured. The end of starting relay controls the bypass contactor on the soft start. It is activated when the motor completes the starting phase. It is deactivated when a stop command is sent and in the event of a fault. The soft start regains control when a braking or deceleration command is sent.
- **Relay R1 application functions**
Relay R1 can be configured as follows:
 - **Fault relay:** Relay R1 is activated when the soft start is powered and there are no faults. It is deactivated when a fault occurs and the motor switches to freewheel mode.
 - **Isolating relay:** The contact of relay R1 closes when a run command is sent and re-opens when a stop command is sent, at the end of deceleration on a decelerated stop or in the event of a fault. The line contactor is deactivated and the motor is isolated from the line supply.
- **Relay R3 application functions**
Relay R3 is configured to indicate the same states or events as logic outputs LO1 or LO2 (see page 32).
- **Analog current output AO application function:**
 - Analog output AO provides an image of the following values: motor current, motor torque, motor thermal state, power factor, active power.
 - The following settings are associated with the analog output:
 - The type of signal supplied: 0-20 mA or 4-20 mA
 - The scale setting of the signal. The function associates the maximum amplitude of the analog output (20 mA) with a percentage of the nominal value of the parameter, which can be set between 50% and 500%.

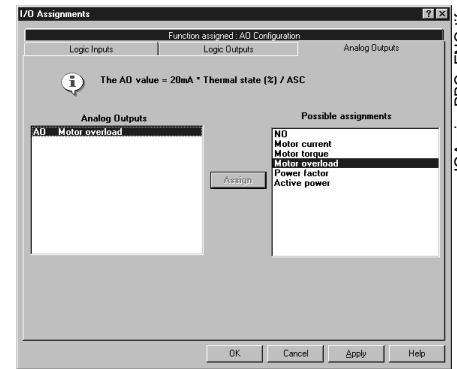

Function Compatibility Table

Functions	Decelerating stop	INTELE™ braking stop	Forced freewheel stop	Thermal protection	Motor phase loss detection	Tests on low power motor	Cascaded motors
Decelerating stop	N/A	N	Y	Y	Y	Y	Y
INTELE™ braking stop	N	N/A	Y	Y	Y	Y	Y
Forced freewheel stop	Y	Y	N/A	Y	Y	Y	N
Thermal protection	Y	Y	Y	N/A	N/A	Y	N
Motor phase loss detection	Y	Y	Y	N/A	N/A	Y	N/A
Tests on low power motor	Y	Y	Y	Y	Y	N/A	N
Cascaded motors	Y	Y	N	N	N/A	N	N/A

Y - Compatible functions

N - Incompatible functions

N/A - Not applicable

Direct starting

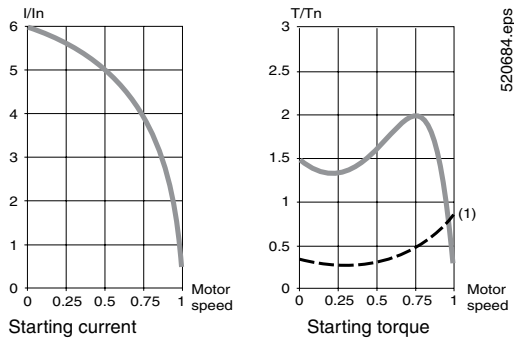

- Starting current: 4 to 8 times the nominal current
- Starting torque: 0.5 to 1.5 times the nominal torque
- Characteristics:
 - Motor with 3 terminals, low and medium power
 - On-load starting
 - High current peak and voltage drop
 - Simple device
 - Sudden starting for the mechanism
- No parameter adjustment

(1) Load torque

Wye Delta starting

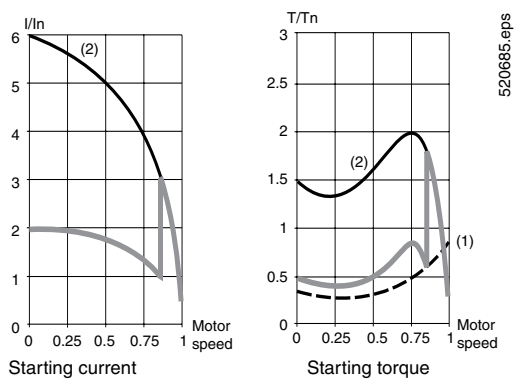

- Starting current: 1.8 to 2.6 times the nominal current
- Starting torque: 0.5 times the nominal torque
- Characteristics:
 - Motor with 6 terminals
 - No-load or low resistive torque starting
 - High current peaks and torque when changing to “Wye Delta” mode
 - A device requiring maintenance
 - Subject to mechanical stress when starting
- No parameter adjustment

(1) Load torque
(2) Direct Starting

Primary resistor starting

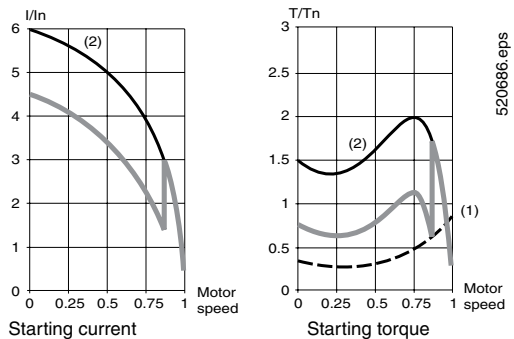

- Starting current: 4.5 times the nominal current
- Starting torque: 0.5 to 0.75 times the nominal torque
- Characteristics:
 - Motor with 3 terminals, high power
 - Starting with increasing resistive torque
 - High current peak
 - A large, bulky device requiring maintenance
 - Subject to mechanical stress when starting
- No parameter adjustment

(1) Load torque
(2) Direct Starting

Autotransformer starting

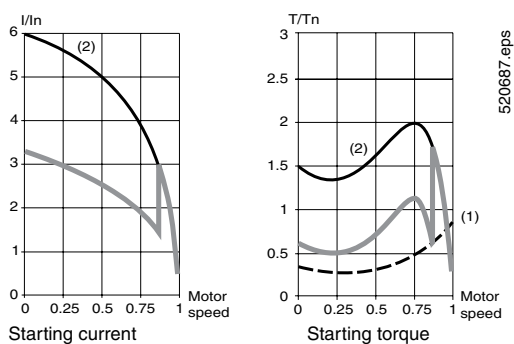

- Starting current: 1.7 to 4 times the nominal current
- Starting torque: 0.4 to 0.85 times the nominal torque
- Characteristics:
 - Motor with 3 terminals, high power
 - Large voltage drop and current peak when connected at full voltage
 - A complex, bulky device requiring maintenance
 - Subject to mechanical stress when starting
- No parameter adjustment

(1) Load torque
(2) Direct Starting

Altistart 48 Panel-Mount Soft Starts

Conventional Starting Curves

Conventional Electronic Starting With Voltage Ramp And Current Limit

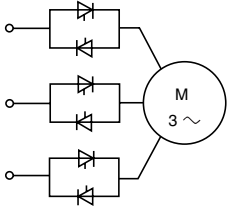

Schematic diagram

520690.eps

- A soft start with 6 thyristors connected head-to-tail in each line phase is used to power the three-phase asynchronous motor by gradually increasing the voltage on start-up.
 - Depending on the firing time and angle of the thyristors, it can be used to supply a voltage which will gradually increase at a fixed frequency.
 - The gradual increase in the output voltage can either be controlled by the acceleration ramp, or by the value of the limiting current, or linked to both parameters.

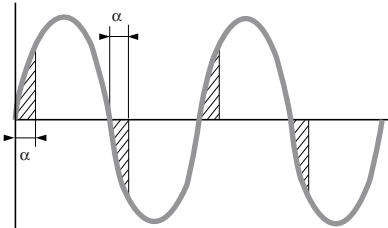

Firing angle

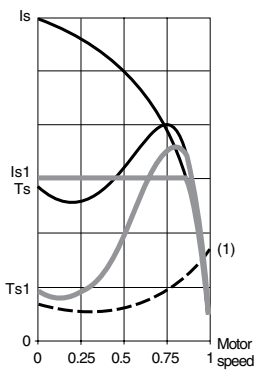

Figure 1

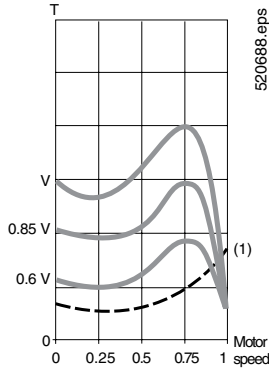

Figure 2

520688.eps

- Figure 1 shows the behavior of the torque in relation to the starting current. Limiting the starting current I_{s1} to a preset value will reduce the starting torque T_{s1} to a value which is almost equal to the ratio of the square of currents I_s and I_{s1} .

Example

On a motor with the following characteristics: $T_s = 2 T_n$ for $I_s = 6 I_n$, current limiting at $I_{s1} = 3 I_n$ or $0.5 I_s$ results in a starting torque: $T_{s1} = T_s \times (0.5)^2 = 2 T_n \times 0.25 = 0.5 T_n$. (T_n is motor rated torque; I_n is motor rated current.)

- Figure 2 shows the torque/speed characteristic of a squirrel cage motor in relation to the supply voltage. The torque varies like the square of the voltage at a fixed frequency. The gradual increase in the voltage prevents the instantaneous current peak on power-up.

(1) Load torque

Advantages of Starting with the ATS48 Soft Start

• Conventional electronic starting

To rectify problems caused by:

- Mechanical stress when starting
- Hydraulic transients during acceleration and deceleration in pump applications

Conventional electronic starting requires the use of several current limits or the switching of several voltage ramps.

The settings become complicated and must be modified every time the load changes.

• Starting with the ATS48 Soft Start

The ATS48 soft start's torque control enables starting without mechanical stress and the smooth control of hydraulic transients with a single acceleration ramp. The settings are simple and effective, whatever the load.

Altistart 48 Panel-Mount Soft Starts

Schneider Electric USA
8001 Highway 64 East
Knightdale, NC 27545
1-888-SquareD
(1-888-778-2733)
www.us.SquareD.com

Schneider Electric Canada
19 Waterman Avenue,
M4B 1 Y2
Toronto, Ontario
1-800-565-6699
www.schneider-electric.ca

Catalog No. 8636CT0201R3/04 March 2004 © 2004 Schneider Electric All Rights Reserved
Replaces 8636CT0201 dated 06/02.