

**ESCUELA SUPERIOR POLITÉCNICA DEL LITORAL**

**Facultad de Ingeniería en Electricidad y Computación**

Diseño e Implementación de una red MODBUS utilizando PLC'S y VFD'S

**PROYECTO INTEGRADOR**

Previo la obtención del Título de:

**Ingeniero en Electricidad especialización Electrónica y  
Automatización Industrial**

Presentado por:

Jairo Antonio Sancán Chóez

Bryan Wladimir Puerto Del Salto

**GUAYAQUIL – ECUADOR**

AÑO: 2018

## **DEDICATORIA**

A Dios, por trazar un camino de prosperidad y darme a conocer personas maravillosas en lo largo de toda mi carrera como estudiante.

A mi madre Emilia quien durante todo este tiempo de mi carrera como estudiante estuvo conmigo muchas veces en noches largas y que cada día se levantaba a dar lo mejor a sus hijos. Además, a mi familia, mi Padre Nelson, mis hermanos Dania, Josué y mis abuelos, a todos ellos por estar siempre juntos tratando de salir de problemas

Por último, a mis amigos por estar siempre en cada broma, fiesta, por sus consejos, gracias por mantener esa amistad a pesar de todos mis defectos.

### **Jairo Antonio Sancán Chóez**

Dedico este trabajo a Dios principalmente; como lo dice su palabra “Y todo lo que hagáis, hacedlo de corazón, como para el Señor y no para los hombres”.

A mis padres, Boris Puero e Ivonne Del Salto quienes siempre depositaron su confianza, esfuerzo y tiempo durante este ciclo. “Oye, hijo mío, la instrucción de tu padre, y no desprecies la dirección de tu madre; porque adorno de gracia serán a tu cabeza, y collares a tu cuello”. A Karen Ochoa quien me supo esperar, escuchar y entender porque “Todo tiene su tiempo, y todo lo que se quiere debajo del cielo tiene su hora”.

Finalmente, a aquellos seres que me robaron el corazón Buper y Lucas, mis fieles amigos.

### **Bryan Wladimir Puero del Salto**

## **AGRADECIMIENTO**

A mis amigos de los Laboratorios de la FIEC por enseñarme lo importante de consolidar lo aprendido en clases y llevarlo a la práctica, al Ing. Luis Fernando Vásquez por enseñarme a querer la electricidad, al Ing. Raúl Intriago por enseñarme que no importa cuánto se deba de invertir en equipos, siempre lo importante es que todos aprendan y compartir los conocimientos, a la Ing. Vanessa Calero, por enseñarme que la amistad siempre estará en todas partes en las buenas y las malas, y a la Economista Hannya Tutiven gracias por acompañarme en las noches de desvelos, calificaciones, amanecidas por todas las sonrisas que me sacas, gracias por estar conmigo.

### **JAIRO ANTONIO SANCÁN CHÓEZ**

Primero agradecer a Dios por darme el privilegio de prepararme. Les agradezco al Ing. Damián Larco Msc., la Ing. Carolina Godoy Msc. y el Ing. Gabriel Intriago, quienes guiaron la ejecución de este proyecto integrador. Al Ing. Luis Fernando Vásquez Msc. por ser un profesor y amigo le agradezco su confianza y predisposición. A mi compañero de tesis Jairo Sancán por ser aquel compañero apropiado al momento de unir capacidades. El amor recibido y la paciencia con la que cada día se preocupaban mis padres, es simplemente único, gracias a ellos quienes han sido los promotores de mis sueños. La vida es hermosa y Dios me regalo una de ellas, Karen Ochoa te agradezco tu confianza y paciencia en este tiempo.

### **BRYAN WALDIMIR PUERO DEL SALTO**

## **DECLARACIÓN EXPRESA**

"Los derechos de titularidad y explotación, nos corresponde conforme al reglamento de propiedad intelectual de la institución; Bryan Wladimir Puerto Del Salto y Jairo Antonio Sancán Chóez damos nuestro consentimiento para que la ESPOC realice la comunicación pública de la obra por cualquier medio con el fin de promover la consulta, difusión y uso público de la producción intelectual"

---

Bryan Wladimir Puerto Del Salto

---

Jairo Antonio Sancán Chóez

## EVALUADORES

.....  
**MSc. Janeth Carolina Godoy Ortega**

PROFESOR DE LA MATERIA

.....  
**MSc. Damián Alberto Larco Gómez**

PROFESOR TUTOR

## RESUMEN

En el presente proyecto se realiza el diseño e implementación de una red Modbus utilizando PLC's y VFD's de diferentes tecnologías, controlado por medio de una web server privada realizada en Visual Studio.

Se programó los PLC's para que funcionen como maestro y los VFD's para que hagan las funciones de esclavo. A continuación, se enviaron los datos de mando usando el protocolo de comunicación Modbus RS 485. Una vez que estuvieron programados los VFD's y los PLC's se procedió a aplicar OPC para poder asignarle una dirección a las variables a usar. Para este ejemplar las variables fueron: marcha, paro, reversa y asignación de velocidad.

Para el control de dichas variables se realizó un SCADA usando el software VISUAL STUDIO, una de las ventajas de este programa es que a más de ser amigable con el usuario resulta ser económico.

Con el propósito de realizar el presente proyecto se requirió un PLC S7-1200, Micro 850, VFD Sinamics V\_20 y un ABB ACS 355. Como resultado se obtuvo que 4 equipos distintos se comunicaron. Adicionalmente, se empleó los siguientes programas: TIA PORTAL, Connected Components, Visual Studio y NI OPC.

**Palabras Claves:** MODBUS, S7-1200, MICRO 850, V\_20, ACS 355.

## **ABSTRACT**

*In the present project the design and implementation of a Modbus network is carried out, using PLC's and VFD's of different technologies, controlled by means of a private web server made in Visual Studio.*

*The PLCs were programmed to function as master and the VFDs to perform the slave functions. Then, the control data was sent using the Modbus RS 485 communication protocol. Once the VFD's and the PLCs were programmed, OPC was applied to assign an address to the variables to be used. For this example, the variables were: march, stop, reverse and speed assignment.*

*To control these variables, a SCADA was performed using the VISUAL STUDIO software, one of the advantages of this program is that, besides being user friendly, it turns out to be economical.*

*In order to carry out the present project, an S7-1200 PLC, Micro 850, VFD Sinamics V\_20 and an ABB ACS 355 were required. As a result, four different computers that communicate were obtained. Additionally, the following programs were used: TIA PORTAL, Connected Components, Visual Studio and NI OPC*

*Keywords: MODBUS, S7-1200, MICRO 850, V\_20, ACS 355.*

# ÍNDICE GENERAL

RESUMEN.....	I
ABSTRACT .....	II
ÍNDICE GENERAL .....	III
ABREVIATURAS.....	V
ÍNDICE DE FIGURAS .....	VI
ÍNDICE DE TABLAS.....	VII
CAPÍTULO 1.....	1
1. Introducción .....	1
1.1 Descripción del problema .....	1
1.2 Justificación.....	2
1.3 Objetivos .....	2
1.3.1 Objetivo General.....	2
1.3.2 Objetivos Específicos.....	2
1.4 Marco teórico.....	3
CAPÍTULO 2.....	8
2. Metodología .....	5
2.1 Descripción del Sistema .....	5
2.2 Software del Sistema.....	6
2.3 Protocolos de Comunicación.....	6
2.4 Comunicación entre Micro850 y Sinamics V20 VFD .....	6
2.5 Comunicación entre Micro850 y ABB ACS355 VFD .....	12
2.6 Comunicación S7-1200 y Sinamics V20 VFD .....	16
2.7 Comunicación S7-1200 y ABB ACS355 VFD.....	21
2.8 Red Industrial .....	24
2.9 Comunicación PLC y PC .....	26
2.10 SCADA.....	29



CAPÍTULO 3.....	35
3. Resultados Y Análisis .....	35
3.1 Análisis de Presupuesto .....	33
3.2 Resultados obtenidos .....	34
CAPÍTULO 4.....	39
4. Conclusiones Y Recomendaciones .....	39
4.1 Conclusiones.....	39
4.2 Recomendaciones.....	41
BIBLIOGRAFÍA.....	
ANEXOS.....	
Anexo A.....	
Anexo B.....	
Anexo C.....	
Anexo D.....	
Anexo E.....	

## **ABREVIATURAS**

ESPOL	Escuela Superior Politécnica del Litoral
VFD	Variador de Frecuencia
HSW	(Haupsollwert) Consigna de velocidad
HIW	(Hauptistwert) Velocidad real
STW	(Steuerwort) Palabra de mando
ZSW	(Zustandswort) Palabra de estado
PLC	Controlador lógico programable
VFD	Variador de frecuencia
SCADA	Supervisión, Control y Adquisición de datos

## ÍNDICE DE FIGURAS

Figura 2.1: Conexiones Eléctricas S7-1200 y V20 .....	7
Figura 2.2. Conexión del Parámetro Cn011 .....	8
Figura 2.3. Bloque de Función de Palabra de Mando del Sinamics V20.....	11
Figura 2.4. Función de envío del código hacia ABB ACS355 .....	14
Figura 2.5. Bloque de escalamiento de la referencia de velocidad.....	15
Figura 2.6. Función de envío de velocidad para variador ABB ACS355.....	15
Figura 2.7. Configuración del módulo CM1241 RS485 en TIA PORTAL.....	17
Figura 2.8. Dirección IP del PLC S7-1200.....	17
Figura 2.9. Bloque de configuración de puerto de salida del S7-1200 .....	18
Figura 2.10. Configuración del S7-1200 como Maestro .....	19
Figura 2.11. Programación de Palabra de mando del V20.....	20
Figura 2.12. Bloque de función de la palabra de mando .....	21
Figura 2.13. Programación de velocidad del variador ACS355 .....	23
Figura 2.14. Dirección de referencia de frecuencia del motor .....	23
Figura 2.15. Función de velocidad del motor desde ACS355.....	24
Figura 2.16. Parámetros de la red LAN y Wireless.....	25
Figura 2.17. DMZ de los dispositivos de la red.....	26
Figura 2.18. Modbus Mapping de Variables Micro850 .....	27
Figura 2.19. OPC de MICRO850 y S7-1200.....	27
Figura 2.20. Variables OPC MICRO850-ABB ACS355 .....	28
Figura 2.21. Variables OPC MICRO850-V20 .....	28
Figura 2.22. Variables OPC S7-1200-ABB ACS355.....	29
Figura 2.23. Variables OPC S7-1200-V20.....	29
Figura 2.24. Jumbotron text-center.....	30
Figura 2.25. Portada Pagina Web .....	30
Figura 2.26. Programación de Botones de interacción.....	31
Figura 2.27: Pantalla Principal con los PLC's .....	31
Figura 3.1. Panel de Variador Siemens V-20 .....	35
Figura 3.2. Conexión entre Micro850 y ACS355 .....	36
Figura 3.3. Perfiles de comunicación en el Variador ACS355.....	37
Figura 3.4. Pantalla principal del SCADA .....	38

## ÍNDICE DE TABLAS

Tabla 2.1. Tabla de Parámetros del Motor .....	7
Tabla 2.2. Tabla de Parámetros de comunicación .....	8
Tabla 2.3. Código Modbus de Registros V20 .....	9
Tabla 2.4. Bits de Palabra de Mando .....	10
Tabla 2.5. Bits de Código de control del ACS-355 .....	12
Tabla 2.6. Parámetros del Motor de Inducción .....	16
Tabla 2.7. Parámetros para comunicación del protocolo Modbus en Sinamics V20 .....	16
Tabla 2.8. Registros Modbus de Estados y manipulación de V20.....	19
Tabla 2.9. Parámetros de datos del motor en el variador ACS355.....	21
Tabla 2.10. Parámetros de comunicación del variador ACS355 .....	22
Tabla 2.11: Direcciones Modbus de Palabra de mando y velocidad ACS355 .....	22
Tabla 2.12. Direcciones IP de los equipos .....	24
Tabla 3.1. Detalles de lista de materiales y precios.....	33

# CAPÍTULO 1

## 1. INTRODUCCIÓN

En el transcurso de la carrera de Electrónica y Automatización no se ha dado énfasis en las diversas formas de comunicar dispositivos industriales. En consecuencia, con el presente trabajo se pretende recalcar las diversas formas de transmitir información entre dispositivos industriales. En el Laboratorio de Electrónica de Potencia de la ESPOL se dispone de diferentes equipos tales como: un PLC S7-1200, un Micro 850, un VFD's y un ABB ACS355. Estos equipos están en desuso, sin embargo, se espera lograr una comunicación entre ellos y controlarlos por medio de una web. Por tal motivo, el presente proyecto se ha planteado realizar la comunicación industrial entre los PLC's y los VFD's de diferentes marcas, utilizando el protocolo Modbus.

### 1.1 Descripción del problema

La industria tecnológica ha dado grandes pasos con el fin de automatizar mecanismos de control, conforme el tiempo avanza los equipos y métodos de automatización van mejorando en eficiencia y eficacia. Sin embargo, en los últimos años la dependencia de ciertas marcas y su monopolización se ha incrementado debido a que ciertos equipos trabajan bajo sus propios productos, viéndose la industria sometida a laborar con un solo proveedor.

En Ecuador estudios de comunicación entre PLC's y VFD's son relativamente escasos y en su gran mayoría son impartidas por marcas de gran influencia que emplean únicamente su propio producto. Pese a ello, estos equipos pueden comunicarse con dispositivos de diferente fabricante, el problema nace en la escasa información acerca de la independencia de los productos y sus protocolos a usar para esta comunicación. Estas capacitaciones que por lo general se imparten, suelen ser entre un PLC de gama media o alta con un variador de la misma marca.

Además, cabe mencionar que los equipos son controlados de manera local, provocando una estancia permanente en el lugar de trabajo, lo cual genera otra problemática debido a que estos mecanismos sólo pueden ser supervisados en una

sola área y el sistema de SCADA usado por lo general es costoso, y existe una licencia de adquirir; que a su vez viene limitada por el número de equipos que use el software.

## **1.2 Justificación**

La relevancia radica en la independencia de marcas, ya que, al realizar la comunicación entre dispositivos de diferentes fabricantes, se obtendrá una autonomía de vital importancia en cualquier industria. Además, como se citó, existe una escasa información sobre este tipo de enlace; por ello la información obtenida a través de este proyecto servirá como aporte tecnológico a la ESPOL, impulsando nuevos campos de estudio y capacitaciones.

De la misma manera, el proyecto se vuelve oportuno para el ahorro de licencias costosas que uno adquiere al realizar un sistema SCADA, usando un software libre y totalmente gratuito, además se aplicará una web Server para desligar al operador de un sólo lugar de trabajo, dándole la libertad de controlar y manipular el sistema SCADA de forma remota, mediante una IP privada facilitada por la ESPOL.

Finalmente, se puede decir que el trabajo aportará a la ESPOL con una diversidad de información: uniendo marcas, usando software libre y creando una Web Server que ayudará al estudiante a tener una mejor formación profesional.

## **1.3 Objetivos**

### **1.3.1 Objetivo General**

Aplicar la comunicación entre PLC's y VFD's de diferentes marcas, implementando una red Modbus, software libre y un sistema SCADA, para la independencia de fabricantes.

### **1.3.2 Objetivos Específicos**

- Diseñar un sistema SCADA usando Visual Basic.NET, con un PLC siemens S7-1200 y un micro 850.
- Integrar los variadores siemens v20 y ABB ACS355, usando el PLC s7-1200 y el micro 850.
- Manipular de forma parcial las variables del SCADA remotamente, realizando una Web Server con IP privada.

## 1.4 Marco teórico

A nivel nacional el estudio de la comunicación entre dispositivos ha llegado a realizarse hasta en equipos del mismo fabricante tal como es el caso del PLC SIEMENS S7-1200 y el VFD SIEMENS V\_20, de este estudio mencionado se tomará el tipo de secuencia que se usa, y los parámetros relevantes. Por otro lado, los sistemas SCADA pueden ser utilizados en diferentes software, entre ellos LabView, Visual Studio, HMI, por cuestiones económicas se realizará este proyecto con Visual Studio.

Cabe recalcar que únicamente para este proyecto en específico se nombrarán las marcas de los equipos por motivo de la demostración de la independencia del fabricante.

Se procederá a dar una descripción de cada equipo y/o herramienta utilizado además de los diversos softwares manejados.

Proyectos integradores realizados en Cataluña titulado Programación e implementación de software de control para autómatas Siemens por internet se basa en el diseño de una aplicación Windows para uso industrial. Dicho proyecto detalla métodos en la programación del SCADA y su creación de variables en la PC. Para esto es imprescindible contar con el PLC S7-1200 con el que se establece el canal de comunicación junto a su router asignándole una IP fija al PLC y de esta forma realizar tener de forma remota el control del PLC y la PC. Por otro lado, en el SCADA se usa una programación C# y C++ usando Windows forms. Con esta aplicación se puede visualizar y editar valores de las variables internas de un autómata programable remotamente, tener acceso al histórico de alarmas de la máquina conectada y centralizar la visualización de documentación [1]. Con dicha investigación se puede iniciar la emigración de variables del PLC al computador.

En la universidad Pontificia Bolivariana de Bucaramanga se implementó una interfaz gráfica para la supervisión de un motor mediante el protocolo modbus TCP-IP. Esta interfaz fue programada en Visual Basic para la supervisión de datos de un PLC TWD 07 mediante el protocolo Modbus TCP/IP. Las variables que puede controlar el SCADA son encendido y apagado del motor, asignación de velocidad e inversión de giro. La asignación de velocidad se la realiza mediante una normalización del vector de velocidad realizando una analogía entre

frecuencia y velocidad [2]. Este método de programación usado con la asignación de velocidad se la puede implementar en el proyecto para controlar las velocidades que se le asignación tanto al variador SINAMICS V\_20 y el ABB ACS 355.

En el manual del PLC SIEMENS S7-1200, capítulo 13 indica el procesador de comunicación y MODBUS TCP, en dicho capítulo se explica los módulos de comunicación compatibles con el PLC entre esos el RS-485. Este módulo de comunicación tiene su polarización y resistencias de fin de línea para su correcto funcionamiento. A su vez este manual indica la forma cíclica de programación de bloques para la comunicación entre PLC y variadores de frecuencia utilizando los bloques mm\_com load y mb\_master [3].

Finalmente recopilando toda esta información se puede concluir que el sistema de comunicación a implementar se basará inicialmente en la colocación de todos los dispositivos conectados en una misma red, es decir se colocará un router para que direcciona una IP al computador, al S7-1200 y las MICRO\_850. Cuando la red esté establecida se procederá a realizar la programación de cada PLC y se los configurará como Maestros en la red Modbus, estos dispositivos enviarán las diversas órdenes o comandos hacia los variadores. Para el caso del software de los PLC's se utilizará el protocolo modbus RTU, teniendo de esta forma la comunicación entre el PLC y VFD. Para la creación de variables en la PC se utilizará NI OPC SERVER. Una vez creado estas variables, se puede realizar el SCADA en el Visual Studio usando el protocolo modbus TCP/IP.



# CAPÍTULO 2

## 2. METODOLOGÍA

Para la implementación de dicho proyecto se plantearon una serie de opciones. Para la comunicación entre variador de frecuencia y PLC existen diversos protocolos tales como ETHERNET, PROFIBUS, CANOPEN, MODBUS, etc. Se utilizó MODBUS por la distancia que puede recorrer ésta sin afectar los niveles de voltaje con la cual transmite la trama, ventaja que no ofrecen los demás protocolos. Para la creación de las variables se tenían como opciones keepserver y NIOPC, ambas tienen un costo para su uso para este caso se usó NIOPC debido a que la ESPOL ya cuenta con dicha licencia. Por último, para la realización del SCADA se tenían como alternativas LabView y Visual Studio a pesar de que la ESPOL cuenta con LabView se escogió Visual porque es de uso gratuito.

Teniendo en cuenta las diversas soluciones del presente proyecto se lo realizó por secciones, atendiendo cada comunicación entre el PLC y el VFD de manera independiente. Posteriormente, se creó la red industrial para de esta forma emigrar la información necesaria a un sistema SCADA.

A continuación, se detalla cada sección:

### 2.1 Descripción del Sistema

El sistema de comunicación se basará inicialmente en la colocación de todos los dispositivos conectados en una misma red, es decir se colocará un router para que direcciona una IP al computador, al S7-1200 y las MICRO\_850. Cuando la red esté establecida se procederá a realizar la programación de cada PLC y se los configurará como Maestros en la red Modbus, estos dispositivos enviarán las diversas órdenes o comandos hacia los variadores.

Los motores por usar serán jaula de ardilla cada uno de ellos serán conectados a un variador de frecuencia. Para el caso de los variadores ambos serán vinculados a cada uno de los PLC's, y finalmente los PLC's al computador.

## **2.2 Software del Sistema**

Los softwares que se utilizarán son: Visual Basic.NET como de SCADA además de un servidor OPC, luego el MICRO\_850 con CCW y en S7-1200 que se realiza su programación en TIA PORTAL.

Inicialmente toda la programación será realizada por bloques en los softwares propios del fabricante, una vez realizada esta programación con sus respectivas pruebas se debe enviar la trama de comunicación usando el software OPC SERVER de esta forma se creará las variables a usar tales como: marcha, paro, reversa y consigna de velocidad, cada una de ellas tendrá una trama diferente.

Por tema de confiabilidad se usará el software Serial Port Monitor este programa ayudará a identificar qué información es la que se está enviando.

## **2.3 Protocolos de Comunicación**

Para el caso del software de los PLC's se utilizará el protocolo Modbus RTU, consiguiendo de esta forma la comunicación entre el PLC y VFD. Para la creación de las variables en la PC se utilizará NI OPC SERVER. Una vez creadas estas variables, se procede a realizar el SCADA en el Visual Studio usando el protocolo modbus TCP/IP.

## **2.4 Comunicación entre Micro850 y Sinamics V20 VFD**

Para realizar la comunicación entre el PLC Micro850 y el Sinamics V20 VFD se estableció una comunicación vía Modbus RTU.

Las conexiones eléctricas que se realizaron desde el variador hacia el PLC fueron las siguientes:

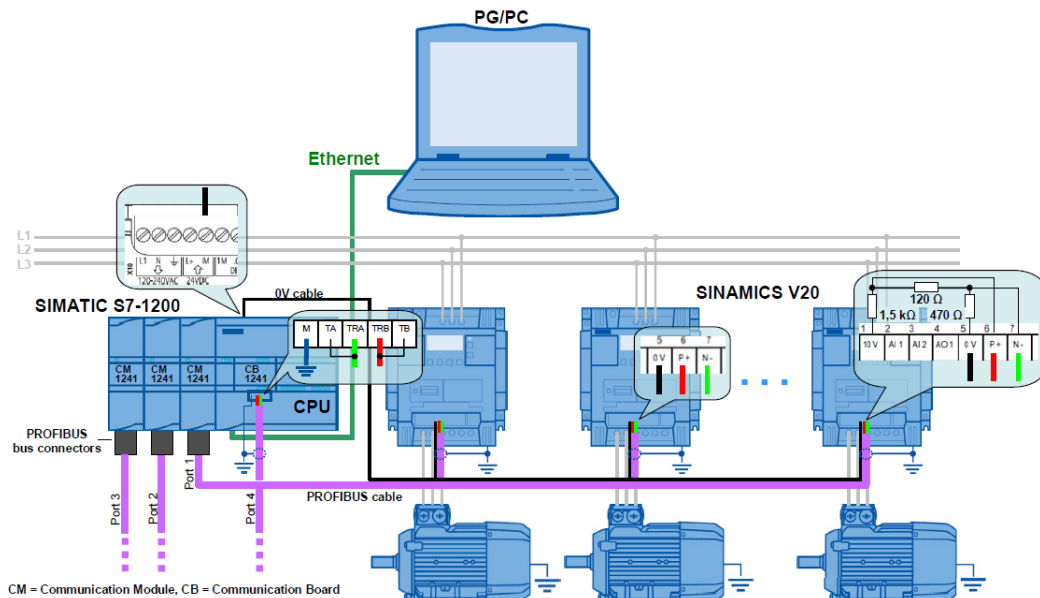

**Figura 2.1: Conexiones Eléctricas S7-1200 y V20**

Luego de la interfaz eléctrica se enciende el variador y se configuran los parámetros del VFD los cuales se muestran en la siguiente tabla:

**Tabla 2.1. Tabla de Parámetros del Motor**

Parámetro	Uso	Valor
P304	Tensión nominal del motor de la placa de características.	220 Voltios
P305	Corriente nominal del motor de la placa de características.	6.95 Amperios
P307	Potencia nominal del motor [kW/hp] de la placa de características.	1.5 KW
P308	Factor de potencia ( $\cos\phi$ ) nominal del motor de la placa de características.	0.79
P310	Frecuencia nominal del motor de la placa de características.	50 Hz
P311	Velocidad nominal del motor de la placa de características.	1400 RPM

Posterior a esto se colocó los parámetros del motor y se configuró los parámetros de comunicación del protocolo MODBUS RTU los cuales se debían habilitar en la Macro 11 del variador.



Figura 2.2. Conexión del Parámetro Cn011

Tabla 2.2. Tabla de Parámetros de comunicación

Parámetro	Descripción	Ajustes predeterminados de fábrica	Ajustes predeterminados de Cn011	Observaciones
P0700(0)	Selección de la fuente de señales de mando	1	5	RS485 como la fuente de señales de mando
P1000(0)	Selección de frecuencia	1	5	RS485 como la consigna de velocidad
P2023(0)	Selección de protocolo RS485	1	2	Protocolo MODBUS RTU
P2010(0)	Velocidad transmisión USS/MODBUS	8	6	Velocidad transmisión 9600 bps
P2021(0)	Dirección MODBUS	1	1	Dirección MODBUS para convertidor
P2022(0)	Tiempo excedido de respuesta MODBUS	1000	1000	Tiempo máximo para enviar la respuesta de vuelta al maestro

P2014(0)	Tiempo de interrupción de telegrama USS/MODBUS	2000	100	Tiempo para recibir datos
----------	--	------	-----	---------------------------

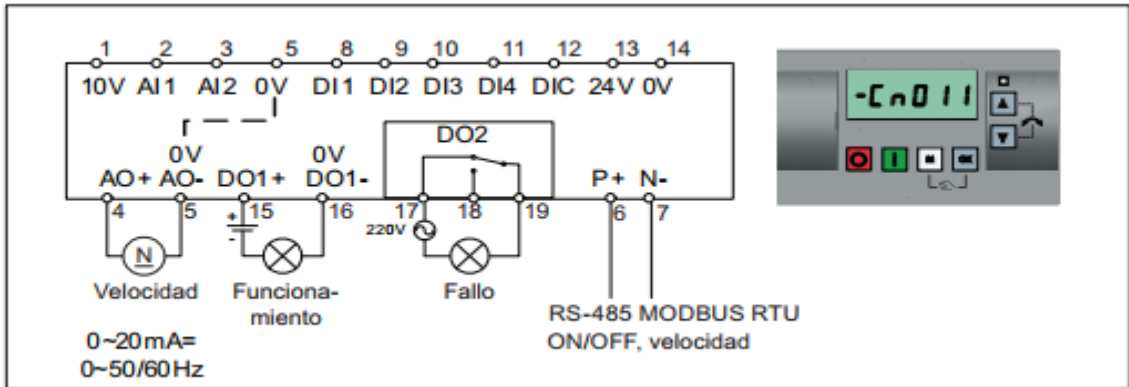
Una vez que se configuraron los parámetros de comunicación se pudo proceder a enviar una trama Modbus para leer o escribir algún parámetro.

Para realizar el envío de alguna trama desde la programación en el Connected Components Workbench se debió tener en cuenta que en un mensaje de datos de Modbus el registro 4xxxx se direcciona como xxxx - 1.

Por ejemplo, el registro 40002 se direccionó como 0001

Los parámetros que se configuraron en el variador fueron:

- HSW (Hauptsollwert): Consigna de velocidad
- HIW (Hauptistwert): Velocidad real
- STW (Steuerwort): Palabra de mando
- ZSW (Zustandswort): Palabra de estado

Los registros Modbus se muestran a continuación:

**Tabla 2.3. Código Modbus de Registros V20**

Convertidor	MODBUS	Variable	Acceso
99	40100	HSW	R/W
100	40101	HIW	R/W
109	40110	STW	R
110	40111	ZSW	R

Los bits de la palabra de mando de muestran a continuación:

**Tabla 2.4. Bits de Palabra de Mando**

<b>BIT</b>	<b>NOMBRE DE SEÑAL</b>
00	ON/OFF1
01	OFF2: Parada Natural
02	OFF3: Parada Rápida
03	Habilitación de impulsos
04	Habilitación de GdR
05	Arranque de GdR
06	Habilitación de consigna
07	Confirmación de fallo
08	JOG a la derecha
09	JOG a la izquierda
10	Mando desde PLC
11	Inversión de Giro
13	Subir Potenciómetro (MOP)
14	Bajar Potenciómetro (MOP)
15	CDS, bit 0 (manual/automático)

La palabra de mando está compuesta por 16 bits y cada uno de ellos tiene una labor específica.

El bit 00 permite encender y apagar el motor dependiendo si está activado o no.

El bit 01 permite frenar el motor por rampa de desaceleración.

El bit 02 permite frenar el motor por inercia, es decir se corta el suministro de energía directamente sin realizarlo de manera constante.

El bit 03 permite la habilitación de impulsos

El bit 04 habilita el giro del motor

El bit 05 permite arrancar el motor

El bit 07 permite el ingreso de la velocidad desde el PLC

El bit 8 mover el teclado BOP hacia la derecha

El bit 9 mover el teclado BOP hacia la izquierda

El bit 10 permite un control remoto al variador, sin él no se podría enviar ninguna trama

El bit 11 si está habilitado permite el cambio de giro del motor de forma externa.

El bit 12 es reservado por el fabricante.

El bit 13 Permite cambiar la velocidad del motor desde el PLC, Hacia arriba

El bit 14 Permite cambiar la velocidad del motor desde el PLC. Hacia abajo  
El bit15 indica si existen errores en la traba de envío del micro 850.

A continuación, se describe el bloque de programación de la palabra de mando del variador V20.

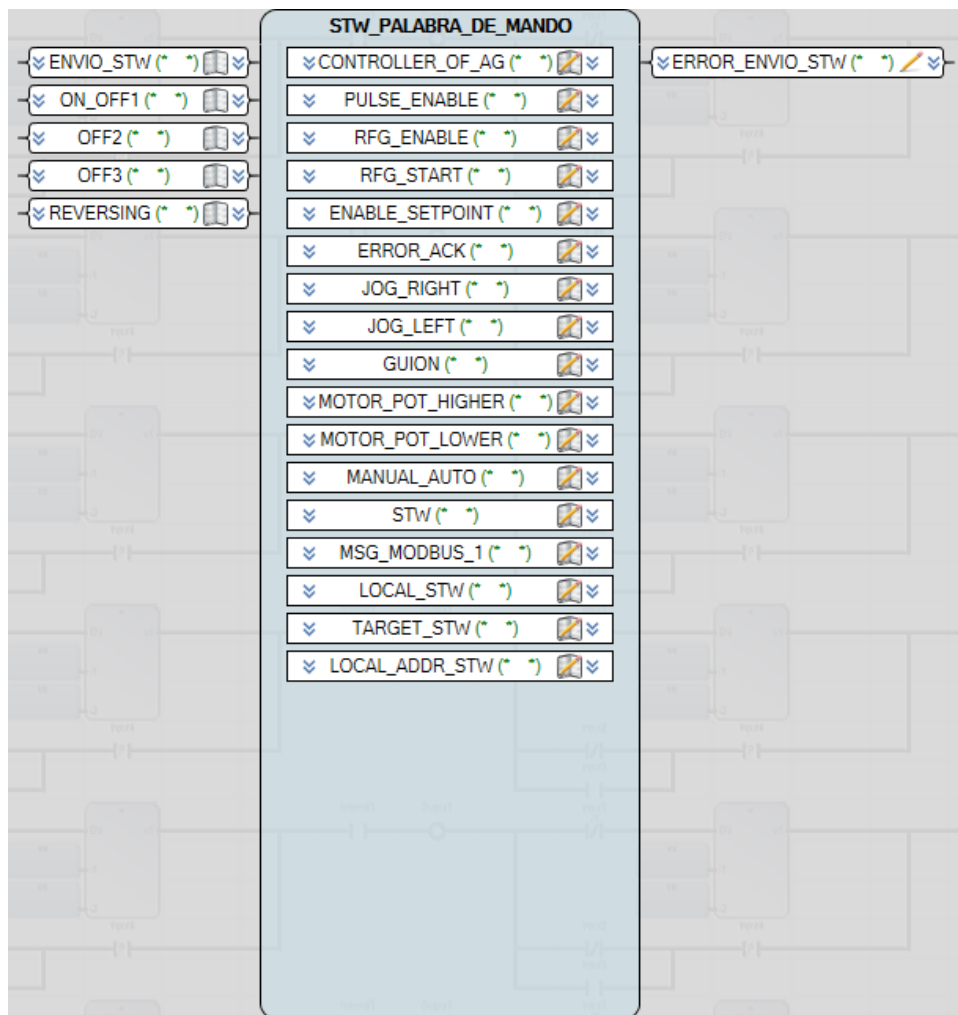

**Figura 2.3. Bloque de Función de Palabra de Mando del Sinamics V20**

En el bloque mostrado de todas las opciones que presentan la palabra de mando se encuentran como variables de entrada y de salida:

ENVI0\_STW: el cual envía la palabra de mando cuando se encuentra activado.

ON\_OFF1: encender y apagar el motor

OFF2: Parada por rampa

OFF3: Parada por inercia.

REVERSING: Reversa del Motor o cambio de giro.

ERROR\_ENVIO\_STW: Este error se activa cuando no se pudo establecer comunicación con el variador.

## 2.5 Comunicación entre Micro850 y ABB ACS355 VFD

Para la comunicación entre el Micro 850 y el variador ACS355 se consideraron los mismos aspectos tales como “la palabra de mando”, y “la referencia de velocidad”. La palabra de mando o también llamado código de control del variador depende de los parámetros establecidos en el mismo, el variador posee 3 perfiles de envío de palabras de mando, el perfil ABB limitado, el ABB completo y el DCU. Los dos primeros son propietarios de la marca ABB es decir, solo se utilizan para establecer una comunicación entre dispositivos de la misma marca, el perfil DCU es abierto a cualquier otra marca y está compuesta de 32 bits los cuales se dividen de la siguiente manera: el DCU más significativos y DCU menos significativos. Para el envío de éstos, solo se debió enviar los 16 bits menos significativos para poder dar marcha, frenado y cambio de giro del motor de inducción.

**Tabla 2.5. Bits de Código de control del ACS-355**

BIT	NOMBRE	VALOR	DESCRIPCIÓN
0	PARO	1	Paro según el parámetro de modo de paro (2102) o las peticiones de modo de paro (bits 7 y 8).
		0	No está en funcionamiento.
1	MARCHA	1	Marcha
		0	No está en funcionamiento.
2	RETROCESO	1	Dirección de retroceso.
		0	Dirección de avance.
3	LOCAL	1	Entrar en modo de control local.
		0	Entrar en modo de control externo.
4	REARME	1	Restauración.
		0	No está en funcionamiento.
5	EXT2	1	Cambio a control externo EXT2.
		0	



			Cambio a control externo EXT1.
6	RUN_DISABLE	1	Activar la inhabilitación de marcha.
		0	Activar el permiso de marcha.
7	STPMODE_R	1	Paro por la rampa de deceleración
		0	No está en funcionamiento.
8	STPMODE_EM	1	Paro de emergencia.
		0	No está en funcionamiento.
9	STPMODE_C	1	Usar el par de rampas de aceleración/deceleración
		0	Usar el par de rampas de aceleración/deceleración
10	RAMP_2	1	Usar el par de rampas de aceleración/deceleración
		0	Usar el par de rampas de aceleración/deceleración
11	RAMP_OUT_0	1	Forzar a cero la salida de rampa.
		0	No está en funcionamiento.
12	RAMP_HOLD	1	Detener la rampa
		0	No está en funcionamiento.
13	RAMP_IN_0	1	Forzar a cero la entrada de rampa.
		0	No está en funcionamiento.
14	REQ_LOCALLOC	1	Habilitar el bloqueo local.
		0	No está en funcionamiento.
15	TORQLIM2	1	Usar el límite de par máximo/mínimo 2
		0	Usar el límite de par máximo/mínimo 1

Una vez conocido el bit del código de control se procedió a realizar la programación en CCW.

Para la programación se realizó una función que contenga todos los bits del código de control, además sólo se tuvo acceso a los bits de marcha, paro, y reversa. Así

mismo, el bloque contó con un error de envío si el variador no respondió a la palabra de mando del PLC.

Se debe considerar que los registros tales como LOCAL, REARME se encontraron activados internamente en la función, dado que LOCAL permitió el control de forma remota cuando estuvo desactivado y REARME permitió guardar los cambios en la memoria del variador cuando se quitó la energía y se apagó el equipo.

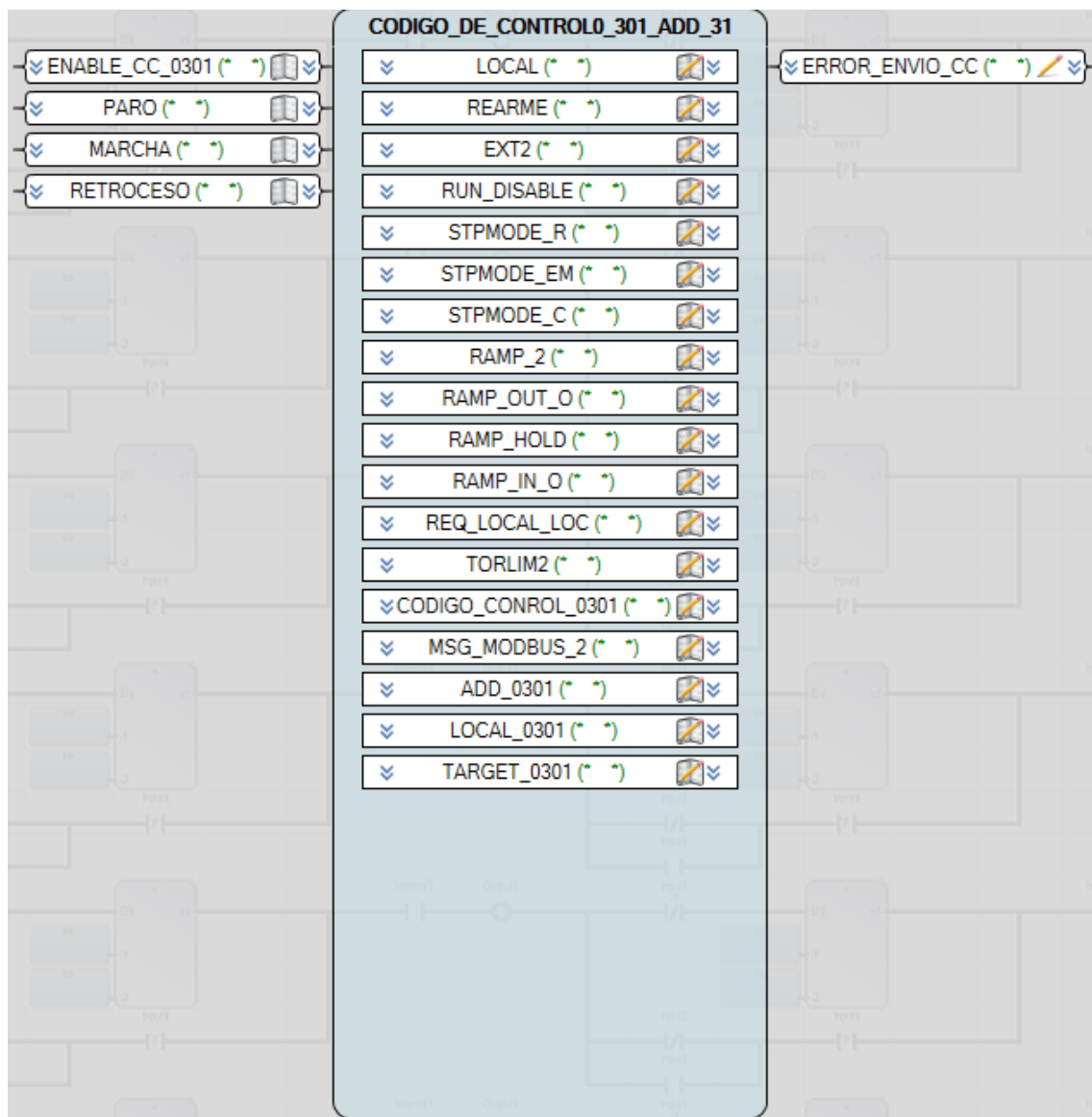

**Figura 2.4. Función de envío del código hacia ABB ACS355**

Para el envío de la velocidad de referencia se tuvo que considerar un escalamiento de los datos dado que el variador solamente aceptó números entre el rango de 0

y 20000, es decir 0 equivalió a la frecuencia mínima del motor 0HZ y 20000 fue la frecuencia máxima del motor 50 HZ.

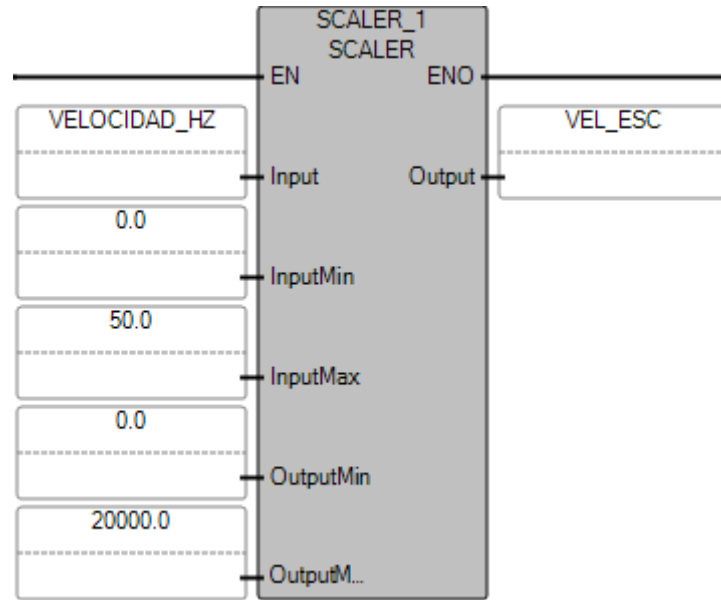

**Figura 2.5. Bloque de escalamiento de la referencia de velocidad**

Para el mejor funcionamiento de la velocidad del motor se procedió a realizar una función para el cambio de velocidades

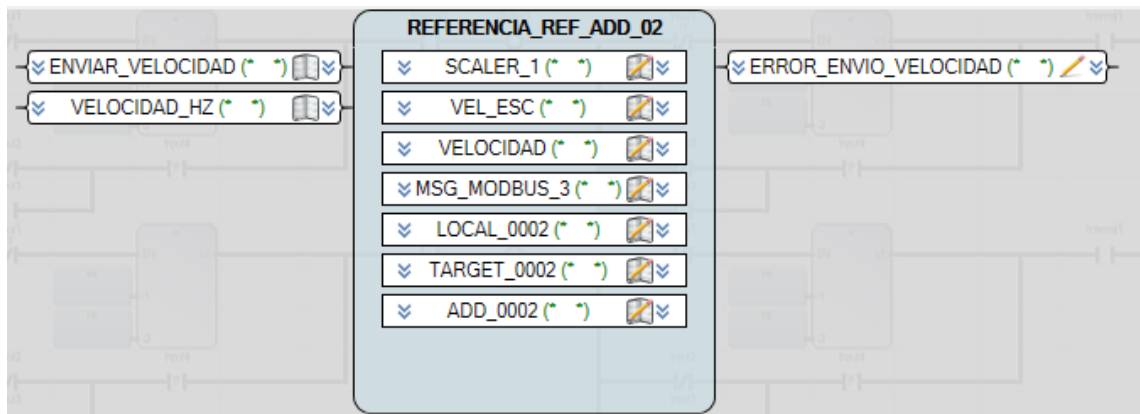

**Figura 2.6. Función de envío de velocidad para variador ABB ACS355**

En el bloque de programación Modbus se debió enviar a la dirección del variador ADR: 000002, en la cual se escribió la frecuencia de giro del motor.

Si el bloque de envío de datos no estableció comunicación entre el PLC y el variador se procedió a activar la salida ERROR\_ENVIO\_VELOCIDAD, lo cual indicó que existió un error. Este error pudo ser debido a la mala conexión de las

borneras al adaptador de bus de campo del variador. Se debe considerar que las resistencias de terminación, sólo se debían utilizar cuando hubo más de un esclavo en la misma línea de comunicación del PLC.

## 2.6 Comunicación S7-1200 y Sinamics V20 VFD

Inicialmente se configuró los parámetros del variador, que correspondió a los datos de placa del motor AC que se va a energizar.

Estos parámetros fueron los siguientes:

**Tabla 2.6. Parámetros del Motor de Inducción**

<b>P0304</b>	Tensión Nominal
<b>P0305</b>	Corriente Nominal
<b>P0307</b>	Potencia Nominal
<b>P0308</b>	Factor de Potencia
<b>P0310</b>	Frecuencia Nominal
<b>P0311</b>	Velocidad Nominal

Posteriormente se configuró los parámetros para la comunicación del variador V\_20 al módulo de comunicación 1241 del PLC S7-1200. Estos parámetros fueron los siguientes:

**Tabla 2.7. Parámetros para comunicación del protocolo Modbus en Sinamics V20**

<b>P0003</b>	<b>Access Level</b>	<b>3</b>
<b>P0010</b>	Commissioning Parameter	30
<b>P0970</b>	Factory Reset	21
<b>P2010</b>	Baudrate	9600
<b>P2023</b>	RS485 protocol	2

Una vez configurado completamente el variador se procedió a comunicar el PLC junto con el módulo de comunicación 1241 RS485 y con la PC donde se realizó el ejecutable.

Para ello, primero se configuró el módulo 1241 indicando la velocidad de transmisión, paridad, bit de datos, bit de parada y control de flujo.

Velocidad de transferencia:	9.6 kbits
Paridad:	Sin paridad
Bits de datos:	8 bits por carácter
Bit de parada:	1
Control de flujo:	Ninguno
Carácter XON (HEX):	0
(ASCII):	NUL
Carácter XOFF (HEX):	0
(ASCII):	NUL
Tiempo de espera:	1 ms

**Figura 2.7. Configuración del módulo CM1241 RS485 en TIA PORTAL**

Posteriormente, se configuró el S7-1200, asignándole una IP para crear una Red industrial privada.

Interfaz conectada en red con	
Subred:	PN/IE_1
Agregar subred	
Protocolo IP	
<input checked="" type="radio"/> Ajustar dirección IP en el proyecto	
Dirección IP:	192 . 168 . 0 . 105
Másc. subred:	255 . 255 . 255 . 0
<input checked="" type="checkbox"/> Utilizar router	
Dirección del router:	192 . 168 . 0 . 1
<input type="radio"/> Permitir ajustar la dirección IP directamente en el dispositivo	

**Figura 2.8. Dirección IP del PLC S7-1200**

De esta forma se obtuvo la comunicación entre el PLC y la PC.

Posteriormente se realizó la programación respectiva para la comunicación industrial. Como el protocolo de comunicación a usar es Modbus, se debe tener claro el uso de los bloques M\_MASTER y M\_COMM\_LOAD.

### Segmento 3: INICIO\_COMUNICACION\_MODBUS

Comentario



Figura 2.9. Bloque de configuración de puerto de salida del S7-1200

Con este bloque se inicializó el protocolo Modbus sea este 232 o 485, en donde en el port se declaró el módulo de comunicación que se configuró anteriormente, a su vez en BAUD se ubicó la misma velocidad en baudios del VFD y la compuerta MB\_DB llamó al bloque MB\_MASTER que correspondió a la trama de 8 bits que se envió al VFD.

Es importante conocer que se envió en la trama. Esta trama de ocho bits puede contener: palabra de mando, consigna de velocidad, palabra de estado y velocidad real.

**Tabla 2.81. Registros Modbus de Estados y manipulación de V20**

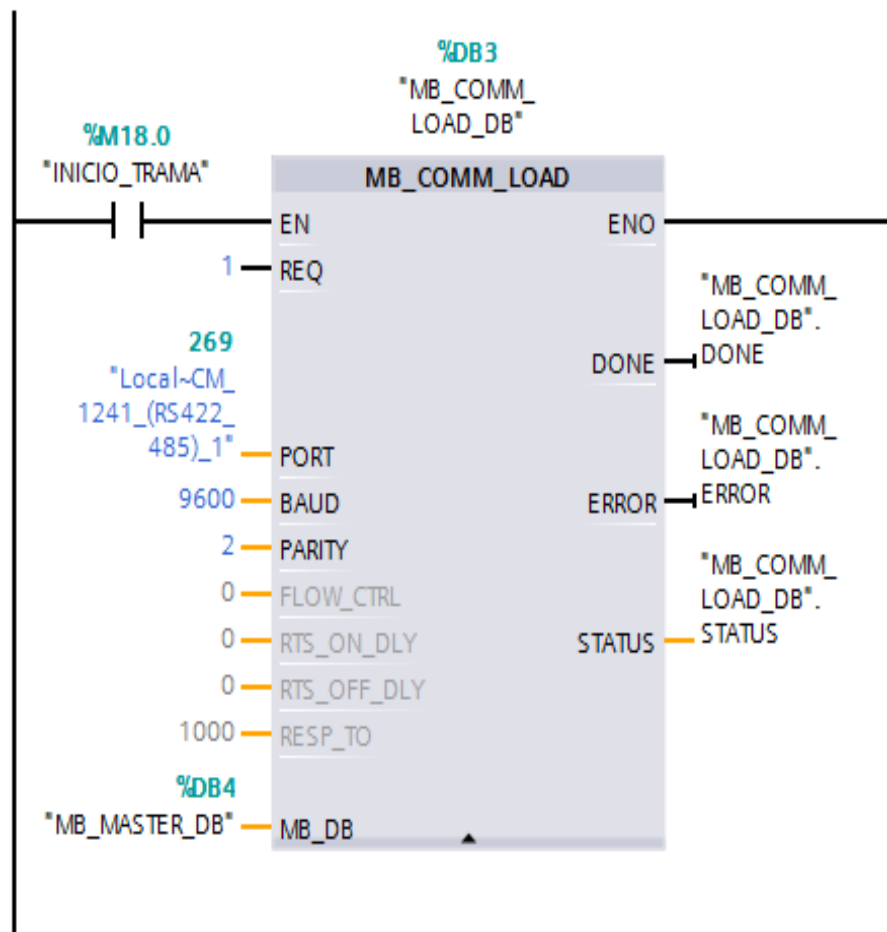
	Parámetro	Dirección
<b>STW</b>	Palabra de Mando: Paro o Marcha	40100
<b>HSW</b>	Consigna de Velocidad	40101
<b>HIW</b>	Lectura de Velocidad Real	40111
<b>ZSW</b>	Lectura de Palabra de Estado	40110

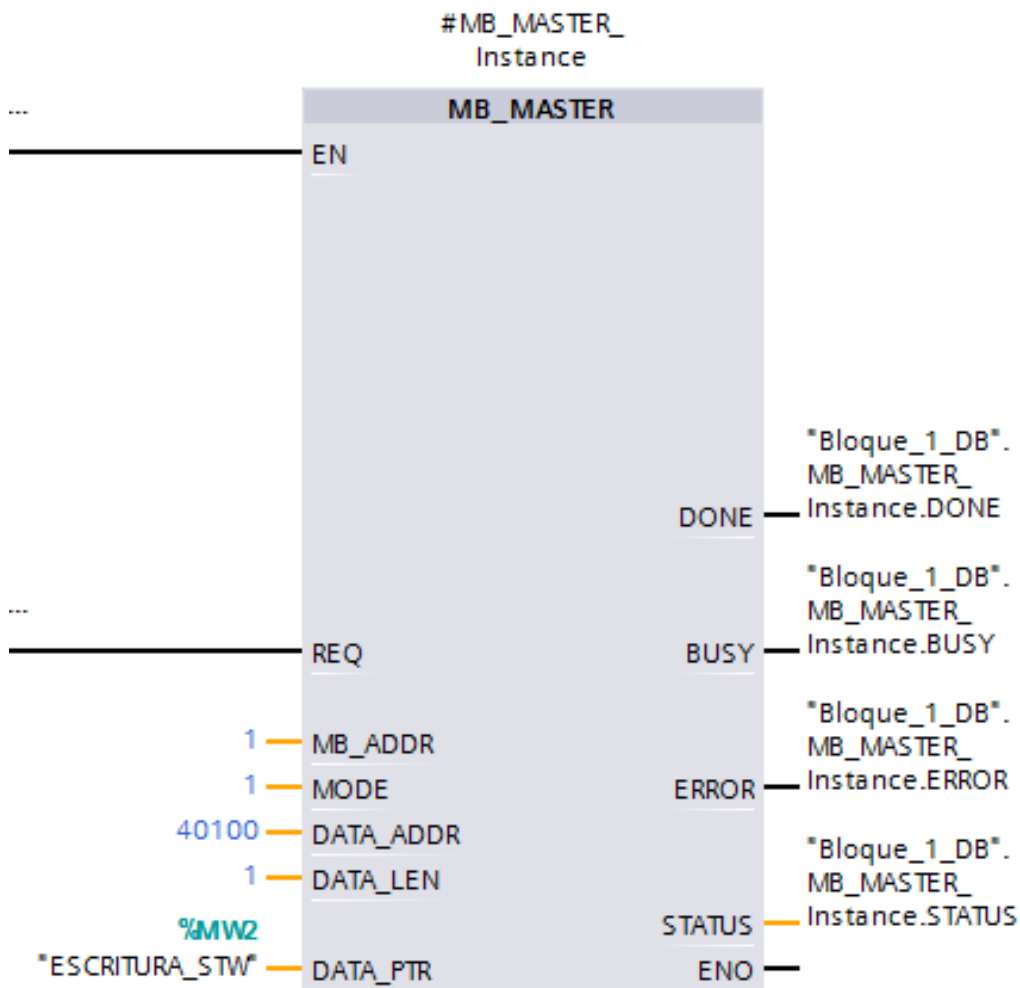

**Figura 2.10. Configuración del S7-1200 como Maestro**

Para comodidad y mayor control por parte del usuario se realizó una programación dividida por etapas. En el MAIN se ubicó los dos bloques que permitieron enviar datos usando el protocolo Modbus y además en el MAIN se llamó a las funciones

Palabra de Mando y Consigna de Velocidad. Se creó cada una de las funciones con la finalidad de tener mayor control al poder enviar la trama bit a bit.

A continuación, se presenta un ejemplo acerca de bloque de Palabra de mando:

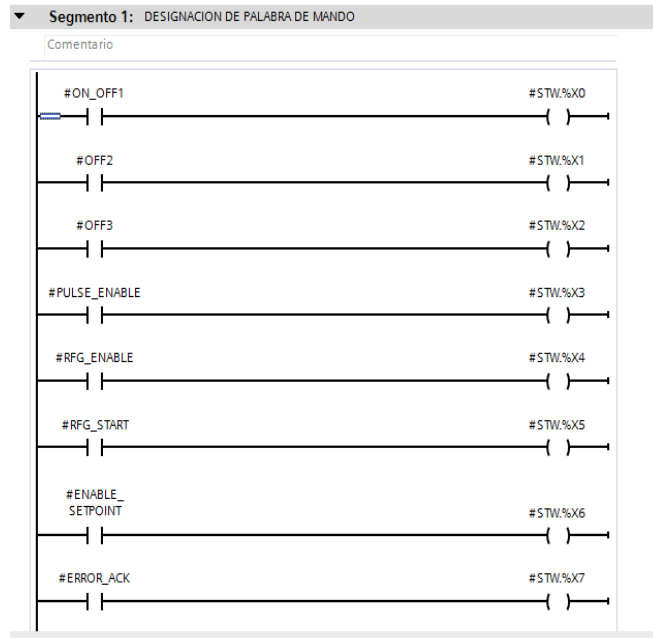

**Figura 2.11. Programación de Palabra de mando del V20**

Esta es la función palabra de mando, ésta permitió tener un control bit a bit. Existen bits que deben estar en alto por defecto como lo es PULSE\_ENABLE, RFG\_ENABLE, RFG\_START, ENABLE\_SETPOINT, a estos bits uno los declara como entrada, sin embargo, a los bits ON\_OFF, REVERSE, se la declara como entrada/salida de esta forma al llamar a la función desde el MAIN se obtiene un bloque de la siguiente forma:



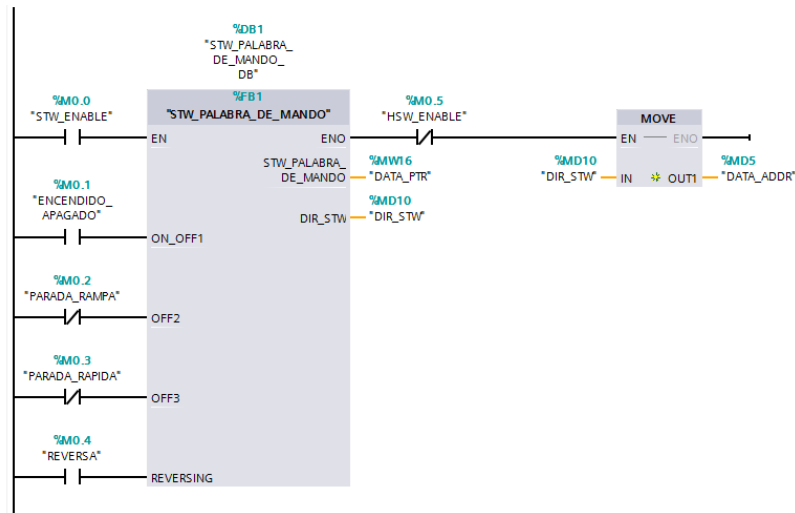

**Figura 2.12. Bloque de función de la palabra de mando**

## 2.7 Comunicación S7-1200 y ABB ACS355 VFD

Inicialmente se configuró los parámetros del variador ABB ACS355, que correspondieron a una secuencia básica de acciones que permitió insertar los datos del motor.

Estos parámetros fueron los siguientes:

**Tabla 2.9. Parámetros de datos del motor en el variador ACS355**

<b>9905</b>	Tensión Nominal
<b>9906</b>	Corriente Nominal
<b>9909</b>	Potencia Nominal
<b>9907</b>	Frecuencia Nominal
<b>9908</b>	Velocidad Nominal

Luego se configuró los parámetros para la comunicación entre el variador ABB ACS355 y el Módulo Adaptador MODBUS RTU FMBA-01. Con este módulo el variador pudo recibir cualquier trama bien configurada que use el mismo protocolo. Estos parámetros fueron los siguientes:

**Tabla 2.10. Parámetros de comunicación del variador ACS355**

9802	Sel Prot Com	1
5302	ID Estacion BCI	2
5303	Vel Transm BCI	9600
5304	Paridad BCI	2
5305	Perfil CTRL BCI	1

Una vez configurado completamente el variador ABB ACS355 se procedió a comunicar el variador con el PLC por medio del módulo de comunicación del S7-1200.

Para ello primero se configuró el módulo 1241 indicando la velocidad de transmisión, paridad, bit de datos, bit de parada, control de flujo y la IP que se le asignó.

Como el protocolo de comunicación a usar fue Modbus, hay que tener claro el uso de los bloques M\_MASTER y M\_COMM\_LOAD.

En dichos bloques se envió la trama de comunicación. Esta trama de ocho bits puede contener: palabra de mando, consigna de velocidad, palabra de estado y velocidad real.

**Tabla 2.11: Direcciones Modbus de Palabra de mando y velocidad ACS355**

	Parámetro	Dirección
STW	Código de control	40002
HSW	Referencia de Velocidad	40031

Para comodidad y mayor control por parte del usuario se realizó una programación dividida por etapas. En el MAIN se ubicó los dos bloques que permitieron enviar datos usando el protocolo Modbus y también en el MAIN se llamó a las funciones Palabra de Mando y Consigna de Velocidad. Se creó cada una de las funciones con la finalidad de tener mayor control al poder enviar la trama bit a bit.

A continuación, se presenta un ejemplo acerca de bloque de Consigna de Velocidad:

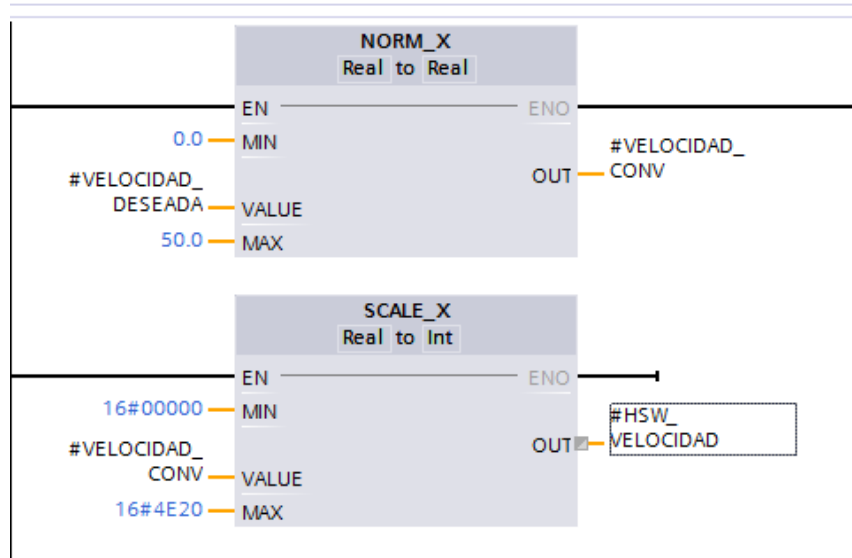

**Figura 2.13. Programación de velocidad del variador ACS355**

Esta función permitió escribir la velocidad a la cual se deseaba que el motor se mueva, para esto hay que tener en cuenta que el VFD ABB recibió como velocidad valores hexadecimales entre 0 a 4E20 entonces para mayor comodidad del usuario se realizó primero una normalización. Este bloque permitió llevar la velocidad que se deseaba a un valor entre 0 y 1, posteriormente el bloque de escalamiento permitió tomar ese valor entre 0 y 1 y transformarlo a un hexadecimal proporcional al valor de la velocidad deseado.

Una vez que se realizó la asignación al dato, se debía indicar a que dirección va el dato.

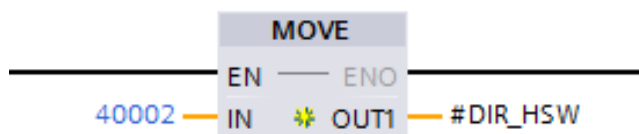

**Figura 2.14. Dirección de referencia de frecuencia del motor**

Finalmente se llamó a la función Consigna de Velocidad al Main.



Figura 2.15. Función de velocidad del motor desde ACS355

## 2.8 Red Industrial

Para la parte de configuración de la red mostrada se realizó la configuración de la red desde la IP tomada del laboratorio de Electrónica de Potencia. Posteriormente se conectó un cable adaptador de red a un router, en el proyecto se utilizó un router TP-LINK. Ingresando se debía configurar varios parámetros para crear una subred. Posterior a la configuración de la red se configuraron las direcciones IP de cada elemento en la red. Se colocaron direcciones IP de forma estática para que no exista conflicto en la red.

Tabla 2.12. Direcciones IP de los equipos

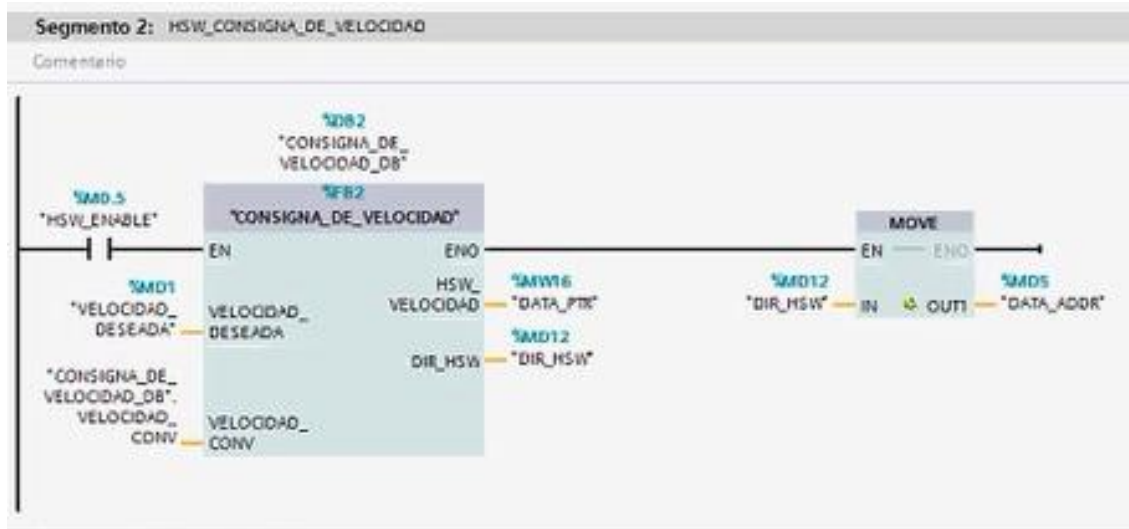
Dirección IP	Equipo
192.168.0.101	MICRO850
192.168.0.105	S7-1200
192.168.0.100	PC-Principal
192.168.0.110	PC-Secundaria

## LAN

**MAC Address:** 64-70-02-99-95-0C  
**IP Address:** 192.168.0.1  
**Subnet Mask:** 255.255.255.0

---

## Wireless

**Wireless Radio:** Enable  
**Name (SSID):** Integradora  
**Channel:** 1  
**Mode:** 11bgn mixed  
**Channel Width:** Automatic  
**Max Tx Rate:** 150Mbps  
**MAC Address:** 64-70-02-99-95-0C  
**WDS Status:** Disable

---

## WAN

**MAC Address:** 64-70-02-99-95-0D  
**IP Address:** 192.168.51.21      Static IP  
**Subnet Mask:** 255.255.255.128  
**Default Gateway:** 192.168.51.1  
**DNS Server:** 200.9.176.5 , 192.188.59.2

Figura 2.16. Parámetros de la red LAN y Wireless

A partir de esto se pudieron colocar las direcciones IP de los PLC en la DMZ para poder tener acceso a las variables del PLC de manera remota.

ID	Service Port	Internal Port	IP Address	Protocol	Status	Modify
1	23	23	192.168.0.101	TCP	Enabled	<a href="#">Modify</a> <a href="#">Delete</a>

**Figura 2.17. DMZ de los dispositivos de la red**

Se debe tener en cuenta que cuando se realiza un DMZ en los PLC se debe habilitar el acceso remoto en cada uno de ellos, dado que si no se activa no se podrá tener acceso a las variables del PLC. Por lo general son nodos a entradas de red o entradas de variables OPC.

## 2.9 Comunicación PLC y PC

Una vez formada la red entre los equipos se procederá a realizar una comunicación y parametrización de los datos vía OPC server. Para la configuración de OPC en el PLC S7-1200 se deberá activar en las propiedades del plc la opción de seguridad. Mientras tanto en el MICRO 850 se deberá realizar un mapeo de la variable para poder utilizarlas vía OPC.

## Controller - Modbus Mapping

	Variable Name	Data Type	Address	Addresses Used
▶	STW_ENABLE@MAIN	Bool	000001	000001
	HSW_ENABLE@MAIN	Bool	000002	000002
	ENCENDIDO_APAGADO...	Bool	000003	000003
	REVERSA@MAIN	Bool	000004	000004
	PARADA_RAMPA@MAIN	Bool	000005	000005
	VELOCIDAD@MAIN	Real	400001	400001 - 400002
*				

**Figura 2.18. Modbus Mapping de Variables Micro850**

Una vez establecido el mapeo de las variables y la habilitación de entradas de red se procede a configurar el OPC server.

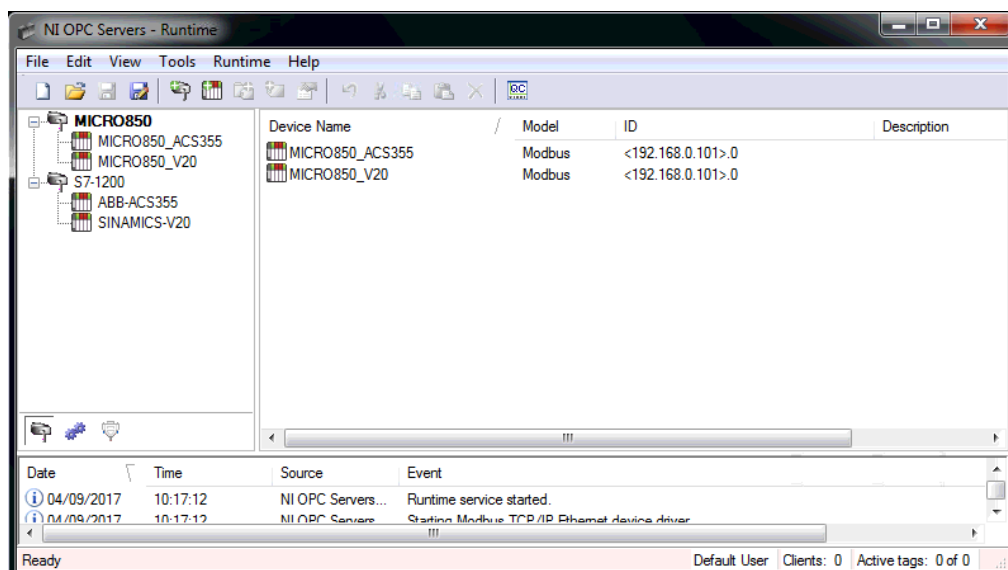

**Figura 2.19. OPC de MICRO850 y S7-1200**

Luego de crear los archivos OPC se comienza a declarar las variables de cada programación y las que se están utilizando.

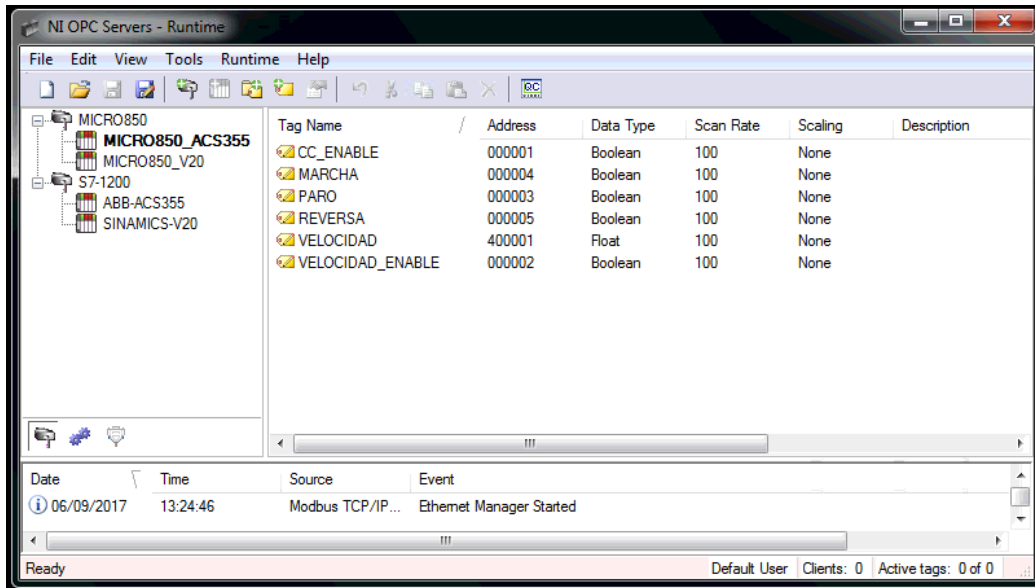

**Figura 2.20. Variables OPC MICRO850-ABB ACS355**

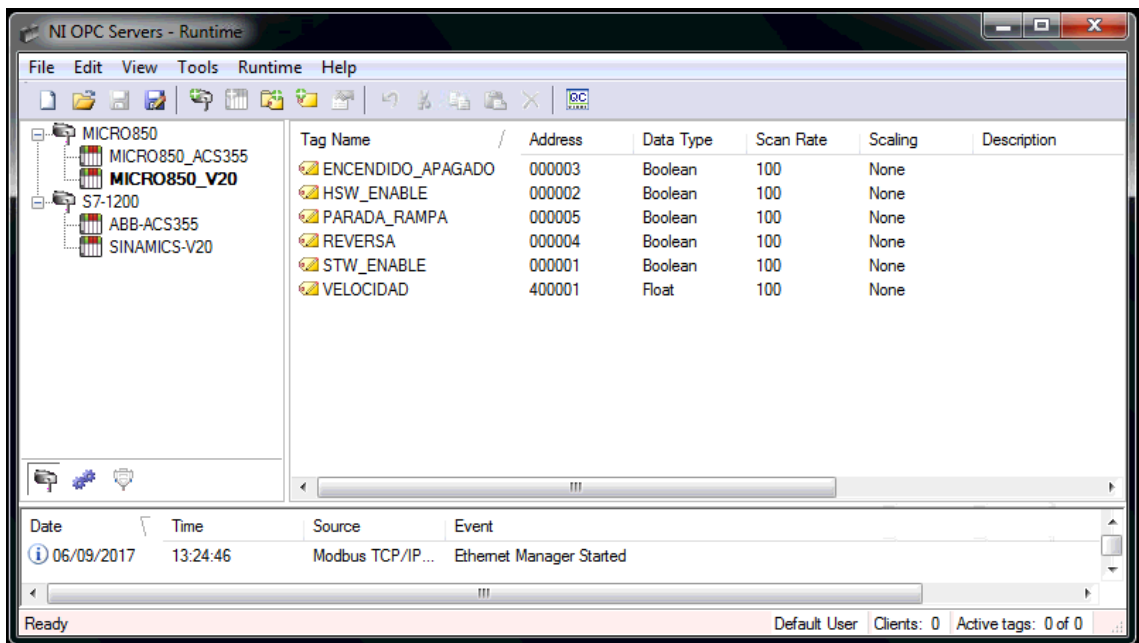

**Figura 2.21. Variables OPC MICRO850-V20**

De igual forma se crean las variables OPC se PLC S7-1200



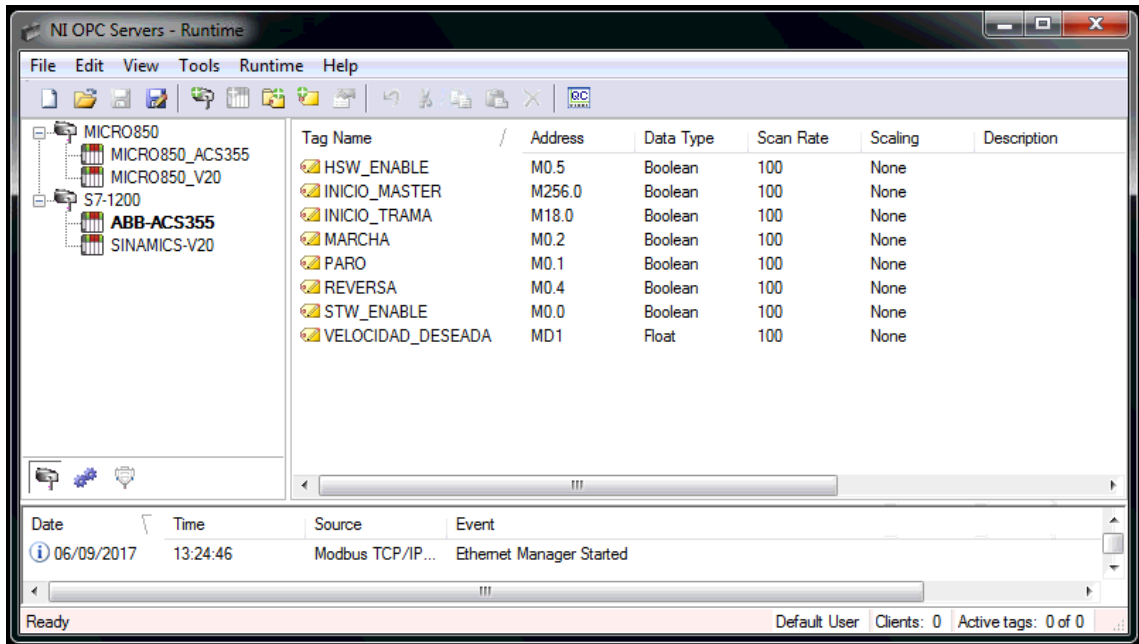

**Figura 2.22. Variables OPC S7-1200-ABB ACS355**

Por ultimo tenemos las variables de S7-1200 hacia el V20

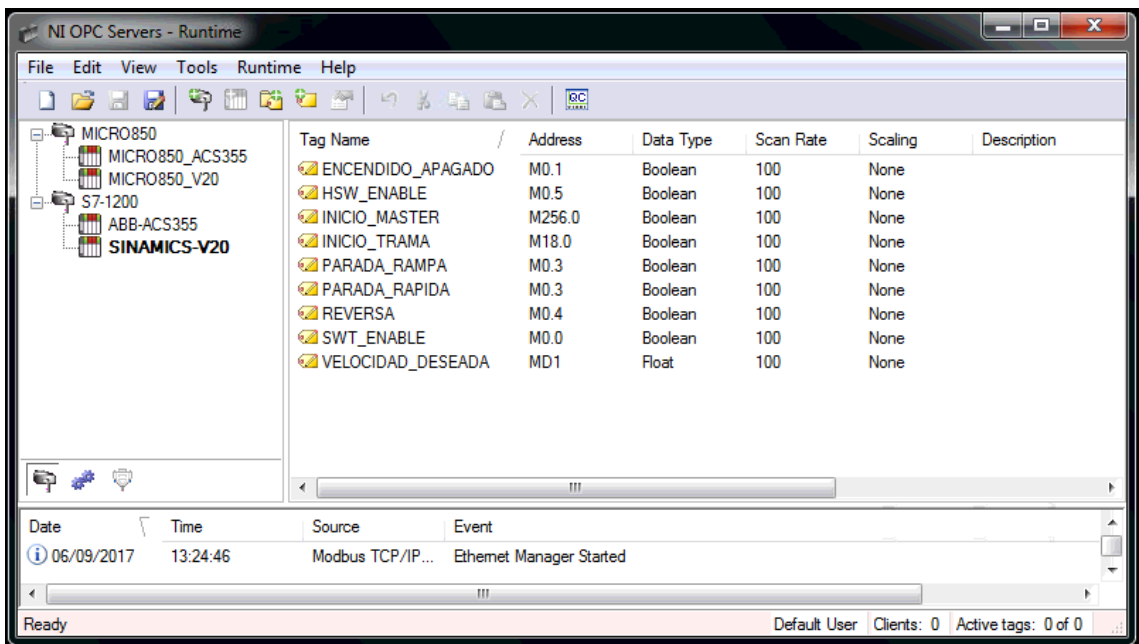

**Figura 2.23. Variables OPC S7-1200-V20**

## 2.10 SCADA

Se realizó el SCADA en Visual Studio, para este diseño se creó:

Una página principal que contiene: página de inicio, acerca del proyecto y contactos.

Cuatro Project tipo forms en cual se programó la emigración de datos desde NI OPC a VB.

La página principal fue programada en C#, en donde se usaron los siguientes comandos:

Jumbotron text-center

```
<div class="jumbotron text-center">
  <h2>ESCUELA
SUPERIOR POLITECNICA DEL LITORAL</h2>
  <h2>Facultad de Ingenieria en Electricidad y Computacion</h2>
  <p class="lead">Diseño e implementación de una red Modbus
utilizando PLC's y VFD's de tecnología Siemens, Allen Bradley y
ABB.</p>
</div>
```

**Figura 2.24. Jumbotron text-center**

Permite centrar un texto en la parte superior de la página web de esa forma se colocó el encabezado, teniendo el siguiente resultado.



**Figura 2.25. Portada Pagina Web**

Posteriormente se procedió a colocar las imágenes del PLC S7-1200 y del MICRO850 con su respectivo botón.

```

|
<div class="row">
  <div class="col-md-6">
    <h2>SIEMENS S7-1200</h2>
    <p>
      Aqui tendremos la comunicacion con los VFD's: V20 y
    </p>
    <p>
      
    </p>
    <p ALIGN=center>
      <a class="btn btn-primary" href="S71200.aspx">Conectar S7-1200</a>
    </p>
  </div>
  <div class="col-md-6">
    <h2>MICRO 850</h2>
    <p>
      Aqui tendremos la comunicacion con los VFD's: V20 y ACS355
    </p>
    <p>
      
    </p>
    <p ALIGN=center>
      <a class="btn btn-primary" href="MICRO850.aspx">Conectar micro485
    </a>
  </div>
</div>

```

Permite dividir la página en dos partes iguales

Programación de un botón primario, al ser presionado irá a la página MICRO850

**Figura 2.26. Programación de Botones de interacción**

Teniendo en el ejecutable el siguiente resultado.



**Figura 2.27: Pantalla Principal con los PLC's**

De la misma forma se procedió a programar cada sección de la página principal. Una vez que se programó la página principal se procedió a programar la emigración de datos. Para aquello se creó para cada comunicación un form, esto quiere decir que se creó una página para cada comunicación.

# CAPÍTULO 3

## 3. RESULTADOS Y ANÁLISIS

En el presente capítulo se analizan los resultados obtenidos a lo largo del proyecto, indicando su factibilidad y realizando un análisis de costos de todo el proyecto para conocer su rentabilidad.

Para estos análisis es necesario reconocer el estado inicial del proyecto, como estaba inicialmente y como se encuentra actualmente. El proyecto se encontraba en nivel de acceso dos, es decir, los variadores eran controlados por el display propio del VFD's. Actualmente los VFD's son controlados por un computador de forma remota asignándole una IP a cada PLC, esto quiere decir que el variador está en un nivel de acceso 3 o avanzado. Además, la elección del protocolo es un tema a considerar debido a que se puede implementar en distancias considerablemente extensas ventaja que no todos los protocolos tienen. El costo a invertir en software es relativamente bajo debido a que NIOPC es el único programa en el que se debe invertir y Visual Studio es libre.

Por tema de rentabilidad este proyecto resulta ser beneficioso para aquellas industrias que recién empiezan a invertir en procesos industriales de manufactura, debido a que pueden integrar equipos industriales no tan costosos sin fijarse en el fabricante. No sucede de la misma manera con industrias multinacionales muy conocidas en el medio debido a que cuentan con demandas de equipos industriales altas y por ende tienen un precio bajo al trabajar con el distribuidor principal que no siempre suele ser nacional sino internacional, lo que resulta en productos importados.

Finalmente, comparando trabajos realizados en otras universidades han tenido como resultados la comunicación entre S7-1200 y SINAMICS V\_20 sin SCADA. Sin embargo, dicha información de estudio fue valiosa para lograr entrelazarlo con nuestro proyecto integrador, pues por medio esta investigación realizada por la ESPE titulada por diseño e implementación de un sistema de entrenamiento en redes industriales utilizando tecnología siemens se pudo comunicar el mismo PLC

S7-1200 con el VFD ABB ACS 355 logrando la independencia de marcas y a su vez comprendido que la programación es por bloque y de forma cíclica se pudo realizar la analogía con el otro PLC MICRO 850.

### 3.1 Análisis de Presupuesto

A continuación, se presenta la inversión realizada por parte del Laboratorio de Electrónica de Potencia de ESPOL.

En la lista de precios no se considera el computador donde se realizó la programación, el motor de inducción tampoco se lo consideró dado que es la carga del sistema y la universidad lo facilita para las pruebas con los diversos variadores. De esta forma se reduce la inversión por parte del grupo de trabajo, aunque es importante tener en cuenta aquellos materiales no considerados debido a que representan un precio sustancial al momento de elaborar el proyecto integrador.

Se debe considerar que estos precios fueron obtenidos en el mes de agosto del 2017 los costos pueden fluctuar en años posteriores.

**Tabla 3.1. Detalles de lista de materiales y precios**

Cantidad	Nombre	Descripción	Costo
<b>HARDWARE</b>			
1	Sinamics Siemens V20 VFD	Variador de Velocidad Motor de Inducción	\$ 292,00
1	ABB ACS355 MACHINERY VFD	Variador de Velocidad Motor de Inducción	\$ 240,24
1	Simatic Siemens S7-1200 AC/DC/Rly	Controlador Lógico Programable	\$ 497,00
1	Allen Bradley Micro 850 24QBB	Controlador Lógico Programable	\$ 250,00
1	CM1241 RS232	Módulo Modbus RS232	\$ 270,00
1	Módulo 2080 SERIALISOL	Módulo de Comunicación serial	\$ 46,80
1	FMBA01/ABB	Módulo Modbus RS485	\$ 182,78
1	ADAM 4520	Convertidor RS232 a RS485/RS422	\$ 65,00
1	Router TP-LINK N-150Mbps	Router para PC y PLC	\$ 18,00
<b>SOFTWARE</b>			
1	TIA PORTAL	Programador de PLC S7-1200	\$ 700,00
1	Connected Components Workbench	Programador de Micro 850	\$ -
1	Eltima Serial Port	Lector de trama Modbus a la PC	\$ -
<b>Costo Total</b>			<b>\$ 2.561,82</b>

El costo actual en lo que respecta a mano de obra se debe de considerar un ingeniero como integrador del proyecto un maestro y un oficial. El ingeniero tiene un costo diario de \$70 un maestro \$35, es decir, que en lo que respecta a mano de obra tenemos un consumo de \$105 diarios si el proyecto se toma 10 días laborables tenemos un costo de mano de obra de \$1050.

Todo lo considerado son costos ahora poniéndole una utilidad del 15% el proyecto tiene un precio al cliente de \$4153.60 + IVA.

Se consideró utilizar tanto el variador Sinamics V20 y el variador ABB ACS355 dado que los dos utilizan el mismo protocolo de comunicación MODBUS RTU con interfaz eléctrica RS-485.

El S7-1200 utiliza un módulo de comunicación Modbus RTU con salidas RS232 para comunicarse con el variador.

Con respecto al Micro850 se comunica con los variadores mediante el módulo SERIALISOL dado que este tiene salidas RS322 y también RS485.

El Router es utilizado para repartir IP a los diferentes dispositivos además sirvió como enlace de las variables del PLC hacia el servidor web.

Este sistema puede ser implementado en industrias que requieran que el usuario no esté en contacto con el proceso, es decir, que el sistema puede ser controlado desde una oficina aislada a la planta. A su vez este sistema también puede ser utilizado para que el proceso se comprenda de una manera simple y sencilla, debido a que en el SCADA no se topa con lenguajes de programación o parámetros complejos a cambiar, sino que podrá observar y cambiar las variables que desee a tiempo real.

De esta forma se podría realizar un análisis estadístico, acerca de cómo está la eficiencia del proceso, también se puede obtener un ahorro en el tiempo al no necesitar personal que tome los datos del proceso debido a que los datos lo obtendríamos por medio del SCADA.

### **3.2 Resultados obtenidos**

En la actualidad al comunicar diversos dispositivos se debe establecer un mismo protocolo de comunicación, en este proyecto el protocolo de comunicación fue el de Modbus RTU y Modbus TCP/IP.



**Figura 3.1. Panel de Variador Siemens V-20**

En los resultados obtenidos con respecto al variador Sinamics Siemens V-20, se pudo establecer que la transferencia de datos debe ser de forma cíclica, es decir, repetir el mismo proceso para poder enviar una orden al variador.

Este variador se comunicó con dos PLC: el S7-1200 y con el micro850 de ALLEN BRADLEY. En ambos casos es importante llevar la misma interfaz eléctrica, debido a que inicialmente se intentó comunicar el S7-1200 con el módulo de comunicación 1241 RS232 y se usó un convertidor de 232 a 485 para de esta forma lograr la comunicación sin embargo esto no pudo lograrse y existió la necesidad de adquirir el módulo de comunicación 1241 RS422/485. De esta forma la trama fue enviada correctamente, no hubo errores debido a que la interfaz eléctrica usada fue la misma. Este módulo de comunicación fue programado para usarlo de forma Semiduplex debido a que el PLC actuó como maestro y los VFD como esclavo, es decir, únicamente existe un equipo que envía la trama y existe otro equipo que es quien recibe la trama.

A diferencia del micro850 que su módulo de comunicación llamado SERIALISOL tenía una interfaz eléctrica 232 a 485, entonces en lo que respecta a la interfaz eléctrica la comunicación más rápida fue la del micro850, sin embargo, para el micro850 se realizó la conversión respectiva para poder enviar correctamente la trama. Esta conversión fue necesaria caso contrario la palabra que se envíe no será la que se desea.

Al momento de ejecutar la comunicación entre el ABB ACS355 y el PLC Micro 850 se realizó la conexión del EIA-485 la cual está diseñada para aplicaciones multipunto (un solo maestro controla uno o más esclavos).



**Figura 3.2. Conexión entre Micro850 y ACS355**

Una vez realizadas las conexiones y su comunicación se tuvieron que considerar que el fabricante del variador indica que existen varios perfiles de maestros que pueden controlar el variador, los cuales son ABB Basic, ABB Advanced, DCU.

Dado que el controlador es de la marca Allen Bradley el perfil utilizado es el DCU el cual permitió controlar el variador de frecuencia de forma remota desde el PLC.

La forma de transferir los parámetros se lo analiza en el siguiente diagrama:



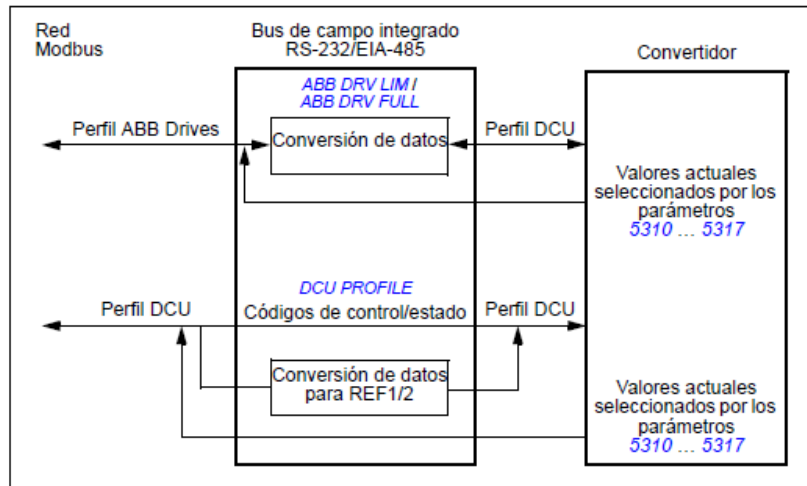

**Figura 3.3. Perfiles de comunicación en el Variador ACS355**

De la misma forma se realizó la comunicación entre el Variador ACS355 y el PLC S7-1200. Existió la necesidad de usar el perfil DCU el cual permitió controlar el variador de forma remota desde el PLC.

Para emigrar los datos del software de los PLC a una dirección de la PC se aplicó OLE Process Control usando el programa OPC de la National Instrument. Posteriormente la emigración de datos se la realizó mediante un DDL desde el servidor OPC a Visual, mostrando así otra alternativa para la realización de un sistema SCADA.

En este proyecto se usó como software para el servidor web el programa VISUAL STUDIO 2013, punto a tener en cuenta debido a que no se ha encontrado anteriormente un servidor web que pueda controlar a algún variador vía protocolo Modbus realizando programación orientada a objetos.

Finalmente se puede decir que se obtuvo un nivel de acceso 3 o avanzado porque anteriormente estos VFD's eran controlados por medio de su wiring diagram control, ahora estos VFD's son controlados por un controlador.

Un punto a tener en cuenta es que no hemos encontrado anteriormente un servidor web que pueda controlar a algún variador vía protocolo Modbus.

En este proyecto usamos como software para el servidor web el programa VISUAL STUDIO 2015, y aunque a pesar de que no se contaba con la preparación necesaria para implementar el SCADA en esta plataforma se asumió el reto y se obtuvieron los siguientes resultados.



ESCUELA SUPERIOR POLITECNICA DEL LITORAL

Facultad de Ingeniería en Electricidad y Computación

Diseño e implementación de una red Modbus utilizando PLC's y VFD's de tecnología Siemens, Allen Bradley y ABB.

**SIEMENS S7-1200**

Aquí tendremos la comunicación con los VFD's: V20 y ACS355

**MICRO 850**

Aquí tendremos la comunicación con los VFD's: V20 y ACS355

**Figura 3.4. Pantalla principal del SCADA**

En esta pantalla principal se presenta el tema de proyecto de integración y también los elementos maestros a usar.

Este servidor web no solo cuenta con su comunicación industrial, sino que cuenta también con una estética alta para una óptima presentación, agregando agradecimiento y contactos.

# CAPÍTULO 4

## 4. CONCLUSIONES Y RECOMENDACIONES

En este capítulo se presentan las conclusiones del proyecto integrador, siguiendo las pautas que han guiado la presentación de los resultados, es decir, se muestran las conclusiones sobre los resultados cualitativos y cuantitativos de la implementación realizada.

Dicha implementación muestra que no es indispensable que los equipos PLC & VFD sean de la misma marca, sino que a través del protocolo Modbus RTU y TCP/IP se puede comunicar cualquier equipo sin restricción de marca a diferencia de proyectos anteriores ya citados que comunican dispositivos del mismo fabricante.

Al considerar los diversos protocolos de comunicación para la elaboración de este proyecto integrador se partió de la idea de cubrir las necesidades industriales que se generan hoy en día, entre ellas el controlar la mayor cantidad de motores que se encuentren en la planta de manera remota sin necesidad que encontrarse en el mismo sitio del motor.

Sin duda, la presente implementación involucra un estudio minucioso acerca de los niveles de acceso y palabras de mando para la comunicación. Para una futura mejora se podría implementar un PID en los motores que permita cerrar el lazo de control de esta forma se automatizaría con mayor eficacia las velocidades del equipo.

### Conclusiones

Para el presente proyecto se puede dar las siguientes conclusiones:

Se implementó una Red Modbus esta comunicación puede ser RTU o TCP/IP la diferencia que existe entre ambas es que la TCP/IP permite realizar configuraciones de forma externa desde un dispositivo remoto o lejano a la red. En lo que respecta a la interfaz eléctrica esta puede ser RS232 y RS485 su diferencia es el alcance que se puede tener entre equipos. Además, la interfaz RS232 es una conexión punto a punto, es decir solo se puede transmitir información a un solo equipo. La

interfaz eléctrica RS485 puede tener más de un dispositivo en la red a la cual transmitir. Por tal motivo se puede decir que mayor relevancia tiene RS485, dicha interfaz permite controlar a más de un motor a la vez.

Se manipuló de forma parcial las variables del SCADA usando VISUAL BASIC.NET 2013 debido a que esta versión cuenta con las librerías para emigrar los datos desde el OPC a VISUAL, esta programación se la realizó en C++, sin embargo, la pantalla principal de la Web se la programo en C#. En los VFD's se programó los datos de placa del motor a usar, habilitando el cambio de giro en su respectivo parámetro, de esa forma se evita la carga de los datos de placa del motor cada vez que se encienda el VFD. El lenguaje de programación a usar es indistinto siempre y cuando se comprenda los comandos a usar, se realizó la programación tanto con C# y con C++ para demostrar que ambos lenguajes pueden llegar a implementarse.

Se pudo concluir que la tasa de trasmisión de los bits debe estar sincronizados para que los errores de comunicación por error de redundancia cíclica no ocurran.

Se concluyó que los protocolos de comunicación basados en PLC y VFD'S no se basan en marcas específicas sino de normas establecidas entre diversos fabricantes para el mejor funcionamiento e integración de varios sistemas.

El protocolo de comunicación Modbus se puede utilizar ya sea en su modo básico RTU o en su modo actual TCP-IP. Este último facilita la integración de sistemas de supervisión remotos asignándole una IP diferente a cada PLC. De esta forma se puede controlar remotamente los autómatas brindando una independencia de estar permanentemente en un cuarto de maniobras, sino que sin importar el lugar en donde uno se encuentre se puede mantener la comunicación realizada.

Además, los sistemas de supervisión basados en diversos fabricantes ayudarían a disminuir costos de proyectos, a industrias que recién se encuentren iniciando debido a que no deben buscar marcas con renombre para montar una planta completa, sino que según su presupuesto se utilizarían equipos eficientes, atractivos económicamente y comunicarlos entre sí para formar una planta industrial de manufactura nueva.

Basados en los equipos siemens S7-1200 y el variador siemens v20 se concluyó que dadas que son equipos del mismo fabricante las limitaciones de los protocolos

se disminuyen dado que el mismo software del fabricante ayuda a la manipulación de la trama, es decir posee una programación más sencilla y además ambas tienen la facilidad de transmitir datos a mayores velocidades superando fácilmente los 19600 baudios.

En los equipos siemens S7-1200 y el variador ABB ACS355 la comunicación se debe realizar de forma más detallada indicando absolutamente todos los parámetros de transmisión tales como interfaz eléctrica, protocolo de comunicación, direcciones de memoria, tamaño de la trama, paridad de la trama y error de redundancia cíclica.

Además, en los equipos micro 850 y el variador siemens v20 se concluyó que si se puede realizar una comunicación teniendo en cuenta las tasas de transmisiones de datos y el error de redundancia de datos para que se transmita de forma correcta la trama.

Finalmente, con los equipos micro 850 y el variador ABB ACS355 se concluyó que se debe realizar los mismos lineamientos anteriores para poder configurar absolutamente todos los bits de la palabra de mando y la palabra de control del variador de velocidad.

#### **4.1 Recomendaciones**

Cuando se realice la comunicación y se utiliza la interfaz eléctrica RS485 con más de un esclavo en la red se deben utilizar las resistencias de terminación.

Cuando se utilice el puerto integrado Modbus del variador ACS355 se debe colocar el modo remoto para que pueda recibir la palabra de mando desde el PLC.

Procurar utilizar cable Profibus para las conexiones dado que tienen menor resistencia y generar una caída de voltaje menor a la de un cable convencional.

Utilizar el módulo CM1241 RS485 con el PLC S7-1200 para la comunicación entre el variador ACS355 y el módulo FMBA01 puesto que si se utiliza el puerto integrado del variador se puede dañar la pantalla BOP cada vez que se procede a retirarla.

Utilizar el programa NI OPC Server para poder establecer una comunicación ininterrumpida entre el variador y el PLC, dado que no se puede perder la comunicación cuando el motor este encendido porque puede quedar girando sin ningún control del operador.

Es recomendable utilizar la velocidad de transmisión de 9600 baudios para la transmisión de datos, se debe configurar esta velocidad en el PLC y el variador.

Se sugiere que previo a la transmisión de datos utilice un software que el permita visualizar que palabra de mando está enviando, esto le optimizará el tiempo y a su vez podrá reconocer en que bit está fallando exactamente

Es recomendable leer primeramente sobre los manuales de los equipos para disminuir los tiempos de programación de los autómatas.

Use terminales de punta número 18 para realizar un buen contacto en las borneras de esta forma evita que se genere algún corto y asegura la continuidad en el circuito.

# BIBLIOGRAFÍA

- [1] Siemens AG 2009 Industry NÜRNBERG ALEMANIA , «<https://w5.siemens.com>,» Octubre 2009. [En línea]. Available: <https://w5.siemens.com/spain/web/es/industry/automatizacion/simatic/Documents/S71200-MANUAL%20DEL%20SISTEMA.PDF>.
- [2] SIMATIC S7-1200 Sector Industria, «<https://w5.siemens.com>,» [En línea]. Available: [https://w5.siemens.com/spain/web/es/industry/automatizacion/sce\\_educacion/Documentacion-Didactica/Documents/SIMATIC%20S71200R.pdf](https://w5.siemens.com/spain/web/es/industry/automatizacion/sce_educacion/Documentacion-Didactica/Documents/SIMATIC%20S71200R.pdf). [Último acceso: 14 Junio 2017].
- [3] Rockwell Automation 2080-UM002G-ES-E , «<http://literature.rockwellautomation.com>,» Marzo 2015. [En línea]. Available: [http://literature.rockwellautomation.com/idc/groups/literature/documents/um/2080-um002\\_-es-e.pdf](http://literature.rockwellautomation.com/idc/groups/literature/documents/um/2080-um002_-es-e.pdf). [Último acceso: 14 Junio 2017].
- [4] Siemens AG 2012 - 2013, «<https://cache.industry.siemens.com>,» Febrero 2013. [En línea]. Available: [https://cache.industry.siemens.com/dl/files/484/67267484/att\\_61462/v1/v20\\_OPI\\_es-SP\\_es-ES.pdf](https://cache.industry.siemens.com/dl/files/484/67267484/att_61462/v1/v20_OPI_es-SP_es-ES.pdf). [Último acceso: 14 Junio 2017].
- [5] 2015 ABB Oy, «<https://library.e.abb.com>,» 30 Abril 2015. [En línea]. Available: [https://library.e.abb.com/public/22ccf851ed8b4aa885f451ae44e895ac/ES\\_ACS355\\_UM\\_C\\_A5.pdf](https://library.e.abb.com/public/22ccf851ed8b4aa885f451ae44e895ac/ES_ACS355_UM_C_A5.pdf). [Último acceso: 14 Junio 2017].
- [6] A. A. JARAMILLO MATTA, E. FRANCO MEJÍA y L. GUASCH PESQUER, «<http://search.proquest.com>,» Octubre 2011. [En línea]. Available: <http://search.proquest.com/docview/1677483524?pq-origsite=gscholar>. [Último acceso: 14 Junio 2017].
- [7] SIEMENS, «Siemens Support Automation,» Noviembre 2014. [En línea]. Available: <http://support.automation.siemens.com/WW/view/en/63696870>. [Último acceso: 10 5 2017].

- [8] C. S. Siskind, "Sistemas de Control Eléctrico en la Industria", McGraw-Hill., 2015.
- [9] L. Zheng y H. Nakagawa, «IEEE Xplore,» 29 Abril 2003. [En línea]. Available: <http://ieeexplore.ieee.org/abstract/document/1195286/>. [Último acceso: 13 Junio 2017].
- [10] MODBUS ORG, «Comunicación Modbus,» Agosto 2012. [En línea]. Available: <http://www.Modbus.org/>. [Último acceso: 14 Junio 2017].
- [11] MODBUS ORG, «Modbus TCP/IP,» 2006 Octubre 2006. [En línea]. Available: <http://www.modbus-ida.org/>. [Último acceso: 14 Junio 2017].
- [12] SIEMENS, «STEP7-SIMATIC S7-1200,» 11 2014. [En línea]. Available: <http://support.automation.siemens.com/WW/view/en /91696622>. [Último acceso: 20 5 2017].
- [13] National Instruments, «National Instruments,» 13 Abril 2017. [En línea]. Available: <http://www.ni.com/white-paper/13865/en/>. [Último acceso: 13 Junio 2017].



# **ANEXOS**

## **ANEXO A**

### **Programación del Micro 850 – Sinamics V20**

## Configuration Micro850

The detailed description of the configuration goes here

## Resource Micro850

(\* \*)

Status:       Readable, Modifiable, Deletable

The resource defines 45 variable(s).

### Variable \_IO\_EM\_DO\_00

(\* \*)

Direction:       VarDirectlyRepresented

Data type:        BOOL

Attribute:        Read/Write

Direct variable (Channel): %QX0.0.0

### Variable \_IO\_EM\_DO\_01

(\* \*)

Direction:       VarDirectlyRepresented

Data type:        BOOL

Attribute:        Read/Write

Direct variable (Channel): %QX0.0.1

### Variable \_IO\_EM\_DO\_02

(\* \*)

Direction:       VarDirectlyRepresented

Data type:        BOOL

Attribute:        Read/Write

Direct variable (Channel): %QX0.0.2

### Variable \_IO\_EM\_DO\_03

(\* \*)

Direction:       VarDirectlyRepresented

Data type:        BOOL

Attribute:        Read/Write

Direct variable (Channel): %QX0.0.3

### Variable \_IO\_EM\_DO\_04

(\* \*)

Direction:       VarDirectlyRepresented

Data type:        BOOL

Attribute:        Read/Write

Direct variable (Channel): %QX0.0.4

### **Variable \_IO\_EM\_DO\_05**

(\* \*)

Direction: VarDirectlyRepresented  
Data type: BOOL  
Attribute: Read/Write  
Direct variable (Channel): %QX0.0.5

### **Variable \_IO\_EM\_DO\_06**

(\* \*)

Direction: VarDirectlyRepresented  
Data type: BOOL  
Attribute: Read/Write  
Direct variable (Channel): %QX0.0.6

### **Variable \_IO\_EM\_DO\_07**

(\* \*)

Direction: VarDirectlyRepresented  
Data type: BOOL  
Attribute: Read/Write  
Direct variable (Channel): %QX0.0.7

### **Variable \_IO\_EM\_DO\_08**

(\* \*)

Direction: VarDirectlyRepresented  
Data type: BOOL  
Attribute: Read/Write  
Direct variable (Channel): %QX0.0.8

### **Variable \_IO\_EM\_DO\_09**

(\* \*)

Direction: VarDirectlyRepresented  
Data type: BOOL  
Attribute: Read/Write  
Direct variable (Channel): %QX0.0.9

### **Variable \_IO\_EM\_DI\_00**

(\* \*)

Direction: VarDirectlyRepresented  
Data type: BOOL  
Attribute: Read  
Direct variable (Channel): %IX0.1.0

### **Variable \_IO\_EM\_DI\_01**

(\* \*)

Direction: VarDirectlyRepresented  
Data type: BOOL

Attribute: Read  
Direct variable (Channel): %IX0.1.1

### **Variable \_IO\_EM\_DI\_02**

(\* \*)  
Direction: VarDirectlyRepresented  
Data type: BOOL  
Attribute: Read  
Direct variable (Channel): %IX0.1.2

### **Variable \_IO\_EM\_DI\_03**

(\* \*)  
Direction: VarDirectlyRepresented  
Data type: BOOL  
Attribute: Read  
Direct variable (Channel): %IX0.1.3

### **Variable \_IO\_EM\_DI\_04**

(\* \*)  
Direction: VarDirectlyRepresented  
Data type: BOOL  
Attribute: Read  
Direct variable (Channel): %IX0.1.4

### **Variable \_IO\_EM\_DI\_05**

(\* \*)  
Direction: VarDirectlyRepresented  
Data type: BOOL  
Attribute: Read  
Direct variable (Channel): %IX0.1.5

### **Variable \_IO\_EM\_DI\_06**

(\* \*)  
Direction: VarDirectlyRepresented  
Data type: BOOL  
Attribute: Read  
Direct variable (Channel): %IX0.1.6

### **Variable \_IO\_EM\_DI\_07**

(\* \*)  
Direction: VarDirectlyRepresented  
Data type: BOOL  
Attribute: Read  
Direct variable (Channel): %IX0.1.7

### **Variable \_IO\_EM\_DI\_08**

(\* \*)

Direction: VarDirectlyRepresented  
Data type: BOOL  
Attribute: Read  
Direct variable (Channel): %IX0.1.8

### **Variable \_IO\_EM\_DI\_09**

(\* \*)

Direction: VarDirectlyRepresented  
Data type: BOOL  
Attribute: Read  
Direct variable (Channel): %IX0.1.9

### **Variable \_IO\_EM\_DI\_10**

(\* \*)

Direction: VarDirectlyRepresented  
Data type: BOOL  
Attribute: Read  
Direct variable (Channel): %IX0.1.10

### **Variable \_IO\_EM\_DI\_11**

(\* \*)

Direction: VarDirectlyRepresented  
Data type: BOOL  
Attribute: Read  
Direct variable (Channel): %IX0.1.11

### **Variable \_IO\_EM\_DI\_12**

(\* \*)

Direction: VarDirectlyRepresented  
Data type: BOOL  
Attribute: Read  
Direct variable (Channel): %IX0.1.12

### **Variable \_IO\_EM\_DI\_13**

(\* \*)

Direction: VarDirectlyRepresented  
Data type: BOOL  
Attribute: Read  
Direct variable (Channel): %IX0.1.13

### **Variable \_\_SYSVA\_CYCLECNT**

(\* Cycle counter \*)

Direction: VarGlobal  
Data type: DINT

Attribute: Read

### **Variable \_\_SYSVA\_CYCLEDATE**

(\* Timestamp of the beginning of the cycle in milliseconds (ms) \*)

Direction: VarGlobal

Data type: TIME

Attribute: Read

### **Variable \_\_SYSVA\_KVBPERR**

(\* Kernel variable binding producing error (production error) \*)

Direction: VarGlobal

Data type: BOOL

Attribute: Read

### **Variable \_\_SYSVA\_KVBCERR**

(\* Kernel variable binding consuming error (consumption error) \*)

Direction: VarGlobal

Data type: BOOL

Attribute: Read/Write

### **Variable \_\_SYSVA\_RESNAME**

(\* Resource name (max length=255) \*)

Direction: VarGlobal

Data type: STRING

Attribute: Read

### **Variable \_\_SYSVA\_SCANCNT**

(\* Input scan counter \*)

Direction: VarGlobal

Data type: DINT

Attribute: Read

### **Variable \_\_SYSVA\_TCYCYCTIME**

(\* Programmed cycle time \*)

Direction: VarGlobal

Data type: TIME

Attribute: Read/Write

### **Variable \_\_SYSVA\_TCYCURRENT**

(\* Current cycle time \*)

Direction: VarGlobal

Data type: TIME

Attribute: Read

### **Variable \_\_SYSVA\_TCYMAXIMUM**

(\* Maximum cycle time since last start \*)

Direction: VarGlobal  
Data type: TIME  
Attribute: Read

### **Variable \_\_SYSVA\_TCYOVERFLOW**

(\* Number of cycle overflows \*)

Direction: VarGlobal  
Data type: DINT  
Attribute: Read

### **Variable \_\_SYSVA\_RESMODE**

(\* Resource execution mode \*)

Direction: VarGlobal  
Data type: SINT  
Attribute: Read

### **Variable \_\_SYSVA\_CCEXEC**

(\* Execute one cycle when application is in cycle to cycle mode \*)

Direction: VarGlobal  
Data type: BOOL  
Attribute: Read/Write

### **Variable \_\_SYSVA\_REMOTE**

(\* Remote status \*)

Direction: VarGlobal  
Data type: BOOL  
Attribute: Read

### **Variable \_\_SYSVA\_SUSPEND\_ID**

(\* Last Suspend ID \*)

Direction: VarGlobal  
Data type: UINT  
Attribute: Read

### **Variable \_\_SYSVA\_TCYWDG**

(\* Software Watchdog \*)

Direction: VarGlobal  
Data type: UDINT  
Attribute: Read/Write

### **Variable \_\_SYSVA\_MAJ\_ERR\_HALT**

(\* Major Error Halted status \*)

Direction: VarGlobal



Data type:            BOOL  
Attribute:            Read

**Variable \_\_SYSVA\_ABORT\_CYCLE**

(\* Aborting Cycle \*)

Direction:            VarGlobal  
Data type:            BOOL  
Attribute:            Read

**Variable \_\_SYSVA\_FIRST\_SCAN**

(\* First scan bit \*)

Direction:            VarGlobal  
Data type:            BOOL  
Attribute:            Read

**Variable \_\_SYSVA\_USER\_DATA\_LOST**

(\* User data lost \*)

Direction:            VarGlobal  
Data type:            BOOL  
Attribute:            Read/Write

**Variable \_\_SYSVA\_POWERUP\_BIT**

(\* Power-up bit \*)

Direction:            VarGlobal  
Data type:            BOOL  
Attribute:            Read

**Variable \_\_SYSVA\_PROJ\_INCOMPLETE**

(\* Project Incomplete \*)

Direction:            VarGlobal  
Data type:            UDINT  
Attribute:            Read

## Controller.Micro850.Micro850.MAIN

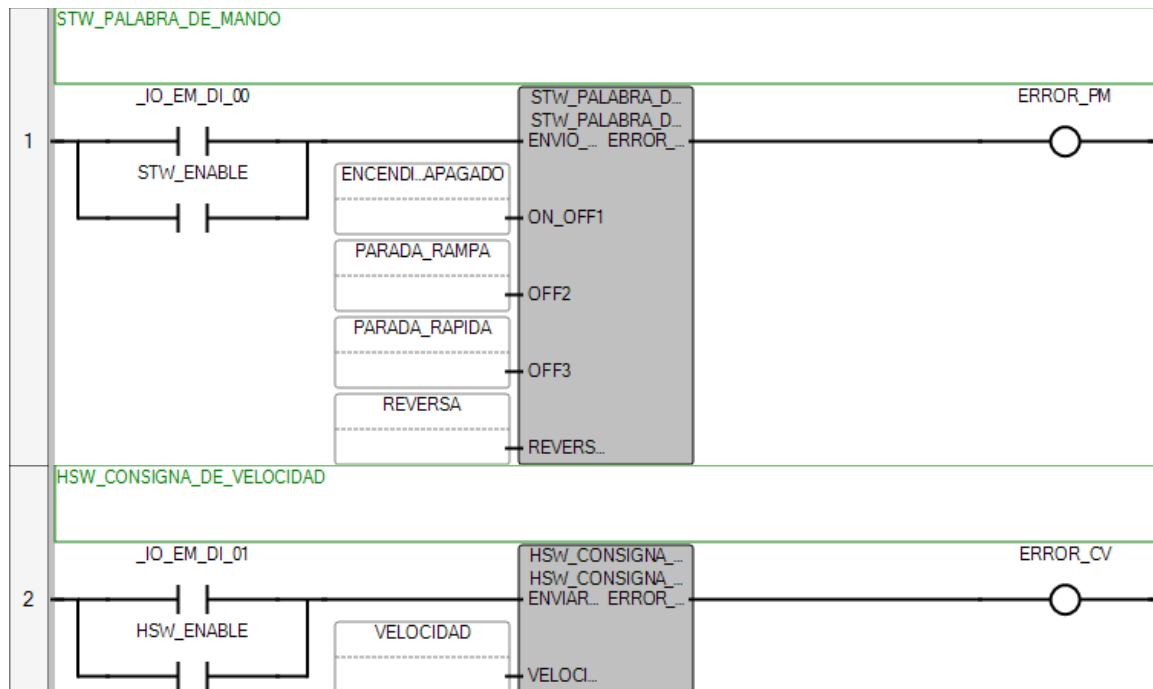

## POU MAIN

The POU defines 11 variable(s).

### Variable STW\_PALABRA\_DE\_MANDO\_1

(\* \*)

Direction: Var  
 Data type: STW\_PALABRA\_DE\_MANDO  
 Attribute: Read/Write

### Variable ENCENDIDO\_APAGADO

(\* \*)

Direction: Var  
 Data type: BOOL  
 Attribute: Read/Write

### Variable PARADA\_RAMPA

(\* \*)

Direction: Var  
 Data type: BOOL  
 Attribute: Read/Write

### Variable PARADA\_RAPIDA

(\* \*)

Direction: Var

Data type:            BOOL  
Attribute:            Read/Write

### **Variable REVERSA**

(\* \*)  
Direction:            Var  
Data type:            BOOL  
Attribute:            Read/Write

### **Variable HSW\_CONSIGNA\_DE\_VELOCIDAD\_1**

(\* \*)  
Direction:            Var  
Data type:            HSW\_CONSIGNA\_DE\_VELOCIDAD  
Attribute:            Read/Write

### **Variable VELOCIDAD**

(\* Ingreso de Velocidad en Herzios \*)  
Direction:            Var  
Data type:            REAL  
Attribute:            Read/Write

### **Variable ERROR\_PM**

(\* \*)  
Direction:            Var  
Data type:            BOOL  
Attribute:            Read/Write

### **Variable ERROR\_CV**

(\* \*)  
Direction:            Var  
Data type:            BOOL  
Attribute:            Read/Write

### **Variable STW\_ENABLE**

(\* \*)  
Direction:            Var  
Data type:            BOOL  
Attribute:            Read/Write

### **Variable HSW\_ENABLE**

(\* \*)  
Direction:            Var  
Data type:            BOOL  
Attribute:            Read/Write

# Controller.Micro850.Micro850.STW\_PALABRA\_DE\_MANDO

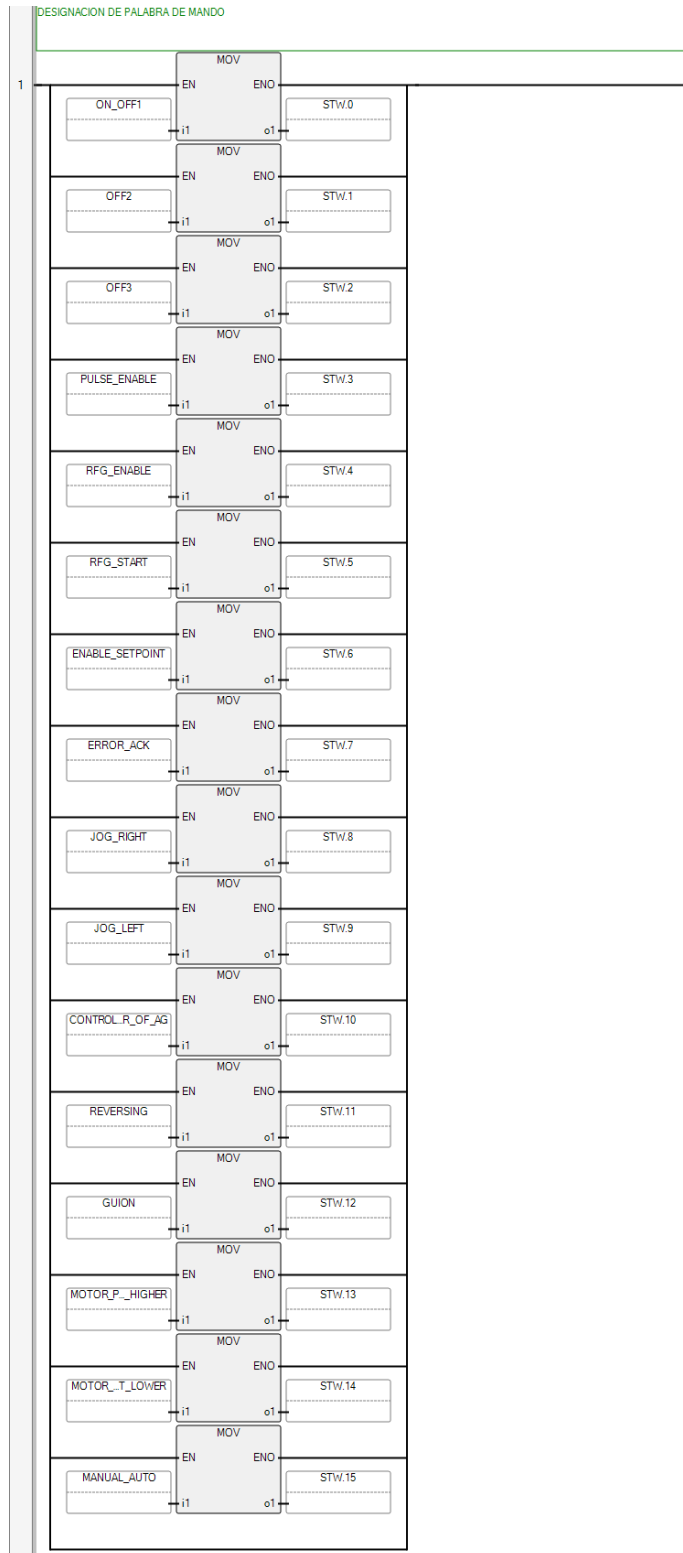

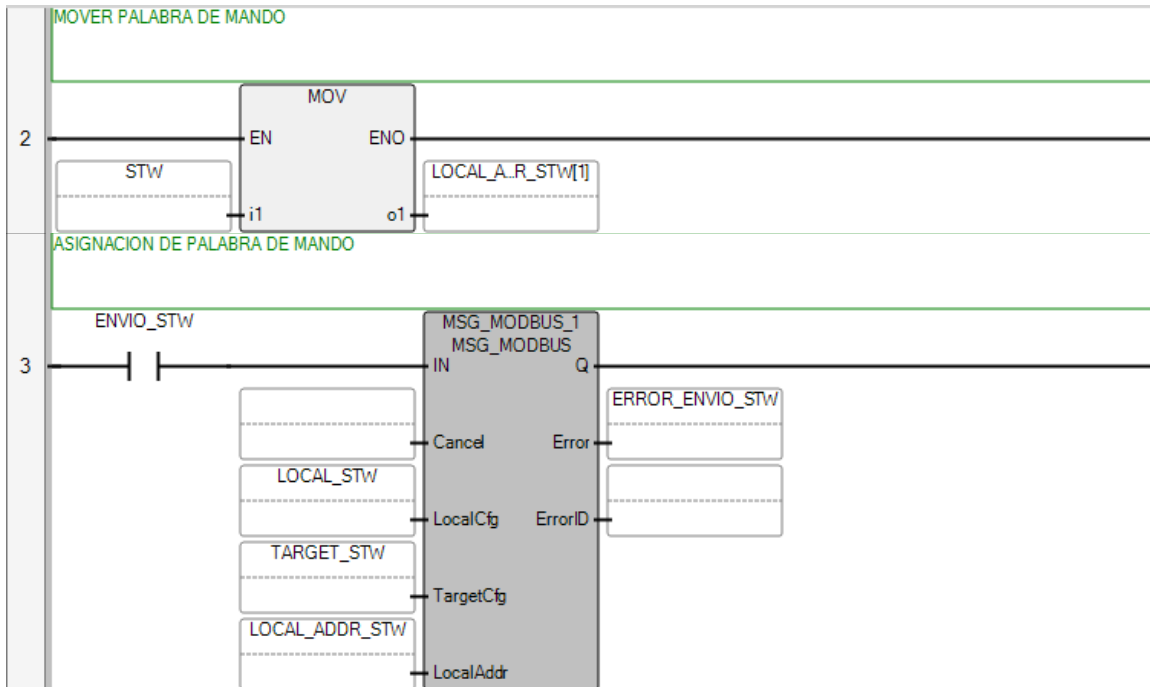

## POU STW\_PALABRA\_DE\_MANDO

The POU defines 23 variable(s).

### Variable ENVI0\_STW

(\* \*)

Direction: VarInput  
 Data type: BOOL  
 Attribute: Read

### Variable ON\_OFF1

(\* ENCENDIDO\_APAGADO \*)

Direction: VarInput  
 Data type: BOOL  
 Attribute: Read

### Variable OFF2

(\* PARADA POR RAMPA \*)

Direction: VarInput  
 Data type: BOOL  
 Attribute: Read

### Variable OFF3

(\* PARADA RAPIDA \*)

Direction: VarInput  
 Data type: BOOL  
 Attribute: Read

### **Variable REVERSING**

(\* REVERSA \*)

Direction: VarInput

Data type: BOOL

Attribute: Read

### **Variable ERROR\_ENVIO\_STW**

(\* \*)

Direction: VarOutput

Data type: BOOL

Attribute: Write

### **Variable CONTROLLER\_OF\_AG**

(\* CONTROLLER OF AG \*)

Direction: Var

Data type: BOOL

Attribute: Read/Write

### **Variable PULSE\_ENABLE**

(\* ENABLE \*)

Direction: Var

Data type: BOOL

Attribute: Read/Write

### **Variable RFG\_ENABLE**

(\* RFG ENABLE \*)

Direction: Var

Data type: BOOL

Attribute: Read/Write

### **Variable RFG\_START**

(\* RFG START \*)

Direction: Var

Data type: BOOL

Attribute: Read/Write

### **Variable ENABLE\_SETPOINT**

(\* ENABLE SETPOINT \*)

Direction: Var

Data type: BOOL

Attribute: Read/Write

### **Variable ERROR\_ACK**

(\* ERROR ACK \*)

Direction: Var  
Data type: BOOL  
Attribute: Read/Write

### **Variable JOG\_RIGHT**

(\* JOG RIGHT \*)

Direction: Var  
Data type: BOOL  
Attribute: Read/Write

### **Variable JOG\_LEFT**

(\* JOG LEFT \*)

Direction: Var  
Data type: BOOL  
Attribute: Read/Write

### **Variable GUION**

(\* NADA \*)

Direction: Var  
Data type: BOOL  
Attribute: Read/Write

### **Variable MOTOR\_POT\_HIGHER**

(\* MOTOR HIGHER \*)

Direction: Var  
Data type: BOOL  
Attribute: Read/Write

### **Variable MOTOR\_POT\_LOWER**

(\* MOTOR LOWER \*)

Direction: Var  
Data type: BOOL  
Attribute: Read/Write

### **Variable MANUAL\_AUTO**

(\* MANUAL-AUTOMATICO \*)

Direction: Var  
Data type: BOOL  
Attribute: Read/Write

### **Variable STW**

(\* \*)

Direction: Var

Data type: WORD  
Attribute: Read/Write

### Variable MSG\_MODBUS\_1

(\* \*)  
Direction: Var  
Data type: MSG\_MODBUS  
Attribute: Read/Write

### Variable LOCAL\_STW

(\* \*)  
Direction: Var  
Data type: MODBUSLOCPARA  
Attribute: Read/Write

### Variable TARGET\_STW

(\* \*)  
Direction: Var  
Data type: MODBUSTARPARA  
Attribute: Read/Write

### Variable LOCAL\_ADDR\_STW

(\* \*)  
Direction: Var  
Data type: MODBUSLOCADDR  
Attribute: Read/Write

## Controller.Micro850.Micro850.ZSW\_PALABRA\_DE\_ESTADO

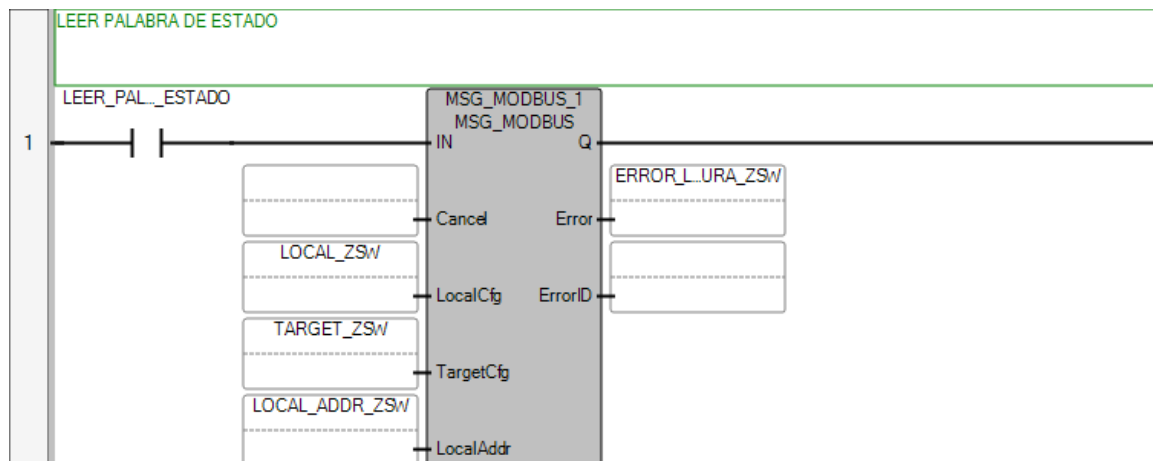



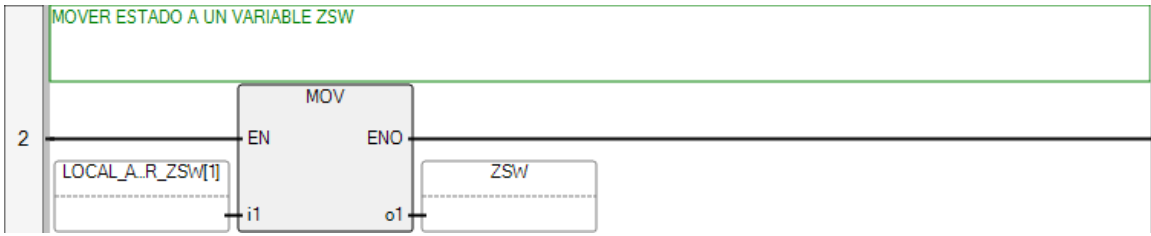

3

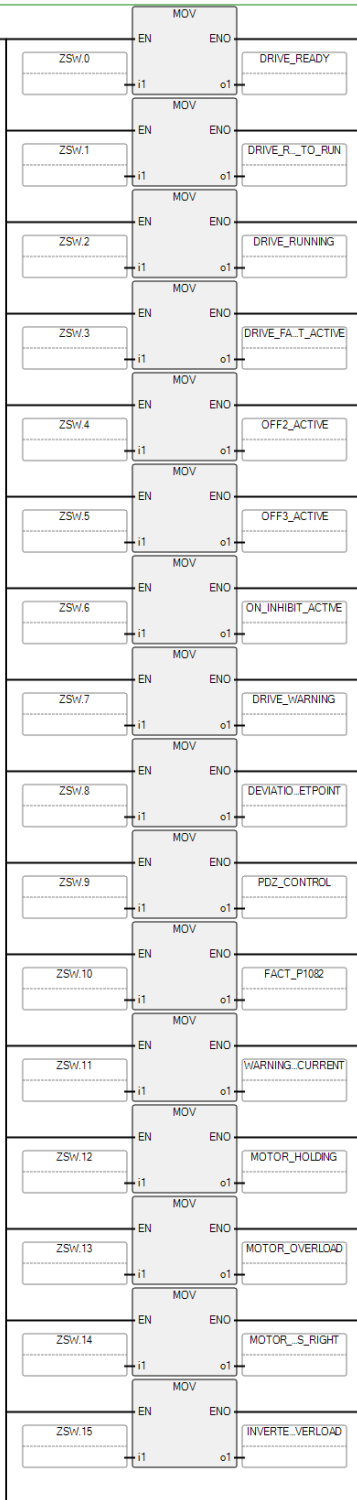

## **POU ZSW\_PALABRA\_DE\_ESTADO**

The POU defines 23 variable(s).

### **Variable LEER\_PALABRA\_ESTADO**

(\* EMPEZAR LA LECTURA \*)

Direction: VarInput  
Data type: BOOL  
Attribute: Read

### **Variable ERROR\_LLECTURA\_ZSW**

(\* \*)

Direction: VarOutput  
Data type: BOOL  
Attribute: Write

### **Variable DRIVE\_READY**

(\* \*)

Direction: VarOutput  
Data type: BOOL  
Attribute: Write

### **Variable DRIVE\_READY\_TO\_RUN**

(\* \*)

Direction: VarOutput  
Data type: BOOL  
Attribute: Write

### **Variable DRIVE\_RUNNING**

(\* \*)

Direction: VarOutput  
Data type: BOOL  
Attribute: Write

### **Variable DRIVE\_FAULT\_ACTIVE**

(\* \*)

Direction: VarOutput  
Data type: BOOL  
Attribute: Write

### **Variable OFF2\_ACTIVE**

(\* \*)

Direction: VarOutput  
Data type: BOOL  
Attribute: Write

### **Variable OFF3\_ACTIVE**

(\* \*)

Direction: VarOutput  
Data type: BOOL  
Attribute: Write

### **Variable ON\_INHIBIT\_ACTIVE**

(\* \*)

Direction: VarOutput  
Data type: BOOL  
Attribute: Write

### **Variable DRIVE\_WARNING**

(\* \*)

Direction: VarOutput  
Data type: BOOL  
Attribute: Write

### **Variable DEVIATION\_SETPOINT**

(\* \*)

Direction: VarOutput  
Data type: BOOL  
Attribute: Write

### **Variable PDZ\_CONTROL**

(\* \*)

Direction: VarOutput  
Data type: BOOL  
Attribute: Write

### **Variable FACT\_P1082**

(\* \*)

Direction: VarOutput  
Data type: BOOL  
Attribute: Write

### **Variable WARNING\_MOTOR\_CURRENT**

(\* \*)

Direction: VarOutput  
Data type: BOOL  
Attribute: Write

### **Variable MOTOR\_HOLDING**

(\* \*)

Direction: VarOutput

Data type: BOOL  
Attribute: Write

### **Variable MOTOR\_OVERLOAD**

(\* \*)  
Direction: VarOutput  
Data type: BOOL  
Attribute: Write

### **Variable MOTOR\_RUNS\_RIGHT**

(\* \*)  
Direction: VarOutput  
Data type: BOOL  
Attribute: Write

### **Variable INVERTER\_OVERLOAD**

(\* \*)  
Direction: VarOutput  
Data type: BOOL  
Attribute: Write

### **Variable MSG\_MODBUS\_1**

(\* \*)  
Direction: Var  
Data type: MSG\_MODBUS  
Attribute: Read/Write

### **Variable LOCAL\_ZSW**

(\* \*)  
Direction: Var  
Data type: MODBUSLOCPARA  
Attribute: Read/Write

### **Variable TARGET\_ZSW**

(\* \*)  
Direction: Var  
Data type: MODBUSTARPARA  
Attribute: Read/Write

### **Variable LOCAL\_ADDR\_ZSW**

(\* \*)  
Direction: Var  
Data type: MODBUSLOCADDR  
Attribute: Read/Write

## Variable ZSW

(\* \*)

Direction: Var  
Data type: WORD  
Attribute: Read/Write

## Controller.Micro850.Micro850.HIW\_VELOCIDAD\_REAL

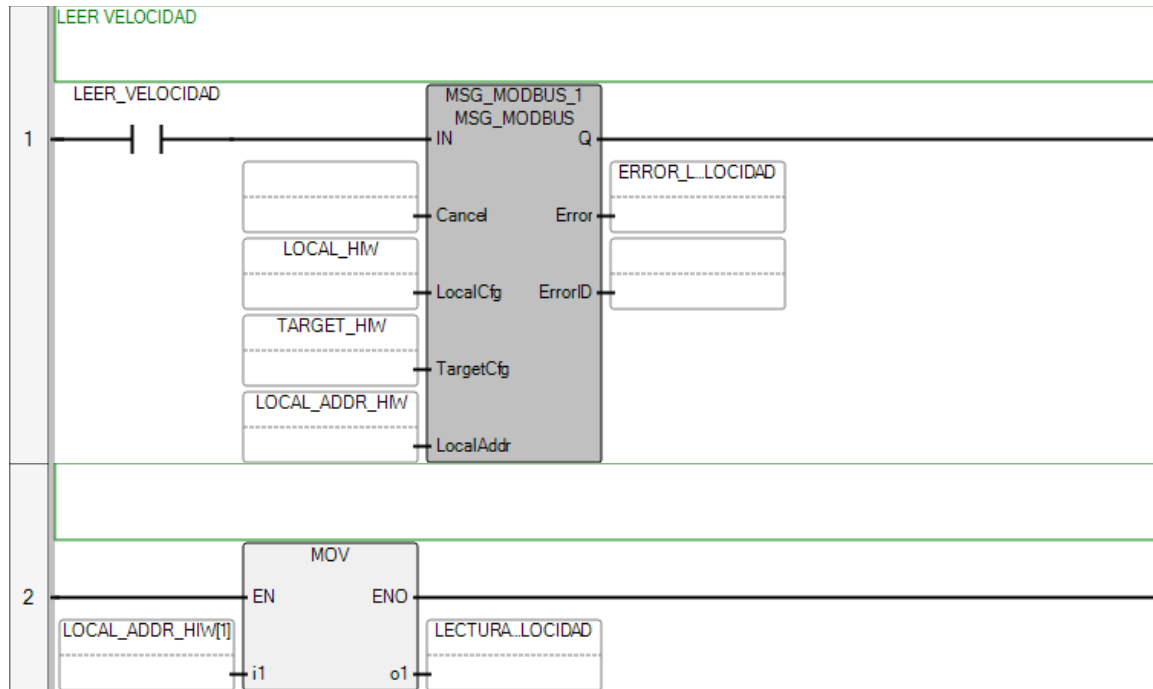

## POU HIW\_VELOCIDAD\_REAL

The POU defines 7 variable(s).

## Variable LEER\_VELOCIDAD

(\* \*)

Direction: VarInput  
Data type: BOOL  
Attribute: Read

## Variable ERROR\_LEER\_VELOCIDAD

(\* \*)

Direction: VarOutput  
Data type: BOOL  
Attribute: Write

## Variable LECTURA\_DE\_VELOCIDAD

(\* \*)

Direction: VarOutput

Data type: WORD  
Attribute: Write

### Variable MSG\_MODBUS\_1

(\* \*)  
Direction: Var  
Data type: MSG\_MODBUS  
Attribute: Read/Write

### Variable LOCAL\_HIW

(\* \*)  
Direction: Var  
Data type: MODBUSLOCPARA  
Attribute: Read/Write

### Variable TARGET\_HIW

(\* \*)  
Direction: Var  
Data type: MODBUSTARPARA  
Attribute: Read/Write

### Variable LOCAL\_ADDR\_HIW

(\* \*)  
Direction: Var  
Data type: MODBUSLOCADDR  
Attribute: Read/Write

## Controller.Micro850.Micro850.HSW\_CONSIGNA\_DE\_VELOCIDAD

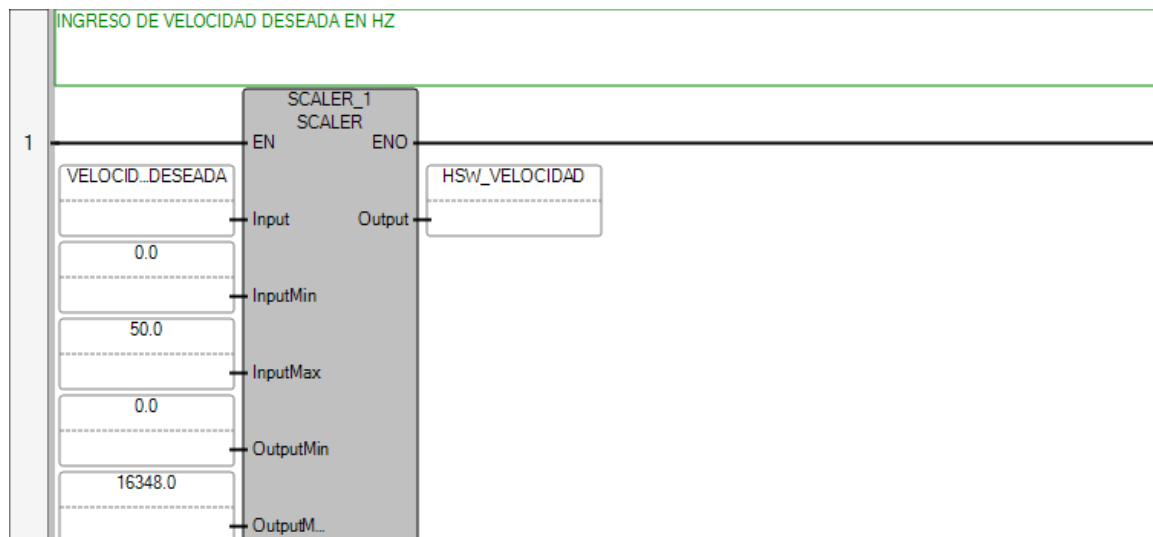

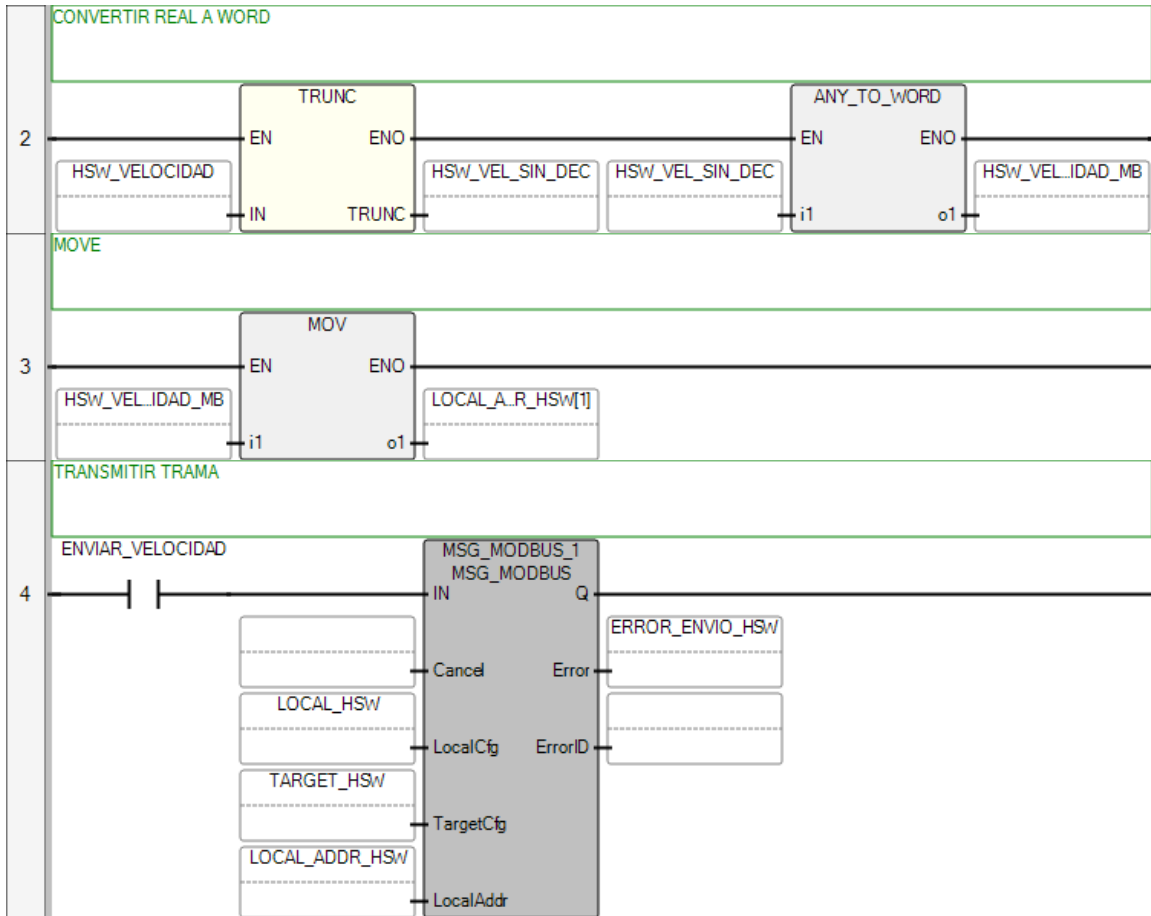

## POU HSW\_CONSIGNA\_DE\_VELOCIDAD

The POU defines 11 variable(s).

### Variable ENVIAR\_VELOCIDAD

(\* \*)

Direction: VarInput  
 Data type: BOOL  
 Attribute: Read

### Variable VELOCIDAD\_DESEADA

(\* \*)

Direction: VarInput  
 Data type: REAL  
 Attribute: Read

### Variable ERROR\_ENVIO\_HSW

(\* \*)

Direction: VarOutput  
 Data type: BOOL  
 Attribute: Write



### **Variable HSW\_VELOCIDAD**

(\* VELOCIDAD EN FRECUENCIA \*)

Direction: Var  
Data type: REAL  
Attribute: Read/Write

### **Variable HSW\_VELOCIDAD\_MB**

(\* \*)

Direction: Var  
Data type: WORD  
Attribute: Read/Write

### **Variable MSG\_MODBUS\_1**

(\* \*)

Direction: Var  
Data type: MSG\_MODBUS  
Attribute: Read/Write

### **Variable LOCAL\_HSW**

(\* \*)

Direction: Var  
Data type: MODBUSLOCPARA  
Attribute: Read/Write

### **Variable TARGET\_HSW**

(\* \*)

Direction: Var  
Data type: MODBUSTARPARA  
Attribute: Read/Write

### **Variable LOCAL\_ADDR\_HSW**

(\* \*)

Direction: Var  
Data type: MODBUSLOCADDR  
Attribute: Read/Write

### **Variable SCALER\_1**

(\* \*)

Direction: Var  
Data type: SCALER  
Attribute: Read/Write

## Variable HSW\_VEL\_SIN\_DEC

(\* \*)

Direction:            Var  
Data type:            REAL  
Attribute:            Read/Write

## **ANEXO B**

### **Programación del Micro 850 – ABB ACS355**

## Configuration Micro850

The detailed description of the configuration goes here

## Resource Micro850

(\* \*)

Status:       Readable, Modifiable, Deletable

The resource defines 45 variable(s).

### Variable \_IO\_EM\_DO\_00

(\* \*)

Direction:       VarDirectlyRepresented

Data type:        BOOL

Attribute:        Read/Write

Direct variable (Channel): %QX0.0.0

### Variable \_IO\_EM\_DO\_01

(\* \*)

Direction:       VarDirectlyRepresented

Data type:        BOOL

Attribute:        Read/Write

Direct variable (Channel): %QX0.0.1

### Variable \_IO\_EM\_DO\_02

(\* \*)

Direction:       VarDirectlyRepresented

Data type:        BOOL

Attribute:        Read/Write

Direct variable (Channel): %QX0.0.2

### Variable \_IO\_EM\_DO\_03

(\* \*)

Direction:       VarDirectlyRepresented

Data type:        BOOL

Attribute:        Read/Write

Direct variable (Channel): %QX0.0.3

### Variable \_IO\_EM\_DO\_04

(\* \*)

Direction:       VarDirectlyRepresented

Data type:        BOOL

Attribute:        Read/Write

Direct variable (Channel): %QX0.0.4

### **Variable \_IO\_EM\_DO\_05**

(\* \*)

Direction: VarDirectlyRepresented  
Data type: BOOL  
Attribute: Read/Write  
Direct variable (Channel): %QX0.0.5

### **Variable \_IO\_EM\_DO\_06**

(\* \*)

Direction: VarDirectlyRepresented  
Data type: BOOL  
Attribute: Read/Write  
Direct variable (Channel): %QX0.0.6

### **Variable \_IO\_EM\_DO\_07**

(\* \*)

Direction: VarDirectlyRepresented  
Data type: BOOL  
Attribute: Read/Write  
Direct variable (Channel): %QX0.0.7

### **Variable \_IO\_EM\_DO\_08**

(\* \*)

Direction: VarDirectlyRepresented  
Data type: BOOL  
Attribute: Read/Write  
Direct variable (Channel): %QX0.0.8

### **Variable \_IO\_EM\_DO\_09**

(\* \*)

Direction: VarDirectlyRepresented  
Data type: BOOL  
Attribute: Read/Write  
Direct variable (Channel): %QX0.0.9

### **Variable \_IO\_EM\_DI\_00**

(\* \*)

Direction: VarDirectlyRepresented  
Data type: BOOL  
Attribute: Read  
Direct variable (Channel): %IX0.1.0

### **Variable \_IO\_EM\_DI\_01**

(\* \*)

Direction: VarDirectlyRepresented  
Data type: BOOL

Attribute: Read  
Direct variable (Channel): %IX0.1.1

### **Variable \_IO\_EM\_DI\_02**

(\* \*)  
Direction: VarDirectlyRepresented  
Data type: BOOL  
Attribute: Read  
Direct variable (Channel): %IX0.1.2

### **Variable \_IO\_EM\_DI\_03**

(\* \*)  
Direction: VarDirectlyRepresented  
Data type: BOOL  
Attribute: Read  
Direct variable (Channel): %IX0.1.3

### **Variable \_IO\_EM\_DI\_04**

(\* \*)  
Direction: VarDirectlyRepresented  
Data type: BOOL  
Attribute: Read  
Direct variable (Channel): %IX0.1.4

### **Variable \_IO\_EM\_DI\_05**

(\* \*)  
Direction: VarDirectlyRepresented  
Data type: BOOL  
Attribute: Read  
Direct variable (Channel): %IX0.1.5

### **Variable \_IO\_EM\_DI\_06**

(\* \*)  
Direction: VarDirectlyRepresented  
Data type: BOOL  
Attribute: Read  
Direct variable (Channel): %IX0.1.6

### **Variable \_IO\_EM\_DI\_07**

(\* \*)  
Direction: VarDirectlyRepresented  
Data type: BOOL  
Attribute: Read  
Direct variable (Channel): %IX0.1.7

### **Variable \_IO\_EM\_DI\_08**

(\* \*)

Direction: VarDirectlyRepresented  
Data type: BOOL  
Attribute: Read  
Direct variable (Channel): %IX0.1.8

### **Variable \_IO\_EM\_DI\_09**

(\* \*)

Direction: VarDirectlyRepresented  
Data type: BOOL  
Attribute: Read  
Direct variable (Channel): %IX0.1.9

### **Variable \_IO\_EM\_DI\_10**

(\* \*)

Direction: VarDirectlyRepresented  
Data type: BOOL  
Attribute: Read  
Direct variable (Channel): %IX0.1.10

### **Variable \_IO\_EM\_DI\_11**

(\* \*)

Direction: VarDirectlyRepresented  
Data type: BOOL  
Attribute: Read  
Direct variable (Channel): %IX0.1.11

### **Variable \_IO\_EM\_DI\_12**

(\* \*)

Direction: VarDirectlyRepresented  
Data type: BOOL  
Attribute: Read  
Direct variable (Channel): %IX0.1.12

### **Variable \_IO\_EM\_DI\_13**

(\* \*)

Direction: VarDirectlyRepresented  
Data type: BOOL  
Attribute: Read  
Direct variable (Channel): %IX0.1.13

### **Variable \_\_SYSVA\_CYCLECNT**

(\* Cycle counter \*)

Direction: VarGlobal  
Data type: DINT

Attribute: Read

### **Variable \_\_SYSVA\_CYCLEDATE**

(\* Timestamp of the beginning of the cycle in milliseconds (ms) \*)

Direction: VarGlobal

Data type: TIME

Attribute: Read

### **Variable \_\_SYSVA\_KVBPERR**

(\* Kernel variable binding producing error (production error) \*)

Direction: VarGlobal

Data type: BOOL

Attribute: Read

### **Variable \_\_SYSVA\_KVBCERR**

(\* Kernel variable binding consuming error (consumption error) \*)

Direction: VarGlobal

Data type: BOOL

Attribute: Read/Write

### **Variable \_\_SYSVA\_RESNAME**

(\* Resource name (max length=255) \*)

Direction: VarGlobal

Data type: STRING

Attribute: Read

### **Variable \_\_SYSVA\_SCANCNT**

(\* Input scan counter \*)

Direction: VarGlobal

Data type: DINT

Attribute: Read

### **Variable \_\_SYSVA\_TCYCYCTIME**

(\* Programmed cycle time \*)

Direction: VarGlobal

Data type: TIME

Attribute: Read/Write

### **Variable \_\_SYSVA\_TCYCURRENT**

(\* Current cycle time \*)

Direction: VarGlobal

Data type: TIME

Attribute: Read



**Variable \_\_SYSVA\_TCYMAXIMUM**

(\* Maximum cycle time since last start \*)

Direction: VarGlobal  
Data type: TIME  
Attribute: Read

**Variable \_\_SYSVA\_TCYOVERFLOW**

(\* Number of cycle overflows \*)

Direction: VarGlobal  
Data type: DINT  
Attribute: Read

**Variable \_\_SYSVA\_RESMODE**

(\* Resource execution mode \*)

Direction: VarGlobal  
Data type: SINT  
Attribute: Read

**Variable \_\_SYSVA\_CCEXEC**

(\* Execute one cycle when application is in cycle to cycle mode \*)

Direction: VarGlobal  
Data type: BOOL  
Attribute: Read/Write

**Variable \_\_SYSVA\_REMOTE**

(\* Remote status \*)

Direction: VarGlobal  
Data type: BOOL  
Attribute: Read

**Variable \_\_SYSVA\_SUSPEND\_ID**

(\* Last Suspend ID \*)

Direction: VarGlobal  
Data type: UINT  
Attribute: Read

**Variable \_\_SYSVA\_TCYWDG**

(\* Software Watchdog \*)

Direction: VarGlobal  
Data type: UDINT  
Attribute: Read/Write

**Variable \_\_SYSVA\_MAJ\_ERR\_HALT**

(\* Major Error Halted status \*)

Direction: VarGlobal

Data type: BOOL  
Attribute: Read

### Variable **\_\_SYSVA\_ABORT\_CYCLE**

(\* Aborting Cycle \*)

Direction: VarGlobal  
Data type: BOOL  
Attribute: Read

### Variable **\_\_SYSVA\_FIRST\_SCAN**

(\* First scan bit \*)

Direction: VarGlobal  
Data type: BOOL  
Attribute: Read

### Variable **\_\_SYSVA\_USER\_DATA\_LOST**

(\* User data lost \*)

Direction: VarGlobal  
Data type: BOOL  
Attribute: Read/Write

### Variable **\_\_SYSVA\_POWERUP\_BIT**

(\* Power-up bit \*)

Direction: VarGlobal  
Data type: BOOL  
Attribute: Read

### Variable **\_\_SYSVA\_PROJ\_INCOMPLETE**

(\* Project Incomplete \*)

Direction: VarGlobal  
Data type: UDINT  
Attribute: Read

## Controller.Micro850.Micro850.MAIN

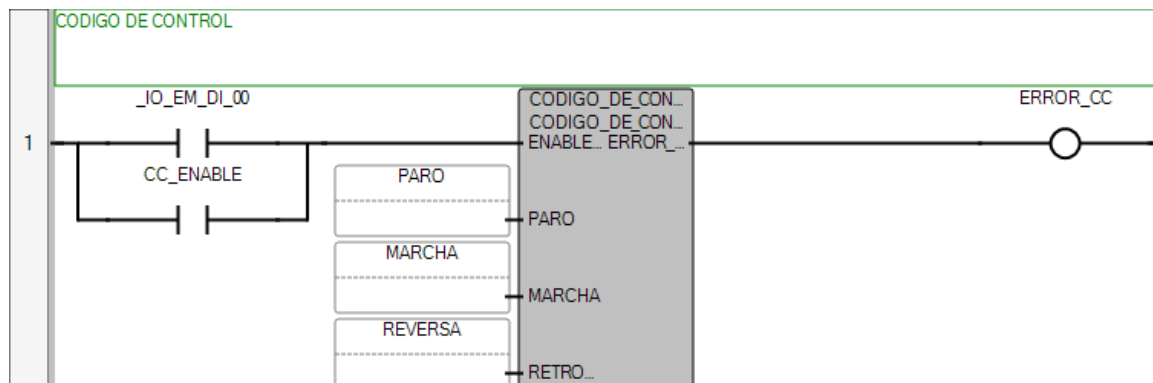

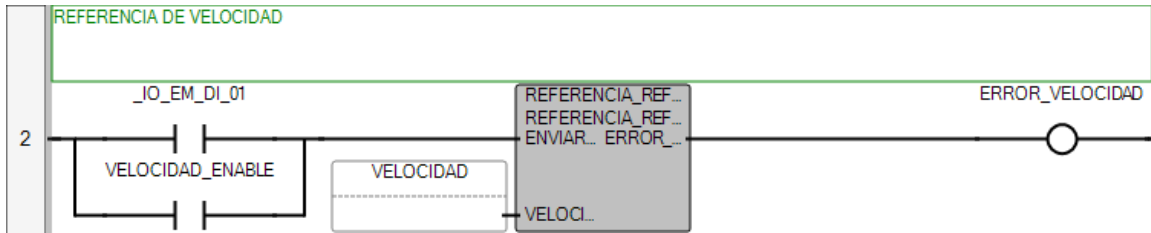

## POU MAIN

The POU defines 10 variable(s).

### Variable CODIGO\_DE\_CONTROLO\_301\_ADD\_31\_1

(\* \*)

Direction: Var

Data type: CODIGO\_DE\_CONTROLO\_301\_ADD\_31

Attribute: Read/Write

### Variable PARO

(\* \*)

Direction: Var

Data type: BOOL

Attribute: Read/Write

### Variable MARCHA

(\* \*)

Direction: Var

Data type: BOOL

Attribute: Read/Write

### Variable REVERSA

(\* \*)

Direction: Var

Data type: BOOL

Attribute: Read/Write

### Variable CC\_ENABLE

(\* \*)

Direction: Var

Data type: BOOL

Attribute: Read/Write

### Variable ERROR\_CC

(\* \*)

Direction: Var

Data type: BOOL

Attribute: Read/Write

### **Variable VELOCIDAD\_ENABLE**

(\* \*)

Direction: Var  
Data type: BOOL  
Attribute: Read/Write

### **Variable REFERENCIA\_REF\_ADD\_02\_1**

(\* \*)

Direction: Var  
Data type: REFERENCIA\_REF\_ADD\_02  
Attribute: Read/Write

### **Variable VELOCIDAD**

(\* \*)

Direction: Var  
Data type: REAL  
Attribute: Read/Write

### **Variable ERROR\_VELOCIDAD**

(\* \*)

Direction: Var  
Data type: BOOL  
Attribute: Read/Write

# Controller.Micro850.Micro850.CODIGO\_DE\_CONTROL0\_301\_ADD\_31

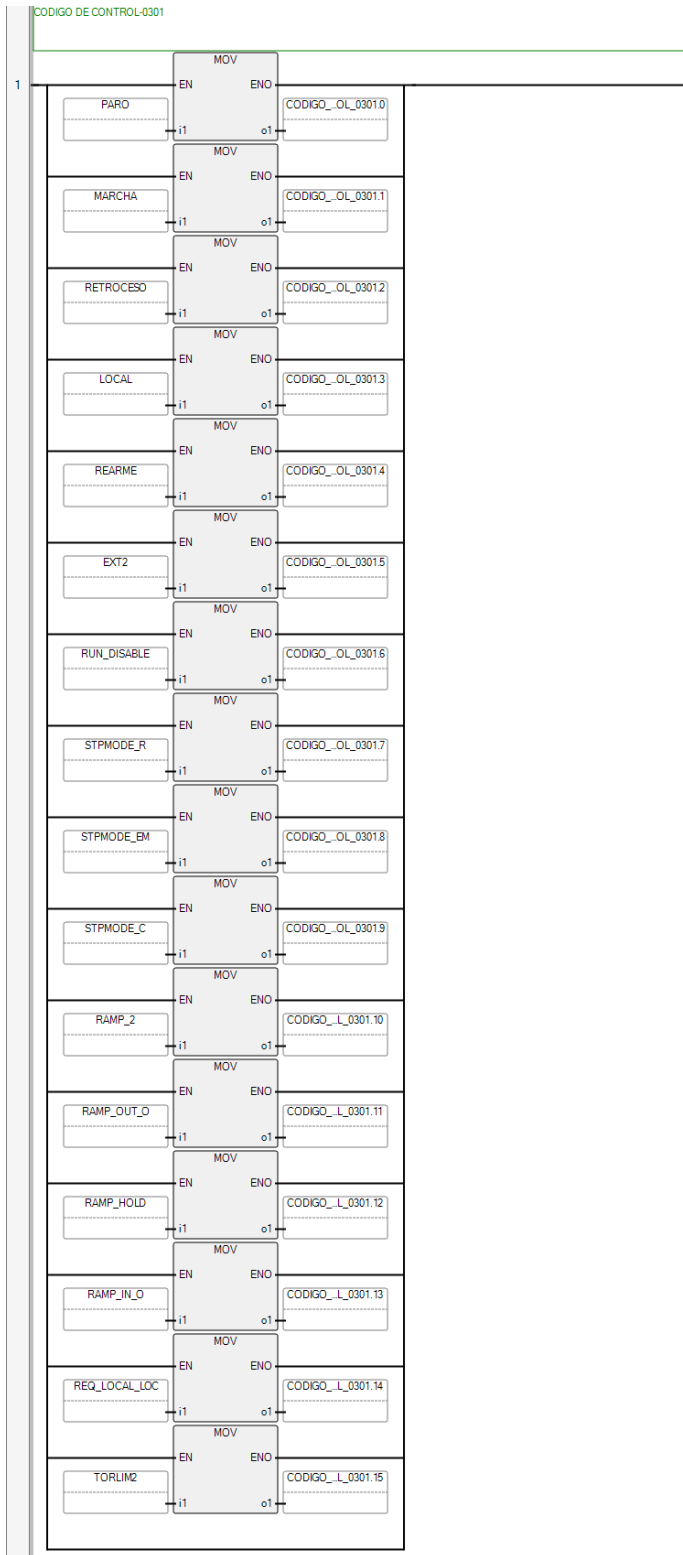

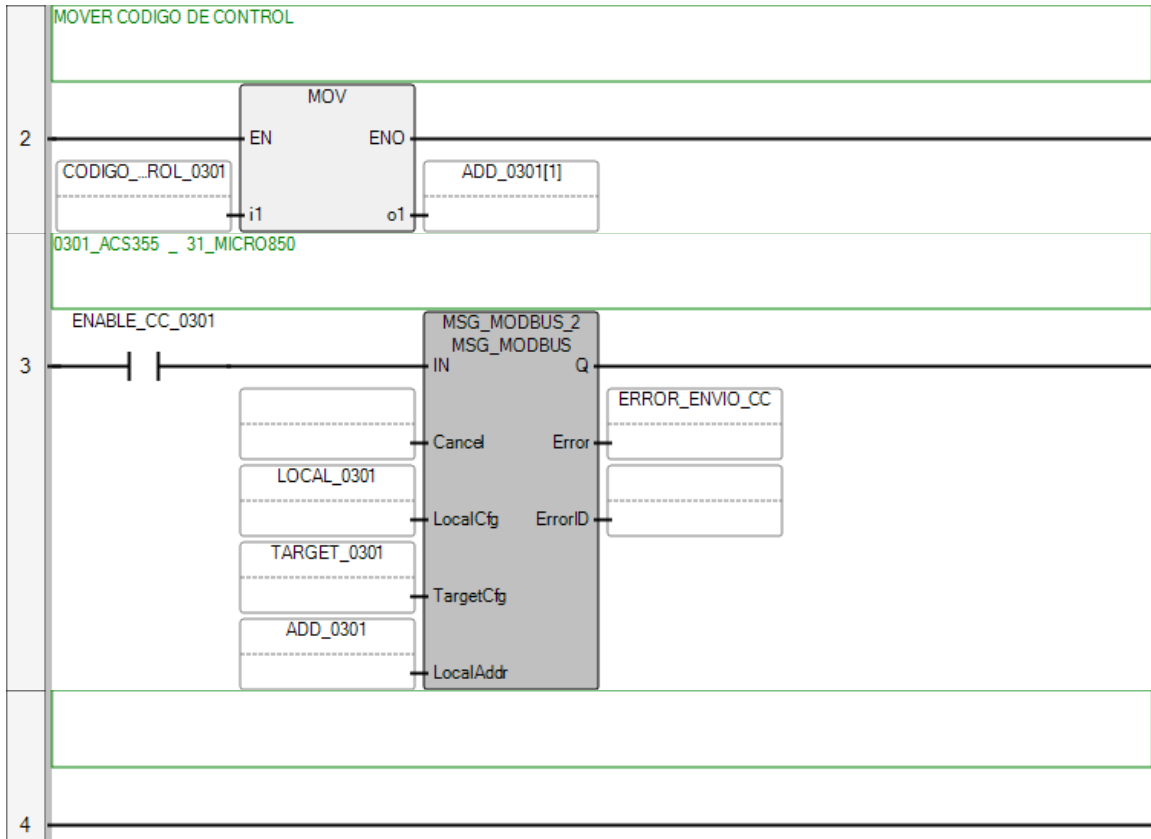

## POU CODIGO\_DE\_CONTROL0\_301\_ADD\_31

The POU defines 23 variable(s).

### Variable ENABLE\_CC\_0301

(\* \*)

Direction: VarInput  
 Data type: BOOL  
 Attribute: Read

### Variable PARO

(\* \*)

Direction: VarInput  
 Data type: BOOL  
 Attribute: Read

### Variable MARCHA

(\* \*)

Direction: VarInput  
 Data type: BOOL  
 Attribute: Read

### **Variable RETROCESO**

(\* \*)

Direction: VarInput  
Data type: BOOL  
Attribute: Read

### **Variable ERROR\_ENVIO\_CC**

(\* \*)

Direction: VarOutput  
Data type: BOOL  
Attribute: Write

### **Variable LOCAL**

(\* \*)

Direction: Var  
Data type: BOOL  
Attribute: Read/Write

### **Variable REARME**

(\* \*)

Direction: Var  
Data type: BOOL  
Attribute: Read/Write

### **Variable EXT2**

(\* \*)

Direction: Var  
Data type: BOOL  
Attribute: Read/Write

### **Variable RUN\_DISABLE**

(\* \*)

Direction: Var  
Data type: BOOL  
Attribute: Read/Write

### **Variable STPMODE\_R**

(\* \*)

Direction: Var  
Data type: BOOL  
Attribute: Read/Write

### **Variable STPMODE\_EM**

(\* \*)

Direction: Var

Data type:            BOOL  
Attribute:            Read/Write

### **Variable STPMODE\_C**

(\* \*)  
Direction:            Var  
Data type:            BOOL  
Attribute:            Read/Write

### **Variable RAMP\_2**

(\* \*)  
Direction:            Var  
Data type:            BOOL  
Attribute:            Read/Write

### **Variable RAMP\_OUT\_O**

(\* \*)  
Direction:            Var  
Data type:            BOOL  
Attribute:            Read/Write

### **Variable RAMP\_HOLD**

(\* \*)  
Direction:            Var  
Data type:            BOOL  
Attribute:            Read/Write

### **Variable RAMP\_IN\_O**

(\* \*)  
Direction:            Var  
Data type:            BOOL  
Attribute:            Read/Write

### **Variable REQ\_LOCAL\_LOC**

(\* \*)  
Direction:            Var  
Data type:            BOOL  
Attribute:            Read/Write

### **Variable TORLIM2**

(\* \*)  
Direction:            Var  
Data type:            BOOL  
Attribute:            Read/Write



## Variable CODIGO\_CONROL\_0301

(\* \*)

Direction: Var  
Data type: WORD  
Attribute: Read/Write

## Variable MSG\_MODBUS\_2

(\* \*)

Direction: Var  
Data type: MSG\_MODBUS  
Attribute: Read/Write

## Variable ADD\_0301

(\* \*)

Direction: Var  
Data type: MODBUSLOCADDR  
Attribute: Read/Write

## Variable LOCAL\_0301

(\* \*)

Direction: Var  
Data type: MODBUSLOCPARA  
Attribute: Read/Write

## Variable TARGET\_0301

(\* \*)

Direction: Var  
Data type: MODBUSTARPARA  
Attribute: Read/Write

## Controller.Micro850.Micro850.REFERENCIA\_REF\_ADD\_02

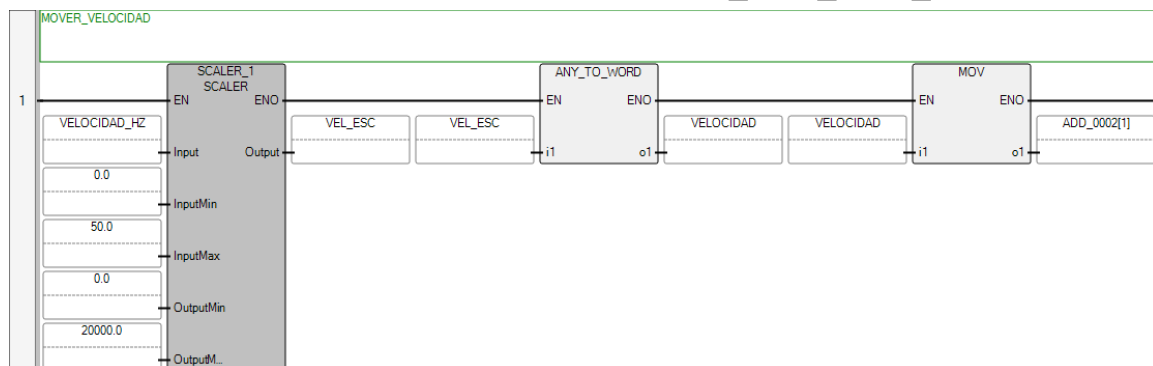

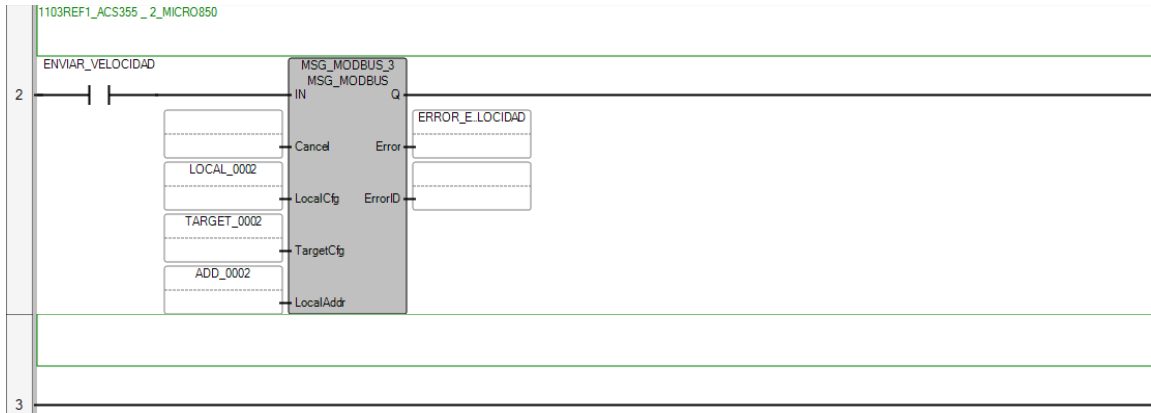

## POU REFERENCIA\_REF\_ADD\_02

The POU defines 10 variable(s).

### Variable ENVIAR\_VELOCIDAD

(\* \*)

Direction: VarInput  
 Data type: BOOL  
 Attribute: Read

### Variable VELOCIDAD\_HZ

(\* \*)

Direction: VarInput  
 Data type: REAL  
 Attribute: Read

### Variable ERROR\_ENVIO\_VELOCIDAD

(\* \*)

Direction: VarOutput  
 Data type: BOOL  
 Attribute: Write

### Variable SCALER\_1

(\* \*)

Direction: Var  
 Data type: SCALER  
 Attribute: Read/Write

### Variable VEL\_ESC

(\* \*)

Direction: Var  
 Data type: REAL  
 Attribute: Read/Write

### **Variable VELOCIDAD**

(\* \*)

Direction: Var  
Data type: WORD  
Attribute: Read/Write

### **Variable MSG\_MODBUS\_3**

(\* \*)

Direction: Var  
Data type: MSG\_MODBUS  
Attribute: Read/Write

### **Variable LOCAL\_0002**

(\* \*)

Direction: Var  
Data type: MODBUSLOCPARA  
Attribute: Read/Write

### **Variable TARGET\_0002**

(\* \*)

Direction: Var  
Data type: MODBUSTARPARA  
Attribute: Read/Write

### **Variable ADD\_0002**

(\* \*)

Direction: Var  
Data type: MODBUSLOCADDR  
Attribute: Read/Write

## **ANEXO C**

### **Programación del S7-1200 – Sinamics V20**

# Bloques de programa

## Main [OB1]

### Main Propiedades

#### General

Nombre	Main	Número	1
Tipo	OB	Idioma	KOP
Numeración	automática		

#### Información

Título	"Main Program Sweep (Cycle)"	Autor	
Comentario		Familia	
Versión	0.1	ID personalizada	

Nombre	Tipo de datos	Valor predet.	Comentario
▼ Input			
Initial_Call	Bool		Initial call of this OB
Remanence	Bool		=True, if remanent data are available
Temp			
Constant			

### Segmento 1: STW\_PALABRA\_DE\_MANDO

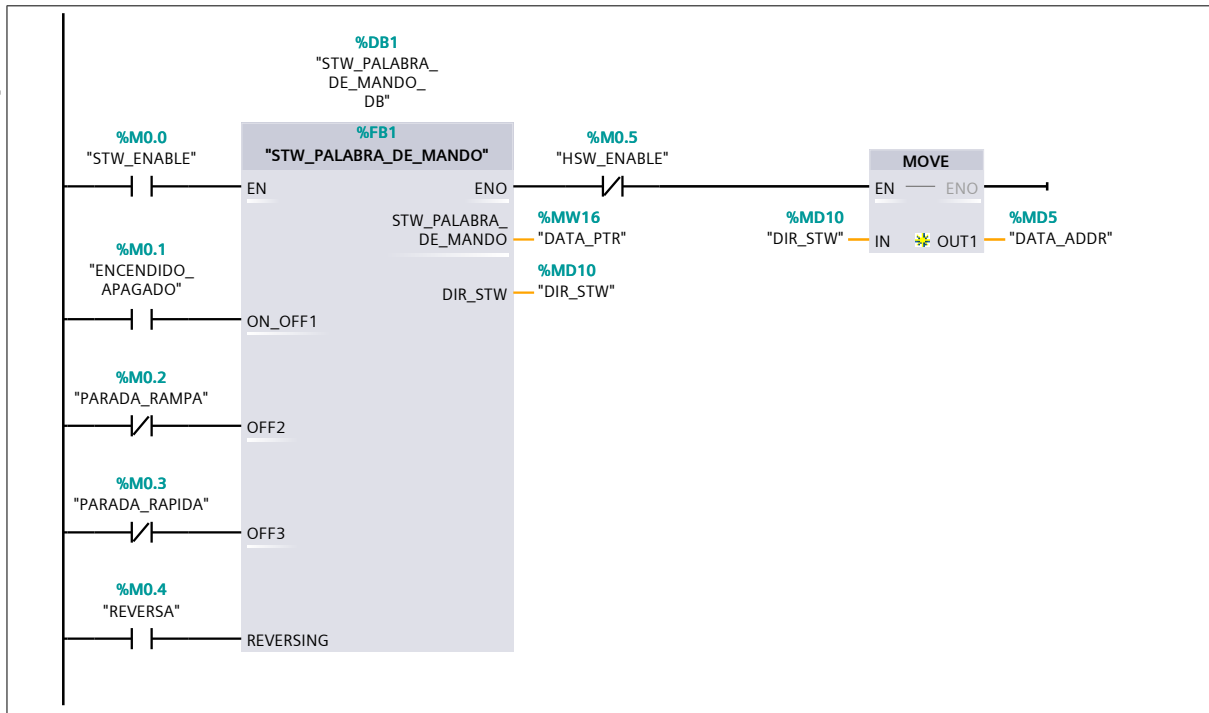

Símbolo	Dirección	Tipo	Comentario
"DATA_ADDR"	%MD5	UDInt	

Owner	Project name	MODBUS_S7-1200_SINAMICS_V20_V13_SP1	Date	12/09/2017	
	Operator	Project path C:\Users\integradora\Desktop\TESIS MODBUS\Documentos\S7 1200 - V20 MODBUS RS232\MODBUS_S7-1200_SINAMICS_V20_V13_SP1			
Designed By	Location				
Checked By	Description 1st	Language			es-ES
Approved By	Description 2nd	1st View	Version	Sheet 1 - 1	

Símbolo	Dirección	Tipo	Comentario
"DATA_PTR"	%MW16	Word	
"DIR_STW"	%MD10	UDInt	
"ENCENDIDO_APAGADO"	%M0.1	Bool	
"HSW_ENABLE"	%M0.5	Bool	
"PARADA_RAMPA"	%M0.2	Bool	
"PARADA_RAPIDA"	%M0.3	Bool	
"REVERSA"	%M0.4	Bool	
"STW_ENABLE"	%M0.0	Bool	

**Segmento 2: HSW\_CONSIGNA\_DE\_VELOCIDAD**

**Segmento 2: HSW\_CONSIGNA\_DE\_VELOCIDAD**

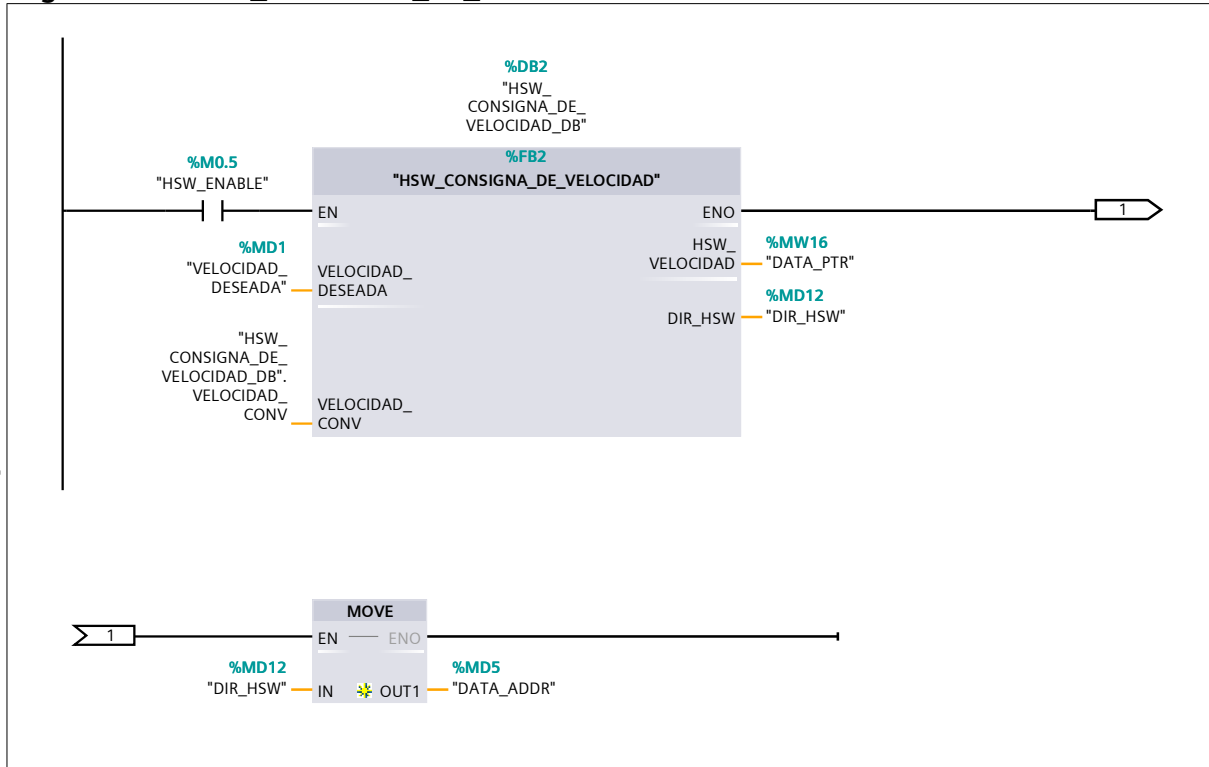

Símbolo	Dirección	Tipo	Comentario
"DATA_ADDR"	%MD5	UDInt	
"DATA_PTR"	%MW16	Word	
"DIR_HSW"	%MD12	UDInt	
"HSW_CONSIGNA_DE_VELOCIDAD_DB".VELOCIDAD_CONV		Real	
"HSW_ENABLE"	%M0.5	Bool	
"VELOCIDAD_DESEADA"	%MD1	Real	

Owner	Project name	MODBUS_S7-1200_SINAMICS_V20_V13_SP1	Date	12/09/2017
	Operator	Project path C:\Users\integradora\Desktop\TESIS MODBUS\Documentos\S7 1200 - V20 MODBUS RS232\MODBUS_S7-1200_SINAMICS_V20_V13_SP1		
Designed By	Location			
Checked By	Description 1st		Language	
Approved By	Description 2nd		es-ES	
	1st View		Version	Sheet 1 - 2

### Segmento 3: INICIO\_COMUNICACION\_MODBUS

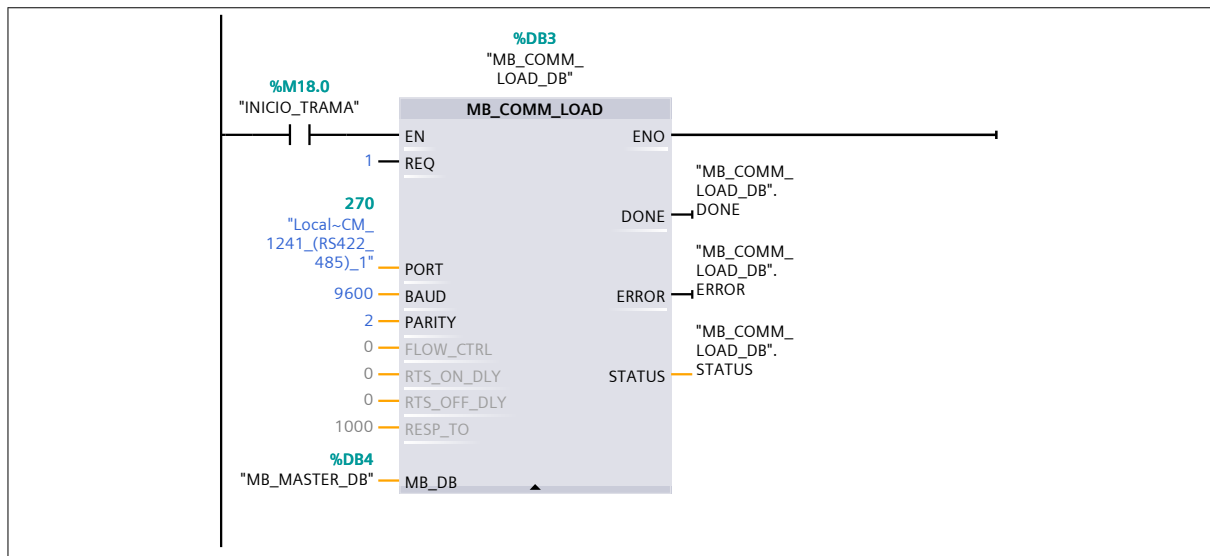

Símbolo	Dirección	Tipo	Comentario
"INICIO_TRAMA"	%M18.0	Bool	
"Local~CM_1241_(RS422_485)_1"	270	PORT	
"MB_COMM_LOAD_D B".DONE		Bool	Boolean indicating completion without error
"MB_COMM_LOAD_D B".ERROR		Bool	Boolean indicating completion with error
"MB_COMM_LOAD_D B".STATUS		Word	Status of the current operation

### Segmento 4:

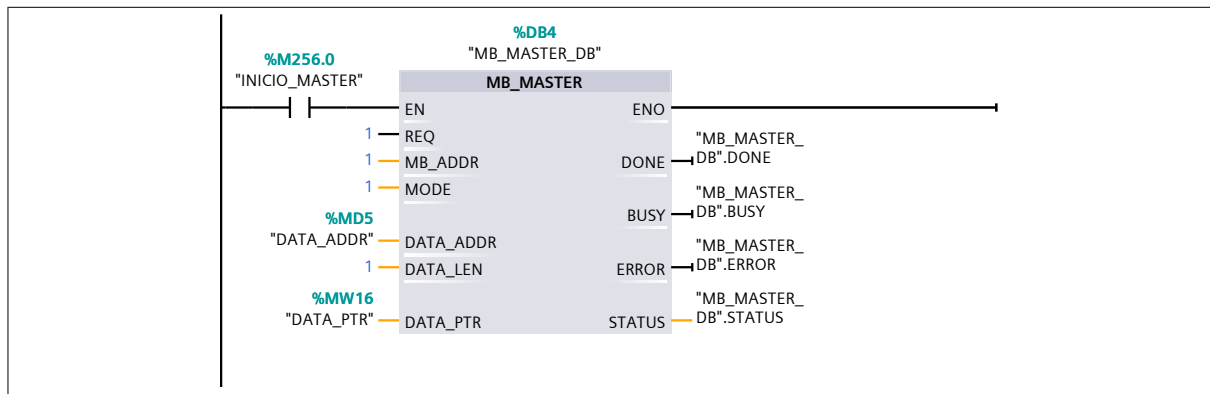

Símbolo	Dirección	Tipo	Comentario
"DATA_ADDR"	%MD5	UDInt	
"DATA_PTR"	%MW16	Word	

Owner	Project name	MODBUS_S7-1200_SINAMICS_V20_V13_SP1	Date	12/09/2017
Operator	Project path	C:\Users\integradora\Desktop\TESIS MODBUS\Documentos\S7 1200 - V20 MODBUS RS232\MODBUS_S7-1200_SINAMICS_V20_V13_SP1		
Designed By	Description 1st			
Checked By	Description 2nd	Language	es-ES	
Approved By	1st View	Version	Sheet 1 - 3	

1

2

3

4

A

Símbolo	Dirección	Tipo	Comentario
"INICIO_MASTER"	%M256.0	Bool	
"MB_MASTER_DB".BUSY		Bool	Boolean indicating operation in progress
"MB_MASTER_DB".DONE		Bool	Boolean indicating completion without error
"MB_MASTER_DB".ERROR		Bool	Boolean indicating completion with error
"MB_MASTER_DB".STATUS		Word	Status or error code of the completed operation

B

C

D

E

F

Owner	Project name	MODBUS_S7-1200_SINAMICS_V20_V13_SP1	Date	12/09/2017
Operator	Project path	C:\Users\integradora\Desktop\TESIS MODBUS\Documentos\S7 1200 - V20 MODBUS RS232\MODBUS_S7-1200_SINAMICS_V20_V13_SP1		
	Location			
Designed By	Description 1st			
Checked By	Description 2nd	Language	es-ES	
Approved By	1st View	Version	Sheet 1 - 4	



# Bloques de programa

## STW\_PALABRA\_DE\_MANDO [FB1]

### STW\_PALABRA\_DE\_MANDO Propiedades

#### General

Nombre	STW_PALABRA_DE_MANDO	Número	1
Tipo	FB	Idioma	KOP
Numeración	automática		

#### Información

Título	STW_PALABRA DE MANDO	Autor	
Comentario		Familia	
Versión	0.1	ID personalizada	

Nombre	Tipo de datos	Valor predet.	Remanencia	Accesible desde HMI	Visible en HMI	Valor de ajuste	Comentario
▼ Input							
ON_OFF1	Bool	false	No remanente	True	True	False	
OFF2	Bool	TRUE	No remanente	True	True	False	
OFF3	Bool	TRUE	No remanente	True	True	False	
REVERSING	Bool	false	No remanente	True	True	False	
▼ Output							
STW_PALABRA_DE_MANDO	Word	16#0	No remanente	True	True	False	
DIR_STW	UDInt	0	No remanente	True	True	False	
InOut							
▼ Static							
PULSE_ENABLE	Bool	TRUE	No remanente	True	True	False	
RFG_ENABLE	Bool	TRUE	No remanente	True	True	False	
RFG_START	Bool	TRUE	No remanente	True	True	False	
ENABLE_SET-POINT	Bool	TRUE	No remanente	True	True	False	
ERROR_ACK	Bool	false	No remanente	True	True	False	
JOG_RIGHT	Bool	false	No remanente	True	True	False	
JOG_LEFT	Bool	false	No remanente	True	True	False	
CONTROL_OF_AG	Bool	TRUE	No remanente	True	True	False	
GUION	Bool	false	No remanente	True	True	False	
MOTOR_P_HIGHER	Bool	false	No remanente	True	True	False	
MOTOR_P_LOWER	Bool	false	No remanente	True	True	False	
MANUAL_AUTO	Bool	false	No remanente	True	True	False	
STW	Word	16#0	No remanente	True	True	False	
Temp							
Constant							

Owner	Project name	MODBUS_S7-1200_SINAMICS_V20_V13_SP1	Date	12/09/2017
Operator	Project path	C:\Users\integradora\Desktop\TESIS MODBUS\Documentos\S7 1200 - V20 MODBUS RS232\MODBUS_S7-1200_SINAMICS_V20_V13_SP1		
Designed By	Description 1st			
Checked By	Description 2nd	Language	es-ES	
Approved By	1st View	Version	Sheet 2 - 1	

**Segmento 1: DESIGNACION DE PALABRA DE MANDO**

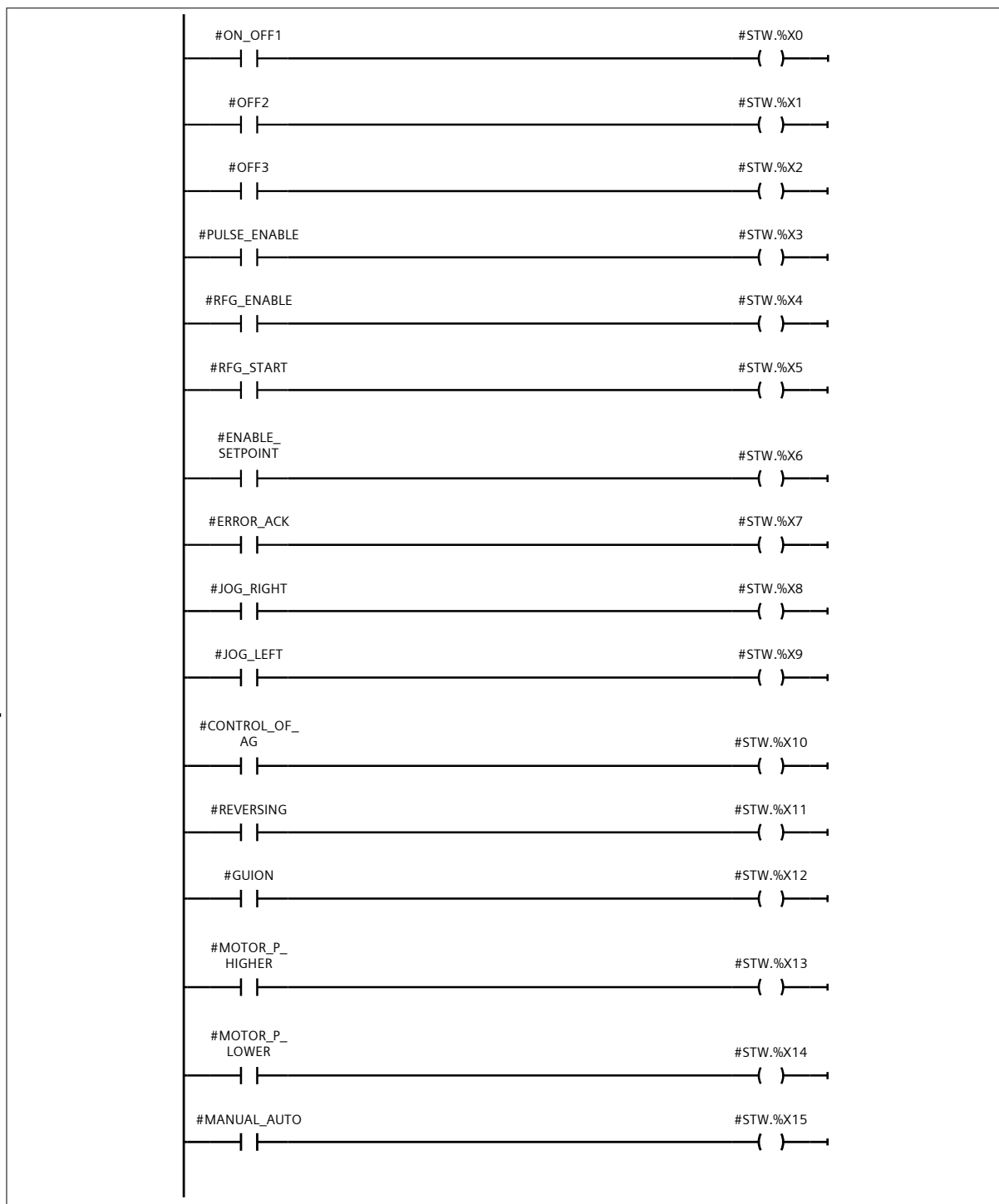

Símbolo	Dirección	Tipo	Comentario
#CONTROL_OF_AG		Bool	
#ENABLE_SETPOINT		Bool	

Owner	Project name	MODBUS_S7-1200_SINAMICS_V20_V13_SP1	Date	12/09/2017
	Operator	Project path C:\Users\integradora\Desktop\TESIS MODBUS\Documentos\S7 1200 - V20 MODBUS RS232\MODBUS_S7-1200_SINAMICS_V20_V13_SP1		
Designed By	Location			
Checked By	Description 1st	Language		
Approved By	Description 2nd	es-ES		Version
	1st View			Sheet 2 - 2

Símbolo	Dirección	Tipo	Comentario
#ERROR_ACK		Bool	
#GUION		Bool	
#JOG_LEFT		Bool	
#JOG_RIGHT		Bool	
#MANUAL_AUTO		Bool	
#MOTOR_P_HIGHER		Bool	
#MOTOR_P_LOWER		Bool	
#OFF2		Bool	
#OFF3		Bool	
#ON_OFF1		Bool	
#PULSE_ENABLE		Bool	
#REVERSING		Bool	
#RFG_ENABLE		Bool	
#RFG_START		Bool	
#STW.%X0		Bool	
#STW.%X1		Bool	
#STW.%X2		Bool	
#STW.%X3		Bool	
#STW.%X4		Bool	
#STW.%X5		Bool	
#STW.%X6		Bool	
#STW.%X7		Bool	
#STW.%X8		Bool	
#STW.%X9		Bool	
#STW.%X10		Bool	
#STW.%X11		Bool	
#STW.%X12		Bool	
#STW.%X13		Bool	
#STW.%X14		Bool	
#STW.%X15		Bool	

### Segmento 2: ENVIO DE PALABRA DE MANDO

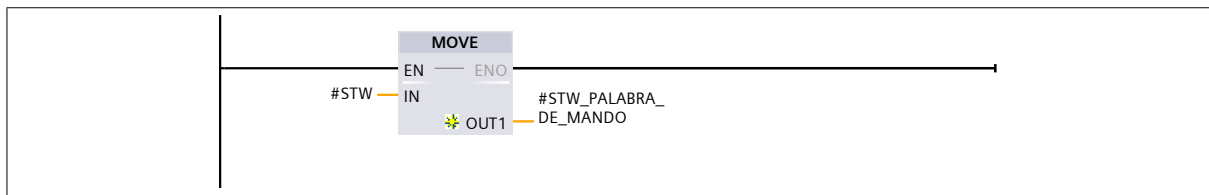

Símbolo	Dirección	Tipo	Comentario
#STW		Word	
#STW_PALABRA_DE_MANDO		Word	

### Segmento 3: DIRECCIONAMIENTO

Owner	Project name	MODBUS_S7-1200_SINAMICS_V20_V13_SP1	Date	12/09/2017
	Operator	Project path C:\Users\integradora\Desktop\TESIS MODBUS\Documentos\S7 1200 - V20 MODBUS RS232\MODBUS_S7-1200_SINAMICS_V20_V13_SP1		
Designed By	Location			
Checked By	Description 1st	Language		
Approved By	Description 2nd	es-ES		Sheet
	1st View	Version	2 - 3	

1

2

3

4

A

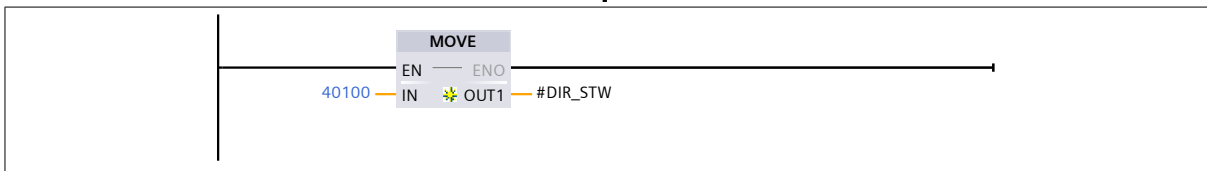

Símbolo	Dirección	Tipo	Comentario
#DIR_STW		UDInt	

B

C

D

E

F

Owner	Project name	MODBUS_S7-1200_SINAMICS_V20_V13_SP1	Date	12/09/2017
	Operator	Project path	C:\Users\integradora\Desktop\TESIS MODBUS\Documentos\S7 1200 - V20 MODBUS RS232\MODBUS_S7-1200_SINAMICS_V20_V13_SP1	
Designed By		Location		
	Description 1st			
Checked By	Description 2nd		Language	es-ES
Approved By	1st View	Version	Sheet 2 - 4	

# Bloques de programa

## STW\_PALABRA\_DE\_MANDO\_DB [DB1]

### STW\_PALABRA\_DE\_MANDO\_DB Propiedades

#### General

Nombre	STW_PALABRA_DE_MANDO_DB	Número	1
Tipo	DB	Idioma	DB
Numeración	automática		

#### Información

Título		Autor	
Comentario		Familia	
Versión	0.1	ID personalizada	

Nombre	Tipo de datos	Valor de arranque	Remanencia	Accesible desde HMI	Visible en HMI	Valor de ajuste	Comentario
▼ Input							
ON_OFF1	Bool	false	False	True	True	False	
OFF2	Bool	TRUE	False	True	True	False	
OFF3	Bool	TRUE	False	True	True	False	
REVERSING	Bool	false	False	True	True	False	
▼ Output							
STW_PALABRA_DE_MANDO	Word	16#0	False	True	True	False	
DIR_STW	UDInt	0	False	True	True	False	
InOut							
▼ Static							
PULSE_ENABLE	Bool	TRUE	False	True	True	False	
RFG_ENABLE	Bool	TRUE	False	True	True	False	
RFG_START	Bool	TRUE	False	True	True	False	
ENABLE_SET-POINT	Bool	TRUE	False	True	True	False	
ERROR_ACK	Bool	false	False	True	True	False	
JOG_RIGHT	Bool	false	False	True	True	False	
JOG_LEFT	Bool	false	False	True	True	False	
CONTROL_OF_AG	Bool	TRUE	False	True	True	False	
GUION	Bool	false	False	True	True	False	
MOTOR_P_HIGHER	Bool	false	False	True	True	False	
MOTOR_P_LOWER	Bool	false	False	True	True	False	
MANUAL_AUTO	Bool	false	False	True	True	False	
STW	Word	16#0	False	True	True	False	

Owner	Project name	MODBUS_S7-1200_SINAMICS_V20_V13_SP1	Date	12/09/2017	
	Operator	Project path C:\Users\integradora\Desktop\TESIS MODBUS\Documentos\S7 1200 - V20 MODBUS RS232\MODBUS_S7-1200_SINAMICS_V20_V13_SP1			
Designed By	Location				
Checked By	Description 1st		Language		es-ES
Approved By	Description 2nd		1st View		Version
Sheet 3 - 1					

# Bloques de programa

## HSW\_CONSIGNA\_DE\_VELOCIDAD [FB2]

### HSW\_CONSIGNA\_DE\_VELOCIDAD Propiedades

#### General

Nombre	HSW_CONSIGNA_DE_VELOCIDAD	Número	2
Tipo	FB	Idioma	KOP
Numeración	automática		

#### Información

Título	HSW_CONSIGNA_DE_VELOCIDAD	Autor	
Comentario		Familia	
Versión	0.1	ID personalizada	

Nombre	Tipo de datos	Valor predet.	Remanencia	Accesible desde HMI	Visible en HMI	Valor de ajuste	Comentario
▼ Input							
VELOCIDAD_DESEADA	Real	0.0	No remanente	True	True	False	
▼ Output							
HSW_VELOCIDAD	Word	16#0	No remanente	True	True	False	
DIR_HSW	UDInt	0	No remanente	True	True	False	
▼ InOut							
VELOCIDAD_CONV	Real	0.0	No remanente	True	True	False	
Static							
Temp							
Constant							

### Segmento 1: INGRESO DE VELOCIDAD DESEADA EN HZ

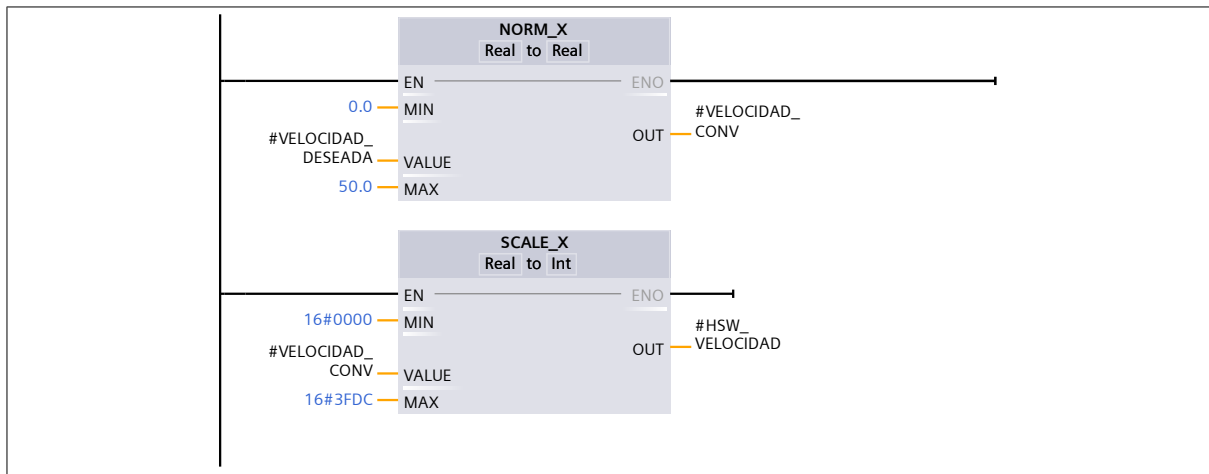

Owner	Project name	MODBUS_S7-1200_SINAMICS_V20_V13_SP1	Date	12/09/2017
Operator	Project path	C:\Users\integradora\Desktop\TESIS MODBUS\Documentos\S7 1200 - V20 MODBUS RS232\MODBUS_S7-1200_SINAMICS_V20_V13_SP1		
Designed By	Description 1st			
Checked By	Description 2nd	Language	es-ES	
Approved By	1st View	Version	Sheet 4 - 1	

Símbolo	Dirección	Tipo	Comentario
#HSW_VELOCIDAD		Word	
#VELOCIDAD_CONV		Real	
#VELOCIDAD_DESEADA		Real	

### Segmento 2: DIRECCIONAMIENTO

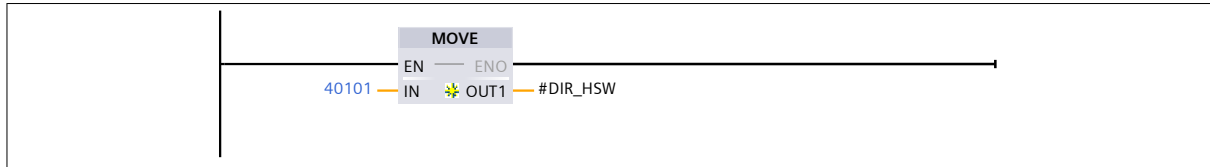

Símbolo	Dirección	Tipo	Comentario
#DIR_HSW		UDInt	

Owner	Project name	MODBUS_S7-1200_SINAMICS_V20_V13_SP1	Date	12/09/2017
	Operator	Project path C:\Users\integradora\Desktop\TESIS MODBUS\Documentos\S7 1200 - V20 MODBUS RS232\MODBUS_S7-1200_SINAMICS_V20_V13_SP1		
Designed By	Location			
Checked By	Description 1st	Language es-ES		
Approved By	Description 2nd	1st View	Version	Sheet 4 - 2

# Bloques de programa

## HSW\_CONSIGNA\_DE\_VELOCIDAD\_DB [DB2]

### HSW\_CONSIGNA\_DE\_VELOCIDAD\_DB Propiedades

#### General

Nombre	HSW_CONSIGNA_DE_VELOCIDAD_DB	Número	2
Tipo	DB	Idioma	DB
Numeración	automática		

#### Información

Título		Autor	
Comentario		Familia	
Versión	0.1	ID personalizada	

Nombre	Tipo de datos	Valor de arranque	Remanencia	Accesible desde HMI	Visible en HMI	Valor de ajuste	Comentario
▼ Input							
VELOCIDAD_DESEADA	Real	0.0	False	True	True	False	
▼ Output							
HSW_VELOCIDAD	Word	16#0	False	True	True	False	
DIR_HSW	UDInt	0	False	True	True	False	
▼ InOut							
VELOCIDAD_CONV	Real	0.0	False	True	True	False	
Static							

Owner	Project name	MODBUS_S7-1200_SINAMICS_V20_V13_SP1	Date	12/09/2017
Operator	Project path	C:\Users\integradora\Desktop\TESIS MODBUS\Documentos\S7 1200 - V20 MODBUS RS232\MODBUS_S7-1200_SINAMICS_V20_V13_SP1		
Designed By	Description 1st			
Checked By	Description 2nd	Language	es-ES	
Approved By	1st View	Version	Sheet 5 - 1	



# Bloques de programa / Bloques de sistema / Recursos de programa

## MB\_COMM\_LOAD\_DB [DB3]

### MB\_COMM\_LOAD\_DB Propiedades

#### General

Nombre	MB_COMM_LOAD_DB	Número	3
Tipo	DB	Idioma	DB
Numeración	automática		

#### Información

Título		Autor	SIMATIC
Comentario		Familia	MODBUS
Versión	2.1	ID personalizada	MB_CM_LD

Nombre	Tipo de datos	Valor de arranque	Remanencia	Accesible desde HMI	Visible en HMI	Valor de ajuste	Comentario
▼ Input							
REQ	Bool	FALSE	False	True	True	False	The enable to initiate a Modbus configuration operation
PORT	PORT	16#FFFF	False	True	True	False	The PtP hardware address
BAUD	UDInt	0	False	True	True	False	The baud rate of the PtP port
PARITY	UInt	0	False	True	True	False	The parity of the PtP port
FLOW_CTRL	UInt	0	False	True	True	False	Transmit and receive flow control
RTS_ON_DLY	UInt	0	False	True	True	False	The enable time of RTS before sending the first character
RTS_OFF_DLY	UInt	0	False	True	True	False	The enable time of RTS after sending the last character
RESP_TO	UInt	1000	False	True	True	False	The time to wait for the Modbus slave to respond
▼ Output							
DONE	Bool	FALSE	False	True	True	False	Boolean indicating completion without error
ERROR	Bool	FALSE	False	True	True	False	Boolean indicating completion with error
STATUS	Word	W#16#0	False	True	True	False	Status of the current operation
▼ InOut							
MB_DB	MB_BASE		False	False	False	False	The instance DB of the Modbus master or slave
▼ Static							
ICHAR_GAP	UInt	0	False	True	True	False	

Owner	Project name	MODBUS_S7-1200_SINAMICS_V20_V13_SP1	Date	12/09/2017
Operator	Project path	C:\Users\integradora\Desktop\TESIS MODBUS\Documentos\S7 1200 - V20 MODBUS RS232\MODBUS_S7-1200_SINAMICS_V20_V13_SP1		
Designed By	Description 1st			
Checked By	Description 2nd	Language	es-ES	
Approved By	1st View	Version	Sheet 6 - 1	

A

Nombre	Tipo de datos	Valor de arranque	Remanencia	Accesible desde HMI	Visible en HMI	Valor de ajuste	Comentario
RETRIES	UInt	2	False	True	True	False	
WRREC_STATUS	Word	2	False	True	True	False	
RDREC_STATUS	Word	2	False	True	True	False	
SFC_STATUS	Word	2	False	True	True	False	
▼ Port_CFG_SFB	Array[0..25] of Byte		False	False	False	False	
Port_CFG_SFB[0]	Byte	16#0	False	False	False	False	
Port_CFG_SFB[1]	Byte	16#0	False	False	False	False	
Port_CFG_SFB[2]	Byte	16#0	False	False	False	False	
Port_CFG_SFB[3]	Byte	16#0	False	False	False	False	
Port_CFG_SFB[4]	Byte	16#0	False	False	False	False	
Port_CFG_SFB[5]	Byte	16#0	False	False	False	False	
Port_CFG_SFB[6]	Byte	16#0	False	False	False	False	
Port_CFG_SFB[7]	Byte	16#0	False	False	False	False	
Port_CFG_SFB[8]	Byte	16#0	False	False	False	False	
Port_CFG_SFB[9]	Byte	16#0	False	False	False	False	
Port_CFG_SFB[10]	Byte	16#0	False	False	False	False	
Port_CFG_SFB[11]	Byte	16#0	False	False	False	False	
Port_CFG_SFB[12]	Byte	16#0	False	False	False	False	
Port_CFG_SFB[13]	Byte	16#0	False	False	False	False	
Port_CFG_SFB[14]	Byte	16#0	False	False	False	False	
Port_CFG_SFB[15]	Byte	16#0	False	False	False	False	
Port_CFG_SFB[16]	Byte	16#0	False	False	False	False	
Port_CFG_SFB[17]	Byte	16#0	False	False	False	False	
Port_CFG_SFB[18]	Byte	16#0	False	False	False	False	
Port_CFG_SFB[19]	Byte	16#0	False	False	False	False	

B

C

D

E

F

Owner	Project name	MODBUS_S7-1200_SINAMICS_V20_V13_SP1	Date	12/09/2017
Operator	Project path	C:\Users\integradora\Desktop\TESIS MODBUS\Documentos\S7 1200 - V20 MODBUS RS232\MODBUS_S7-1200_SINAMICS_V20_V13_SP1		
Designed By	Description 1st			
Checked By	Description 2nd	Language	es-ES	
Approved By	1st View	Version	Sheet 6 - 2	

1

2

3

4

A

Nombre	Tipo de datos	Valor de arranque	Remanencia	Accesible desde HMI	Visible en HMI	Valor de ajuste	Comentario
Port_CFG_SFB[20]	Byte	16#0	False	False	False	False	
Port_CFG_SFB[21]	Byte	16#0	False	False	False	False	
Port_CFG_SFB[22]	Byte	16#0	False	False	False	False	
Port_CFG_SFB[23]	Byte	16#0	False	False	False	False	
Port_CFG_SFB[24]	Byte	16#0	False	False	False	False	
Port_CFG_SFB[25]	Byte	16#0	False	False	False	False	
▼ Send_CFG_SFB	Array[0..16] of Byte		False	False	False	False	
Send_CFG_SFB[0]	Byte	16#0	False	False	False	False	
Send_CFG_SFB[1]	Byte	16#0	False	False	False	False	
Send_CFG_SFB[2]	Byte	16#0	False	False	False	False	
Send_CFG_SFB[3]	Byte	16#0	False	False	False	False	
Send_CFG_SFB[4]	Byte	16#0	False	False	False	False	
Send_CFG_SFB[5]	Byte	16#0	False	False	False	False	
Send_CFG_SFB[6]	Byte	16#0	False	False	False	False	
Send_CFG_SFB[7]	Byte	16#0	False	False	False	False	
Send_CFG_SFB[8]	Byte	16#0	False	False	False	False	
Send_CFG_SFB[9]	Byte	16#0	False	False	False	False	
Send_CFG_SFB[10]	Byte	16#0	False	False	False	False	
Send_CFG_SFB[11]	Byte	16#0	False	False	False	False	
Send_CFG_SFB[12]	Byte	16#0	False	False	False	False	
Send_CFG_SFB[13]	Byte	16#0	False	False	False	False	
Send_CFG_SFB[14]	Byte	16#0	False	False	False	False	
Send_CFG_SFB[15]	Byte	16#0	False	False	False	False	
Send_CFG_SFB[16]	Byte	16#0	False	False	False	False	

B

C

D

E

F

Owner	Project name	MODBUS_S7-1200_SINAMICS_V20_V13_SP1	Date	12/09/2017
Operator	Project path	C:\Users\integradora\Desktop\TESIS MODBUS\Documentos\S7 1200 - V20 MODBUS RS232\MODBUS_S7-1200_SINAMICS_V20_V13_SP1		
Designed By	Description 1st			
Checked By	Description 2nd	Language	es-ES	
Approved By	1st View	Version	Sheet 6 - 3	

1

2

3

4

A

Nombre	Tipo de datos	Valor de arranque	Remanencia	Accesible desde HMI	Visible en HMI	Valor de ajuste	Comentario
▼ Rcv_CFG_SFB	Array[0..60] of Byte		False	False	False	False	
Rcv_CFG_SFB[0]	Byte	16#0	False	False	False	False	
Rcv_CFG_SFB[1]	Byte	16#0	False	False	False	False	
Rcv_CFG_SFB[2]	Byte	16#0	False	False	False	False	
Rcv_CFG_SFB[3]	Byte	16#0	False	False	False	False	
Rcv_CFG_SFB[4]	Byte	16#0	False	False	False	False	
Rcv_CFG_SFB[5]	Byte	16#0	False	False	False	False	
Rcv_CFG_SFB[6]	Byte	16#0	False	False	False	False	
Rcv_CFG_SFB[7]	Byte	16#0	False	False	False	False	
Rcv_CFG_SFB[8]	Byte	16#0	False	False	False	False	
Rcv_CFG_SFB[9]	Byte	16#0	False	False	False	False	
Rcv_CFG_SFB[10]	Byte	16#0	False	False	False	False	
Rcv_CFG_SFB[11]	Byte	16#0	False	False	False	False	
Rcv_CFG_SFB[12]	Byte	16#0	False	False	False	False	
Rcv_CFG_SFB[13]	Byte	16#0	False	False	False	False	
Rcv_CFG_SFB[14]	Byte	16#0	False	False	False	False	
Rcv_CFG_SFB[15]	Byte	16#0	False	False	False	False	
Rcv_CFG_SFB[16]	Byte	16#0	False	False	False	False	
Rcv_CFG_SFB[17]	Byte	16#0	False	False	False	False	
Rcv_CFG_SFB[18]	Byte	16#0	False	False	False	False	
Rcv_CFG_SFB[19]	Byte	16#0	False	False	False	False	
Rcv_CFG_SFB[20]	Byte	16#0	False	False	False	False	
Rcv_CFG_SFB[21]	Byte	16#0	False	False	False	False	
Rcv_CFG_SFB[22]	Byte	16#0	False	False	False	False	

B

C

D

E

F

Owner	Project name	MODBUS_S7-1200_SINAMICS_V20_V13_SP1	Date	12/09/2017
Operator	Project path	C:\Users\integradora\Desktop\TESIS MODBUS\Documentos\S7 1200 - V20 MODBUS RS232\MODBUS_S7-1200_SINAMICS_V20_V13_SP1		
Designed By	Description 1st			
Checked By	Description 2nd	Language	es-ES	
Approved By	1st View	Version	Sheet 6 - 4	

1

2

3

4

A

Nombre	Tipo de datos	Valor de arranque	Remanencia	Accesible desde HMI	Visible en HMI	Valor de ajuste	Comentario
Rcv_CFG_SFB[2 3]	Byte	16#0	False	False	False	False	
Rcv_CFG_SFB[2 4]	Byte	16#0	False	False	False	False	
Rcv_CFG_SFB[2 5]	Byte	16#0	False	False	False	False	
Rcv_CFG_SFB[2 6]	Byte	16#0	False	False	False	False	
Rcv_CFG_SFB[2 7]	Byte	16#0	False	False	False	False	
Rcv_CFG_SFB[2 8]	Byte	16#0	False	False	False	False	
Rcv_CFG_SFB[2 9]	Byte	16#0	False	False	False	False	
Rcv_CFG_SFB[3 0]	Byte	16#0	False	False	False	False	
Rcv_CFG_SFB[3 1]	Byte	16#0	False	False	False	False	
Rcv_CFG_SFB[3 2]	Byte	16#0	False	False	False	False	
Rcv_CFG_SFB[3 3]	Byte	16#0	False	False	False	False	
Rcv_CFG_SFB[3 4]	Byte	16#0	False	False	False	False	
Rcv_CFG_SFB[3 5]	Byte	16#0	False	False	False	False	
Rcv_CFG_SFB[3 6]	Byte	16#0	False	False	False	False	
Rcv_CFG_SFB[3 7]	Byte	16#0	False	False	False	False	
Rcv_CFG_SFB[3 8]	Byte	16#0	False	False	False	False	
Rcv_CFG_SFB[3 9]	Byte	16#0	False	False	False	False	
Rcv_CFG_SFB[4 0]	Byte	16#0	False	False	False	False	
Rcv_CFG_SFB[4 1]	Byte	16#0	False	False	False	False	
Rcv_CFG_SFB[4 2]	Byte	16#0	False	False	False	False	
Rcv_CFG_SFB[4 3]	Byte	16#0	False	False	False	False	
Rcv_CFG_SFB[4 4]	Byte	16#0	False	False	False	False	
Rcv_CFG_SFB[4 5]	Byte	16#0	False	False	False	False	
Rcv_CFG_SFB[4 6]	Byte	16#0	False	False	False	False	

C

D

E

F

Owner	Project name	MODBUS_S7-1200_SINAMICS_V20_V13_SP1	Date	12/09/2017
Operator	Project path	C:\Users\integradora\Desktop\TESIS MODBUS\Documentos\S7 1200 - V20 MODBUS RS232\MODBUS_S7-1200_SINAMICS_V20_V13_SP1		
Designed By	Description 1st			
Checked By	Description 2nd	Language	es-ES	
Approved By	1st View	Version	Sheet 6 - 5	

1

2

3

4

A

Nombre	Tipo de datos	Valor de arranque	Remanencia	Accesible desde HMI	Visible en HMI	Valor de ajuste	Comentario
Rcv_CFG_SFB[4 7]	Byte	16#0	False	False	False	False	
Rcv_CFG_SFB[4 8]	Byte	16#0	False	False	False	False	
Rcv_CFG_SFB[4 9]	Byte	16#0	False	False	False	False	
Rcv_CFG_SFB[5 0]	Byte	16#0	False	False	False	False	
Rcv_CFG_SFB[5 1]	Byte	16#0	False	False	False	False	
Rcv_CFG_SFB[5 2]	Byte	16#0	False	False	False	False	
Rcv_CFG_SFB[5 3]	Byte	16#0	False	False	False	False	
Rcv_CFG_SFB[5 4]	Byte	16#0	False	False	False	False	
Rcv_CFG_SFB[5 5]	Byte	16#0	False	False	False	False	
Rcv_CFG_SFB[5 6]	Byte	16#0	False	False	False	False	
Rcv_CFG_SFB[5 7]	Byte	16#0	False	False	False	False	
Rcv_CFG_SFB[5 8]	Byte	16#0	False	False	False	False	
Rcv_CFG_SFB[5 9]	Byte	16#0	False	False	False	False	
Rcv_CFG_SFB[6 0]	Byte	16#0	False	False	False	False	
STOP_BITS	USInt	1	False	True	True	False	

B

C

D

E

F

Owner	Project name	MODBUS_S7-1200_SINAMICS_V20_V13_SP1	Date	12/09/2017
Operator	Project path	C:\Users\integradora\Desktop\TESIS MODBUS\Documentos\S7 1200 - V20 MODBUS RS232\MODBUS_S7-1200_SINAMICS_V20_V13_SP1		
Designed By	Description 1st	Location		
Checked By	Description 2nd	Language	es-ES	
Approved By	1st View	Version	Sheet 6 - 6	

# Bloques de programa / Bloques de sistema / Recursos de programa

## MB\_MASTER\_DB [DB4]

### MB\_MASTER\_DB Propiedades

#### General

Nombre	MB_MASTER_DB	Número	4
Tipo	DB	Idioma	DB
Numeración	automática		

#### Información

Título		Autor	SIMATIC
Comentario		Familia	MODBUS
Versión	2.2	ID personalizada	MB_MASTR

Nombre	Tipo de datos	Valor de arranque	Remanencia	Accesible desde HMI	Visible en HMI	Valor de ajuste	Comentario
▼ Base	MB_BASE		False	True	True	False	
Input							
Output							
InOut							
▼ Static							
S_PORT	UInt	16#FFFF	False	False	False	False	
S_RESP_TO	UInt	1000	False	False	False	False	
S_ICHAR_GAP	UInt	28	False	False	False	False	
S_RETRIES	UInt	2	False	False	False	False	
▼ Input							
REQ	Bool	FALSE	False	True	True	False	The enable to initiate a Modbus master request
MB_ADDR	UInt	0	False	True	True	False	The station address of the Modbus slave
MODE	USInt	0	False	True	True	False	Specifies a read, write, or diagnostic operation
DATA_ADDR	UDInt	0	False	True	True	False	The Modbus data address
DATA_LEN	UInt	0	False	True	True	False	The Modbus data length
▼ Output							
DONE	Bool	FALSE	False	True	True	False	Boolean indicating completion without error
BUSY	Bool	FALSE	False	True	True	False	Boolean indicating operation in progress
ERROR	Bool	FALSE	False	True	True	False	Boolean indicating completion with error
STATUS	Word	W#16#0	False	True	True	False	Status or error code of the completed operation
▼ InOut							

Owner	Project name	MODBUS_S7-1200_SINAMICS_V20_V13_SP1	Date	12/09/2017
Operator	Project path	C:\Users\integradora\Desktop\TESIS MODBUS\Documentos\S7 1200 - V20 MODBUS RS232\MODBUS_S7-1200_SINAMICS_V20_V13_SP1		
Designed By	Description 1st			
Checked By	Description 2nd	Language	es-ES	
Approved By	1st View	Version	Sheet 7 - 1	

A

Nombre	Tipo de datos	Valor de arranque	Remanencia	Accesible desde HMI	Visible en HMI	Valor de ajuste	Comentario
DATA_PTR	Variant		False	False	False	False	Data area used to communicate with the Modbus slave
▼ Static							
▼ SEND_PTP_SFB	Array[0..11] of Byte		False	False	False	False	
SEND_PTP_SFB[0]	Byte	16#0	False	False	False	False	
SEND_PTP_SFB[1]	Byte	16#0	False	False	False	False	
SEND_PTP_SFB[2]	Byte	16#0	False	False	False	False	
SEND_PTP_SFB[3]	Byte	16#0	False	False	False	False	
SEND_PTP_SFB[4]	Byte	16#0	False	False	False	False	
SEND_PTP_SFB[5]	Byte	16#0	False	False	False	False	
SEND_PTP_SFB[6]	Byte	16#0	False	False	False	False	
SEND_PTP_SFB[7]	Byte	16#0	False	False	False	False	
SEND_PTP_SFB[8]	Byte	16#0	False	False	False	False	
SEND_PTP_SFB[9]	Byte	16#0	False	False	False	False	
SEND_PTP_SFB[10]	Byte	16#0	False	False	False	False	
SEND_PTP_SFB[11]	Byte	16#0	False	False	False	False	
▼ RCV_PTP_SFB	Array[0..11] of Byte		False	False	False	False	
RCV_PTP_SFB[0]	Byte	16#0	False	False	False	False	
RCV_PTP_SFB[1]	Byte	16#0	False	False	False	False	
RCV_PTP_SFB[2]	Byte	16#0	False	False	False	False	
RCV_PTP_SFB[3]	Byte	16#0	False	False	False	False	
RCV_PTP_SFB[4]	Byte	16#0	False	False	False	False	
RCV_PTP_SFB[5]	Byte	16#0	False	False	False	False	
RCV_PTP_SFB[6]	Byte	16#0	False	False	False	False	

B

C

D

E

F

Owner	Project name	MODBUS_S7-1200_SINAMICS_V20_V13_SP1	Date	12/09/2017
Operator	Project path	C:\Users\integradora\Desktop\TESIS MODBUS\Documentos\S7 1200 - V20 MODBUS RS232\MODBUS_S7-1200_SINAMICS_V20_V13_SP1		
Designed By	Description 1st			
Checked By	Description 2nd	Language	es-ES	
Approved By	1st View	Version	Sheet 7 - 2	



A

B

C

D

E

F

Nombre	Tipo de datos	Valor de arranque	Remanencia	Accesible desde HMI	Visible en HMI	Valor de ajuste	Comentario
RCV_PTP_SFB[7]	Byte	16#0	False	False	False	False	
RCV_PTP_SFB[8]	Byte	16#0	False	False	False	False	
RCV_PTP_SFB[9]	Byte	16#0	False	False	False	False	
RCV_PTP_SFB[10]	Byte	16#0	False	False	False	False	
RCV_PTP_SFB[11]	Byte	16#0	False	False	False	False	
▼ RCV_RST_SFB	Array[0..9] of Byte		False	False	False	False	
RCV_RST_SFB[0]	Byte	16#0	False	False	False	False	
RCV_RST_SFB[1]	Byte	16#0	False	False	False	False	
RCV_RST_SFB[2]	Byte	16#0	False	False	False	False	
RCV_RST_SFB[3]	Byte	16#0	False	False	False	False	
RCV_RST_SFB[4]	Byte	16#0	False	False	False	False	
RCV_RST_SFB[5]	Byte	16#0	False	False	False	False	
RCV_RST_SFB[6]	Byte	16#0	False	False	False	False	
RCV_RST_SFB[7]	Byte	16#0	False	False	False	False	
RCV_RST_SFB[8]	Byte	16#0	False	False	False	False	
RCV_RST_SFB[9]	Byte	16#0	False	False	False	False	
PF_FREQUENCY	Real	0.0	False	False	False	False	
BLOCKED_PROC_TIMEOUT	Real	3.0	False	True	True	False	
CURRENT_TIME_VALUE	UDInt	0	False	False	False	False	
SAVED_TIME_VALUE	UDInt	0	False	False	False	False	
SAVED_SLAVE_ADDR	Word	0	False	False	False	False	
SAVED_MODE	Word	0	False	False	False	False	
SAVED_DATA_ADDR	DWord	0	False	False	False	False	
SAVED_DATA_LEN	UInt	0	False	False	False	False	
MB_STATE	UInt	0	False	False	False	False	

Owner	Project name	MODBUS_S7-1200_SINAMICS_V20_V13_SP1	Date	12/09/2017
Operator	Project path	C:\Users\integradora\Desktop\TESIS MODBUS\Documentos\S7 1200 - V20 MODBUS RS232\MODBUS_S7-1200_SINAMICS_V20_V13_SP1		
Designed By	Description 1st			
Checked By	Description 2nd	Language	es-ES	
Approved By	1st View	Version	Sheet 7 - 3	

1

2

3

4

A

Nombre	Tipo de datos	Valor de arranque	Remanencia	Accesible desde HMI	Visible en HMI	Valor de ajuste	Comentario
COMM_SENT_COUNT	UInt	0	False	False	False	False	
BYTE_COUNT	UInt	0	False	False	False	False	
INIT_OK	Bool	FALSE	False	False	False	False	
ACTIVE	Bool	FALSE	False	False	False	False	
BROADCAST_FLAG	Bool	FALSE	False	False	False	False	
EXTENDED_ADDRESSING	Bool	FALSE	False	True	True	False	
SAVED_START_ADDR	UInt	0	False	False	False	False	
TXBuf_Function_Offset	UDInt	0	False	False	False	False	
TXBuf_Address_Offset	UDInt	0	False	False	False	False	
TXBuf_Quantity_Offset	UDInt	0	False	False	False	False	

B

C

D

E

F

Owner	Project name	MODBUS_S7-1200_SINAMICS_V20_V13_SP1	Date	12/09/2017
Operator	Project path	C:\Users\integradora\Desktop\TESIS MODBUS\Documentos\S7 1200 - V20 MODBUS RS232\MODBUS_S7-1200_SINAMICS_V20_V13_SP1		
	Location			
Designed By	Description 1st			
Checked By	Description 2nd	Language	es-ES	
Approved By	1st View	Version	Sheet 7 - 4	

# Bloques de programa / Bloques de sistema / Recursos de programa

## MB\_MASTER [FB1081]

### MB\_MASTER Propiedades

#### General

Nombre	MB_MASTER	Número	1081
Tipo	FB	Idioma	KOP
Numeración	automática		

#### Información

Título		Autor	SIMATIC
Comentario		Familia	MODBUS
Versión	2.2	ID personalizada	MB_MASTR

Nombre	Tipo de datos	Valor predet.	Remanencia	Accesible desde HMI	Visible en HMI	Valor de ajuste	Comentario
▼ Base	MB_BASE			True	True	False	
Input							
Output							
InOut							
▼ Static							
S_PORT	UInt	16#FFFF	No remanente	False	False	False	
S_RESP_TO	UInt	1000	No remanente	False	False	False	
S_ICHAR_GAP	UInt	28	No remanente	False	False	False	
S_RETRIES	UInt	2	No remanente	False	False	False	
▼ Input							
REQ	Bool	FALSE	No remanente	True	True	False	The enable to initiate a Modbus master request
MB_ADDR	UInt	0	No remanente	True	True	False	The station address of the Modbus slave
MODE	USInt	0	No remanente	True	True	False	Specifies a read, write, or diagnostic operation
DATA_ADDR	UDInt	0	No remanente	True	True	False	The Modbus data address
DATA_LEN	UInt	0	No remanente	True	True	False	The Modbus data length
▼ Output							
DONE	Bool	FALSE	No remanente	True	True	False	Boolean indicating completion without error
BUSY	Bool	FALSE	No remanente	True	True	False	Boolean indicating operation in progress

Owner	Project name	MODBUS_S7-1200_SINAMICS_V20_V13_SP1	Date	12/09/2017
Operator	Project path	C:\Users\integradora\Desktop\TESIS MODBUS\Documentos\S7 1200 - V20 MODBUS RS232\MODBUS_S7-1200_SINAMICS_V20_V13_SP1		
Designed By	Description 1st			
Checked By	Description 2nd	Language	es-ES	
Approved By	1st View	Version	Sheet 8 - 1	

A

Nombre	Tipo de datos	Valor predet.	Remanencia	Accesible desde HMI	Visible en HMI	Valor de ajuste	Comentario
ERROR	Bool	FALSE	No remanente	True	True	False	Boolean indicating completion with error
STATUS	Word	W#16#0	No remanente	True	True	False	Status or error code of the completed operation
▼ InOut							
DATA_PTR	Variant			False	False	False	Data area used to communicate with the Modbus slave
▼ Static							
▼ SEND_PTP_SFB							
SEND_PTP_SFB[0]	Array[0..11] of Byte		No remanente	False	False	False	
SEND_PTP_SFB[1]	Byte	16#0	No remanente	False	False	False	
SEND_PTP_SFB[2]	Byte	16#0	No remanente	False	False	False	
SEND_PTP_SFB[3]	Byte	16#0	No remanente	False	False	False	
SEND_PTP_SFB[4]	Byte	16#0	No remanente	False	False	False	
SEND_PTP_SFB[5]	Byte	16#0	No remanente	False	False	False	
SEND_PTP_SFB[6]	Byte	16#0	No remanente	False	False	False	
SEND_PTP_SFB[7]	Byte	16#0	No remanente	False	False	False	
SEND_PTP_SFB[8]	Byte	16#0	No remanente	False	False	False	
SEND_PTP_SFB[9]	Byte	16#0	No remanente	False	False	False	
SEND_PTP_SFB[10]	Byte	16#0	No remanente	False	False	False	
SEND_PTP_SFB[11]	Byte	16#0	No remanente	False	False	False	
▼ RCV_PTP_SFB							
RCV_PTP_SFB[0]	Array[0..11] of Byte		No remanente	False	False	False	
RCV_PTP_SFB[1]	Byte	16#0	No remanente	False	False	False	
RCV_PTP_SFB[2]	Byte	16#0	No remanente	False	False	False	
RCV_PTP_SFB[3]	Byte	16#0	No remanente	False	False	False	

B

C

D

E

F

Owner	Project name	MODBUS_S7-1200_SINAMICS_V20_V13_SP1	Date	12/09/2017
Operator	Project path	C:\Users\integradora\Desktop\TESIS MODBUS\Documentos\S7 1200 - V20 MODBUS RS232\MODBUS_S7-1200_SINAMICS_V20_V13_SP1		
Designed By	Description 1st			
Checked By	Description 2nd	Language	es-ES	
Approved By	1st View	Version	Sheet 8 - 2	

A

B

C

D

E

F

Nombre	Tipo de datos	Valor predet.	Remanencia	Accesible desde HMI	Visible en HMI	Valor de ajuste	Comentario
RCV_PTP_SFB[4]	Byte	16#0	No remanente	False	False	False	
RCV_PTP_SFB[5]	Byte	16#0	No remanente	False	False	False	
RCV_PTP_SFB[6]	Byte	16#0	No remanente	False	False	False	
RCV_PTP_SFB[7]	Byte	16#0	No remanente	False	False	False	
RCV_PTP_SFB[8]	Byte	16#0	No remanente	False	False	False	
RCV_PTP_SFB[9]	Byte	16#0	No remanente	False	False	False	
RCV_PTP_SFB[10]	Byte	16#0	No remanente	False	False	False	
RCV_PTP_SFB[11]	Byte	16#0	No remanente	False	False	False	
▼ RCV_RST_SFB	Array[0..9] of Byte		No remanente	False	False	False	
RCV_RST_SFB[0]	Byte	16#0	No remanente	False	False	False	
RCV_RST_SFB[1]	Byte	16#0	No remanente	False	False	False	
RCV_RST_SFB[2]	Byte	16#0	No remanente	False	False	False	
RCV_RST_SFB[3]	Byte	16#0	No remanente	False	False	False	
RCV_RST_SFB[4]	Byte	16#0	No remanente	False	False	False	
RCV_RST_SFB[5]	Byte	16#0	No remanente	False	False	False	
RCV_RST_SFB[6]	Byte	16#0	No remanente	False	False	False	
RCV_RST_SFB[7]	Byte	16#0	No remanente	False	False	False	
RCV_RST_SFB[8]	Byte	16#0	No remanente	False	False	False	
RCV_RST_SFB[9]	Byte	16#0	No remanente	False	False	False	
PF_FREQUENCY	Real	0.0	No remanente	False	False	False	
BLOCKED_PROC_TIMEOUT	Real	3.0	No remanente	True	True	False	
CURRENT_TIME_VALUE	UDInt	0	No remanente	False	False	False	
SAVED_TIME_VALUE	UDInt	0	No remanente	False	False	False	
SAVED_SLAVE_ADDR	Word	0	No remanente	False	False	False	

Owner	Project name	MODBUS_S7-1200_SINAMICS_V20_V13_SP1	Date	12/09/2017
Operator	Project path	C:\Users\integradora\Desktop\TESIS MODBUS\Documentos\S7 1200 - V20 MODBUS RS232\MODBUS_S7-1200_SINAMICS_V20_V13_SP1		
Designed By	Description 1st			
Checked By	Description 2nd	Language	es-ES	
Approved By	1st View	Version	Sheet 8 - 3	

Nombre	Tipo de datos	Valor predet.	Remanencia	Accesible desde HMI	Visible en HMI	Valor de ajuste	Comentario
SAVED_MODE	Word	0	No remanente	False	False	False	
SAVED_DATA_ADDR	DWord	0	No remanente	False	False	False	
SAVED_DATA_LEN	UInt	0	No remanente	False	False	False	
MB_STATE	UInt	0	No remanente	False	False	False	
COMM_SENT_COUNT	UInt	0	No remanente	False	False	False	
BYTE_COUNT	USInt	0	No remanente	False	False	False	
INIT_OK	Bool	FALSE	No remanente	False	False	False	
ACTIVE	Bool	FALSE	No remanente	False	False	False	
BROADCAST_FLAG	Bool	FALSE	No remanente	False	False	False	
EXTENDED_ADDRESSING	Bool	FALSE	No remanente	True	True	False	
SAVED_START_ADDR	UInt	0	No remanente	False	False	False	
TXBuf_Function_Offset	UDInt	0	No remanente	False	False	False	
TXBuf_Address_Offset	UDInt	0	No remanente	False	False	False	
TXBuf_Quantity_Offset	UDInt	0	No remanente	False	False	False	

Owner	Project name	MODBUS_S7-1200_SINAMICS_V20_V13_SP1	Date	12/09/2017
	Operator	Project path	C:\Users\integradora\Desktop\TESIS MODBUS\Documentos\S7 1200 - V20 MODBUS RS232\MODBUS_S7-1200_SINAMICS_V20_V13_SP1	
Designed By		Location		
	Description 1st			
Checked By	Description 2nd		Language	es-ES
	Approved By	1st View		Version
Sheet 8 - 4				

# Bloques de programa / Bloques de sistema / Recursos de programa

## MB\_COMM\_LOAD [FB1080]

### MB\_COMM\_LOAD Propiedades

#### General

Nombre	MB_COMM_LOAD	Número	1080
Tipo	FB	Idioma	KOP
Numeración	automática		

#### Información

Título		Autor	SIMATIC
Comentario		Familia	MODBUS
Versión	2.1	ID personalizada	MB_CM_LD

Nombre	Tipo de datos	Valor predet.	Remanencia	Accesible desde HMI	Visible en HMI	Valor de ajuste	Comentario
▼ Input							
REQ	Bool	FALSE	No remanente	True	True	False	The enable to initiate a Modbus configuration operation
PORT	PORT	16#FFFF	No remanente	True	True	False	The PtP hardware address
BAUD	UDInt	0	No remanente	True	True	False	The baud rate of the PtP port
PARITY	UInt	0	No remanente	True	True	False	The parity of the PtP port
FLOW_CTRL	UInt	0	No remanente	True	True	False	Transmit and receive flow control
RTS_ON_DLY	UInt	0	No remanente	True	True	False	The enable time of RTS before sending the first character
RTS_OFF_DLY	UInt	0	No remanente	True	True	False	The enable time of RTS after sending the last character
RESP_TO	UInt	1000	No remanente	True	True	False	The time to wait for the Modbus slave to respond
▼ Output							
DONE	Bool	FALSE	No remanente	True	True	False	Boolean indicating completion without error
ERROR	Bool	FALSE	No remanente	True	True	False	Boolean indicating completion with error
STATUS	Word	W#16#0	No remanente	True	True	False	Status of the current operation
▼ InOut							

Owner	Project name	MODBUS_S7-1200_SINAMICS_V20_V13_SP1	Date	12/09/2017
Operator	Project path	C:\Users\integradora\Desktop\TESIS MODBUS\Documentos\S7 1200 - V20 MODBUS RS232\MODBUS_S7-1200_SINAMICS_V20_V13_SP1		
Designed By	Description 1st			
Checked By	Description 2nd	Language	es-ES	
Approved By	1st View	Version	Sheet 9 - 1	

Nombre	Tipo de datos	Valor predet.	Remanencia	Accesible desde HMI	Visible en HMI	Valor de ajuste	Comentario
▼ MB_DB	MB_BASE			False	False	False	The instance DB of the Modbus master or slave
Input							
Output							
InOut							
▼ Static							
S_PORT	UInt	16#FFFF	No remanente	False	False	False	
S_RESP_TO	UInt	1000	No remanente	False	False	False	
S_ICHAR_GA P	UInt	28	No remanente	False	False	False	
S_RETRIES	UInt	2	No remanente	False	False	False	
▼ Static							
ICHAR_GAP	UInt	0	No remanente	True	True	False	
RETRIES	UInt	2	No remanente	True	True	False	
WRREC_STATUS	Word	2	No remanente	True	True	False	
RDREC_STATUS	Word	2	No remanente	True	True	False	
SFC_STATUS	Word	2	No remanente	True	True	False	
▼ Port_CFG_SFB	Ar- ray[0..25] of Byte		No remanente	False	False	False	
Port_CFG_SFB[ 0]	Byte	16#0	No remanente	False	False	False	
Port_CFG_SFB[ 1]	Byte	16#0	No remanente	False	False	False	
Port_CFG_SFB[ 2]	Byte	16#0	No remanente	False	False	False	
Port_CFG_SFB[ 3]	Byte	16#0	No remanente	False	False	False	
Port_CFG_SFB[ 4]	Byte	16#0	No remanente	False	False	False	
Port_CFG_SFB[ 5]	Byte	16#0	No remanente	False	False	False	
Port_CFG_SFB[ 6]	Byte	16#0	No remanente	False	False	False	
Port_CFG_SFB[ 7]	Byte	16#0	No remanente	False	False	False	
Port_CFG_SFB[ 8]	Byte	16#0	No remanente	False	False	False	
Port_CFG_SFB[ 9]	Byte	16#0	No remanente	False	False	False	
Port_CFG_SFB[ 10]	Byte	16#0	No remanente	False	False	False	
Port_CFG_SFB[ 11]	Byte	16#0	No remanente	False	False	False	
Port_CFG_SFB[ 12]	Byte	16#0	No remanente	False	False	False	

Owner	Project name	MODBUS_S7-1200_SINAMICS_V20_V13_SP1	Date	12/09/2017
Operator	Project path	C:\Users\integradora\Desktop\TESIS MODBUS\Documentos\S7 1200 - V20 MODBUS RS232\MODBUS_S7-1200_SINAMICS_V20_V13_SP1		
	Location			
Designed By	Description 1st			
Checked By	Description 2nd	Language	es-ES	
Approved By	1st View	Version	Sheet 9 - 2	



A

B

C

D

E

F

Nombre	Tipo de datos	Valor predet.	Remanencia	Accesible desde HMI	Visible en HMI	Valor de ajuste	Comentario
Port_CFG_SFB[13]	Byte	16#0	No remanente	False	False	False	
Port_CFG_SFB[14]	Byte	16#0	No remanente	False	False	False	
Port_CFG_SFB[15]	Byte	16#0	No remanente	False	False	False	
Port_CFG_SFB[16]	Byte	16#0	No remanente	False	False	False	
Port_CFG_SFB[17]	Byte	16#0	No remanente	False	False	False	
Port_CFG_SFB[18]	Byte	16#0	No remanente	False	False	False	
Port_CFG_SFB[19]	Byte	16#0	No remanente	False	False	False	
Port_CFG_SFB[20]	Byte	16#0	No remanente	False	False	False	
Port_CFG_SFB[21]	Byte	16#0	No remanente	False	False	False	
Port_CFG_SFB[22]	Byte	16#0	No remanente	False	False	False	
Port_CFG_SFB[23]	Byte	16#0	No remanente	False	False	False	
Port_CFG_SFB[24]	Byte	16#0	No remanente	False	False	False	
Port_CFG_SFB[25]	Byte	16#0	No remanente	False	False	False	
▼ Send_CFG_SFB	Array[0..16] of Byte		No remanente	False	False	False	
Send_CFG_SFB[0]	Byte	16#0	No remanente	False	False	False	
Send_CFG_SFB[1]	Byte	16#0	No remanente	False	False	False	
Send_CFG_SFB[2]	Byte	16#0	No remanente	False	False	False	
Send_CFG_SFB[3]	Byte	16#0	No remanente	False	False	False	
Send_CFG_SFB[4]	Byte	16#0	No remanente	False	False	False	
Send_CFG_SFB[5]	Byte	16#0	No remanente	False	False	False	
Send_CFG_SFB[6]	Byte	16#0	No remanente	False	False	False	
Send_CFG_SFB[7]	Byte	16#0	No remanente	False	False	False	
Send_CFG_SFB[8]	Byte	16#0	No remanente	False	False	False	
Send_CFG_SFB[9]	Byte	16#0	No remanente	False	False	False	

Owner	Project name	MODBUS_S7-1200_SINAMICS_V20_V13_SP1	Date	12/09/2017
Operator	Project path	C:\Users\integradora\Desktop\TESIS MODBUS\Documentos\S7 1200 - V20 MODBUS RS232\MODBUS_S7-1200_SINAMICS_V20_V13_SP1		
Designed By	Description 1st			
Checked By	Description 2nd	Language	es-ES	
Approved By	1st View	Version	Sheet 9 - 3	

1

2

3

4

A

Nombre	Tipo de datos	Valor predet.	Remanencia	Accesible desde HMI	Visible en HMI	Valor de ajuste	Comentario
Send_CFG_SF B[10]	Byte	16#0	No remanente	False	False	False	
Send_CFG_SF B[11]	Byte	16#0	No remanente	False	False	False	
Send_CFG_SF B[12]	Byte	16#0	No remanente	False	False	False	
Send_CFG_SF B[13]	Byte	16#0	No remanente	False	False	False	
Send_CFG_SF B[14]	Byte	16#0	No remanente	False	False	False	
Send_CFG_SF B[15]	Byte	16#0	No remanente	False	False	False	
Send_CFG_SF B[16]	Byte	16#0	No remanente	False	False	False	
▼ Rcv_CFG_SFB	Array[0..60] of Byte		No remanente	False	False	False	
Rcv_CFG_SFB[0]	Byte	16#0	No remanente	False	False	False	
Rcv_CFG_SFB[1]	Byte	16#0	No remanente	False	False	False	
Rcv_CFG_SFB[2]	Byte	16#0	No remanente	False	False	False	
Rcv_CFG_SFB[3]	Byte	16#0	No remanente	False	False	False	
Rcv_CFG_SFB[4]	Byte	16#0	No remanente	False	False	False	
Rcv_CFG_SFB[5]	Byte	16#0	No remanente	False	False	False	
Rcv_CFG_SFB[6]	Byte	16#0	No remanente	False	False	False	
Rcv_CFG_SFB[7]	Byte	16#0	No remanente	False	False	False	
Rcv_CFG_SFB[8]	Byte	16#0	No remanente	False	False	False	
Rcv_CFG_SFB[9]	Byte	16#0	No remanente	False	False	False	
Rcv_CFG_SFB[10]	Byte	16#0	No remanente	False	False	False	
Rcv_CFG_SFB[11]	Byte	16#0	No remanente	False	False	False	
Rcv_CFG_SFB[12]	Byte	16#0	No remanente	False	False	False	
Rcv_CFG_SFB[13]	Byte	16#0	No remanente	False	False	False	
Rcv_CFG_SFB[14]	Byte	16#0	No remanente	False	False	False	
Rcv_CFG_SFB[15]	Byte	16#0	No remanente	False	False	False	

B

C

D

E

F

Owner	Project name	MODBUS_S7-1200_SINAMICS_V20_V13_SP1	Date	12/09/2017
Operator	Project path	C:\Users\integradora\Desktop\TESIS MODBUS\Documentos\S7 1200 - V20 MODBUS RS232\MODBUS_S7-1200_SINAMICS_V20_V13_SP1		
Designed By	Description 1st			
Checked By	Description 2nd	Language	es-ES	
Approved By	1st View	Version	Sheet 9 - 4	

1

2

3

4

A

Nombre	Tipo de datos	Valor predet.	Remanencia	Accesible desde HMI	Visible en HMI	Valor de ajuste	Comentario
Rcv_CFG_SFB[16]	Byte	16#0	No remanente	False	False	False	
Rcv_CFG_SFB[17]	Byte	16#0	No remanente	False	False	False	
Rcv_CFG_SFB[18]	Byte	16#0	No remanente	False	False	False	
Rcv_CFG_SFB[19]	Byte	16#0	No remanente	False	False	False	
Rcv_CFG_SFB[20]	Byte	16#0	No remanente	False	False	False	
Rcv_CFG_SFB[21]	Byte	16#0	No remanente	False	False	False	
Rcv_CFG_SFB[22]	Byte	16#0	No remanente	False	False	False	
Rcv_CFG_SFB[23]	Byte	16#0	No remanente	False	False	False	
Rcv_CFG_SFB[24]	Byte	16#0	No remanente	False	False	False	
Rcv_CFG_SFB[25]	Byte	16#0	No remanente	False	False	False	
Rcv_CFG_SFB[26]	Byte	16#0	No remanente	False	False	False	
Rcv_CFG_SFB[27]	Byte	16#0	No remanente	False	False	False	
Rcv_CFG_SFB[28]	Byte	16#0	No remanente	False	False	False	
Rcv_CFG_SFB[29]	Byte	16#0	No remanente	False	False	False	
Rcv_CFG_SFB[30]	Byte	16#0	No remanente	False	False	False	
Rcv_CFG_SFB[31]	Byte	16#0	No remanente	False	False	False	
Rcv_CFG_SFB[32]	Byte	16#0	No remanente	False	False	False	
Rcv_CFG_SFB[33]	Byte	16#0	No remanente	False	False	False	
Rcv_CFG_SFB[34]	Byte	16#0	No remanente	False	False	False	
Rcv_CFG_SFB[35]	Byte	16#0	No remanente	False	False	False	
Rcv_CFG_SFB[36]	Byte	16#0	No remanente	False	False	False	
Rcv_CFG_SFB[37]	Byte	16#0	No remanente	False	False	False	
Rcv_CFG_SFB[38]	Byte	16#0	No remanente	False	False	False	
Rcv_CFG_SFB[39]	Byte	16#0	No remanente	False	False	False	

B

C

D

E

Owner	Project name	MODBUS_S7-1200_SINAMICS_V20_V13_SP1	Date	12/09/2017
Operator	Project path	C:\Users\integradora\Desktop\TESIS MODBUS\Documentos\S7 1200 - V20 MODBUS RS232\MODBUS_S7-1200_SINAMICS_V20_V13_SP1		
Designed By	Description 1st			
Checked By	Description 2nd	Language	es-ES	
Approved By	1st View	Version	Sheet 9 - 5	

1

2

3

4

A

Nombre	Tipo de datos	Valor predet.	Remanencia	Accesible desde HMI	Visible en HMI	Valor de ajuste	Comentario
Rcv_CFG_SFB[40]	Byte	16#0	No remanente	False	False	False	
Rcv_CFG_SFB[41]	Byte	16#0	No remanente	False	False	False	
Rcv_CFG_SFB[42]	Byte	16#0	No remanente	False	False	False	
Rcv_CFG_SFB[43]	Byte	16#0	No remanente	False	False	False	
Rcv_CFG_SFB[44]	Byte	16#0	No remanente	False	False	False	
Rcv_CFG_SFB[45]	Byte	16#0	No remanente	False	False	False	
Rcv_CFG_SFB[46]	Byte	16#0	No remanente	False	False	False	
Rcv_CFG_SFB[47]	Byte	16#0	No remanente	False	False	False	
Rcv_CFG_SFB[48]	Byte	16#0	No remanente	False	False	False	
Rcv_CFG_SFB[49]	Byte	16#0	No remanente	False	False	False	
Rcv_CFG_SFB[50]	Byte	16#0	No remanente	False	False	False	
Rcv_CFG_SFB[51]	Byte	16#0	No remanente	False	False	False	
Rcv_CFG_SFB[52]	Byte	16#0	No remanente	False	False	False	
Rcv_CFG_SFB[53]	Byte	16#0	No remanente	False	False	False	
Rcv_CFG_SFB[54]	Byte	16#0	No remanente	False	False	False	
Rcv_CFG_SFB[55]	Byte	16#0	No remanente	False	False	False	
Rcv_CFG_SFB[56]	Byte	16#0	No remanente	False	False	False	
Rcv_CFG_SFB[57]	Byte	16#0	No remanente	False	False	False	
Rcv_CFG_SFB[58]	Byte	16#0	No remanente	False	False	False	
Rcv_CFG_SFB[59]	Byte	16#0	No remanente	False	False	False	
Rcv_CFG_SFB[60]	Byte	16#0	No remanente	False	False	False	
STOP_BITS	USInt	1	No remanente	True	True	False	

C

D

E

Owner	Project name	MODBUS_S7-1200_SINAMICS_V20_V13_SP1	Date	12/09/2017
	Operator	Project path C:\Users\integradora\Desktop\TESIS MODBUS\Documentos\S7 1200 - V20 MODBUS RS232\MODBUS_S7-1200_SINAMICS_V20_V13_SP1		
Designed By	Location			
Checked By	Description 1st	Language es-ES		
Approved By	Description 2nd	1st View	Version	Sheet 9 - 6

F

## **ANEXO D**

### **Programación del S7-1200 – ABB ACS355**

# Bloques de programa

## Main [OB1]

### Main Propiedades

#### General

Nombre	Main	Número	1
Tipo	OB	Idioma	KOP
Numeración	automática		

#### Información

Título	"Main Program Sweep (Cycle)"	Autor	
Comentario		Familia	
Versión	0.1	ID personalizada	

Nombre	Tipo de datos	Valor predet.	Comentario
▼ Input			
Initial_Call	Bool		Initial call of this OB
Remanence	Bool		=True, if remanent data are available
Temp			
Constant			

### Segmento 1: STW\_PALABRA\_DE\_MANDO

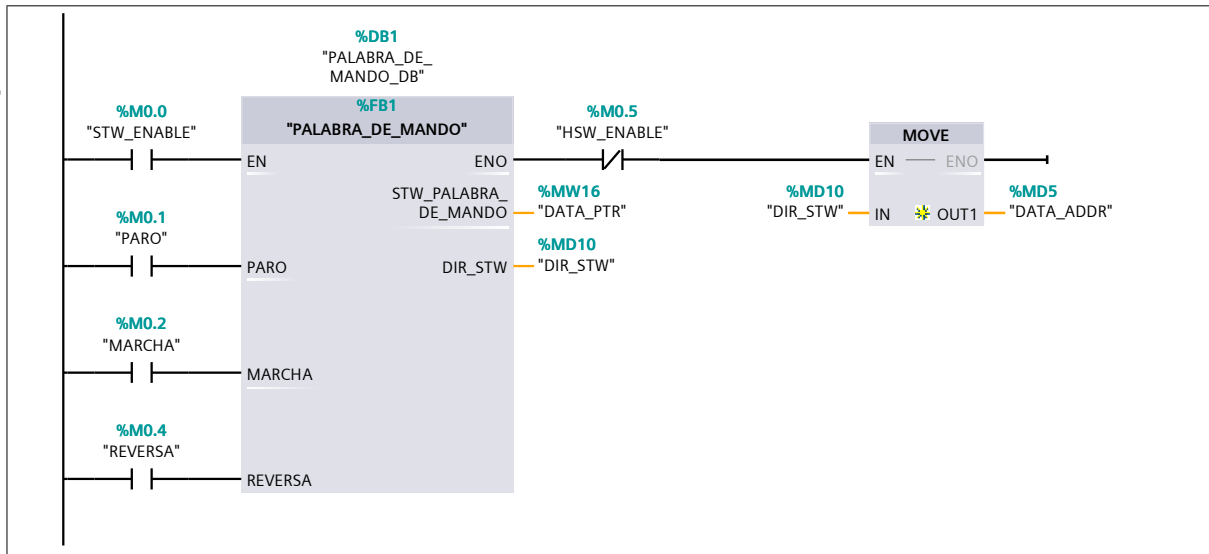

Símbolo	Dirección	Tipo	Comentario
"DATA_ADDR"	%MD5	UDInt	
"DATA_PTR"	%MW16	Word	
"DIR_STW"	%MD10	UDInt	
"HSW_ENABLE"	%M0.5	Bool	
"MARCHA"	%M0.2	Bool	
"PARO"	%M0.1	Bool	

Owner	Project name	MODBUS_S7-1200_ABB_V13_SP1	Date	12/09/2017
Operator	Project path	C:\Users\integradora\Desktop\TESIS MODBUS\Documentos\S7 1200 - V20 MODBUS RS232\MODBUS_S7-1200_ABB_V13_SP1		
Designed By	Description 1st			
Checked By	Description 2nd	Language	es-ES	
Approved By	1st View	Version	Sheet 1 - 1	

Símbolo	Dirección	Tipo	Comentario
"REVERSA"	%MO.4	Bool	
"STW_ENABLE"	%MO.0	Bool	

### Segmento 2: HSW\_CONSIGNA\_DE\_VELOCIDAD

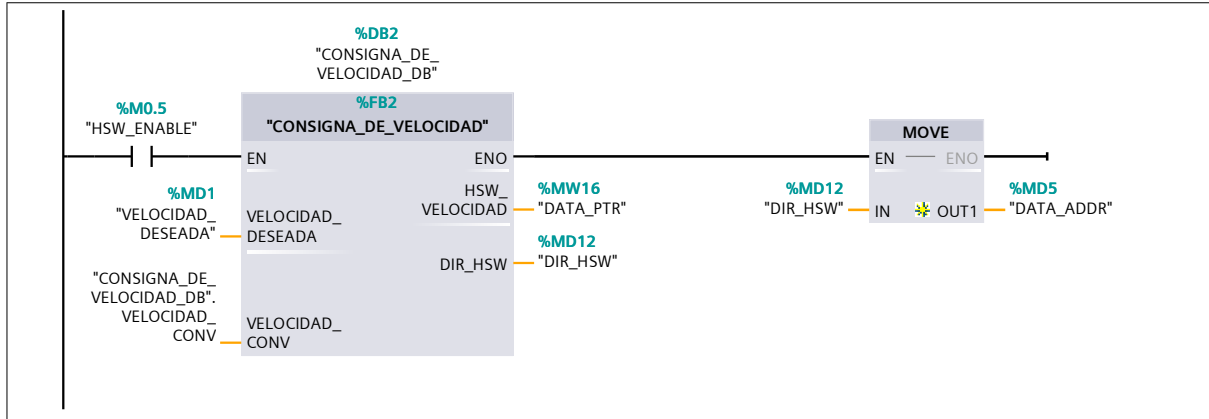

Símbolo	Dirección	Tipo	Comentario
"CONSIGNA_DE_VELOCIDAD_DB".VELOCIDAD_CONV		Real	
"DATA_ADDR"	%MD5	UDInt	
"DATA_PTR"	%MW16	Word	
"DIR_HSW"	%MD12	UDInt	
"HSW_ENABLE"	%M0.5	Bool	
"VELOCIDAD_DESEADA"	%MD1	Real	

### Segmento 3: INICIO\_COMUNICACION\_MODBUS

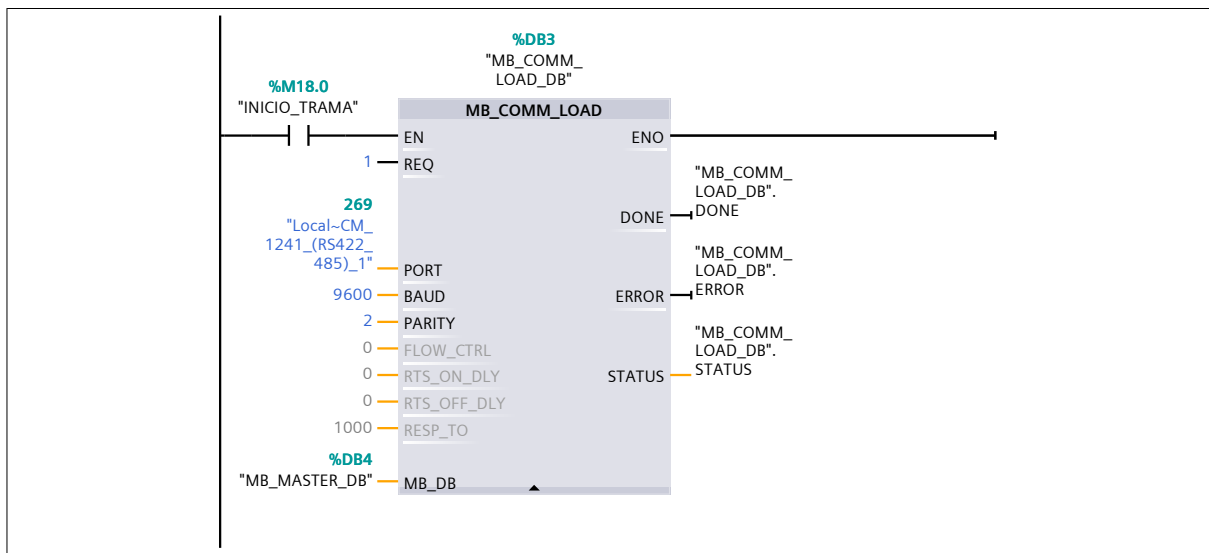

Owner	Project name	MODBUS_S7-1200_ABB_V13_SP1		Date	12/09/2017
Operator	Project path	C:\Users\integradora\Desktop\TESIS MODBUS\Documentos\S7 1200 - V20 MODBUS RS232\MODBUS_S7-1200_ABB_V13_SP1			
Designed By	Description 1st				
Checked By	Description 2nd	Language	es-ES		
Approved By	1st View	Version	Sheet 1 - 2		

Símbolo	Dirección	Tipo	Comentario
"INICIO_TRAMA"	%M18.0	Bool	
"Lo-cal~CM_1241_(RS422_485)_1"	269	PORT	
"MB_COMM_LOAD_D B".DONE		Bool	Boolean indicating completion without error
"MB_COMM_LOAD_D B".ERROR		Bool	Boolean indicating completion with error
"MB_COMM_LOAD_D B".STATUS		Word	Status of the current operation

#### Segmento 4:

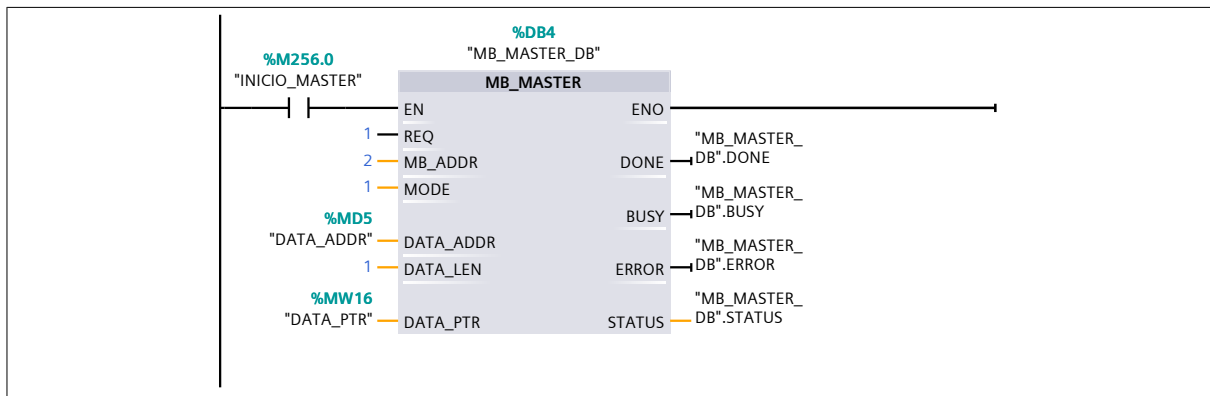

Símbolo	Dirección	Tipo	Comentario
"DATA_ADDR"	%MD5	UDInt	
"DATA_PTR"	%MW16	Word	
"INICIO_MASTER"	%M256.0	Bool	
"MB_MASTER_DB".BUSY		Bool	Boolean indicating operation in progress
"MB_MASTER_DB".DONE		Bool	Boolean indicating completion without error
"MB_MASTER_DB".ERROR		Bool	Boolean indicating completion with error
"MB_MASTER_DB".STATUS		Word	Status or error code of the completed operation

Owner	Project name	MODBUS_S7-1200_ABB_V13_SP1	Date	12/09/2017
	Operator	Project path C:\Users\integradora\Desktop\TESIS MODBUS\Documentos\S7 1200 - V20 MODBUS RS232\MODBUS_S7-1200_ABB_V13_SP1		
Designed By	Location			
Checked By	Description 1st	Language		
Approved By	Description 2nd	es-ES		Sheet 1 - 3
	1st View	Version		



# Bloques de programa

## PALABRA\_DE\_MANDO [FB1]

### PALABRA\_DE\_MANDO Propiedades

#### General

Nombre	PALABRA_DE_MANDO	Número	1
Tipo	FB	Idioma	KOP
Numeración	automática		

#### Información

Título	STW_PALABRA DE MANDO	Autor	
Comentario		Familia	
Versión	0.1	ID personalizada	

Nombre	Tipo de datos	Valor predet.	Remanencia	Accesible desde HMI	Visible en HMI	Valor de ajuste	Comentario
▼ Input							
PARO	Bool	false	No remanente	True	True	False	
MARCHA	Bool	false	No remanente	True	True	False	
REVERSA	Bool	false	No remanente	True	True	False	
▼ Output							
STW_PALABRA_DE_MANDO	Word	16#0	No remanente	True	True	False	
DIR_STW	UDInt	0	No remanente	True	True	False	
InOut							
▼ Static							
LOCAL	Bool	false	No remanente	True	True	False	
REARME	Bool	TRUE	No remanente	True	True	False	
EXT2	Bool	false	No remanente	True	True	False	
RUN_DISABLE	Bool	false	No remanente	True	True	False	
STPMODE_R	Bool	true	No remanente	True	True	False	
STPMODE_EM	Bool	false	No remanente	True	True	False	
STPMODE_C	Bool	false	No remanente	True	True	False	
RAMP_Z	Bool	false	No remanente	True	True	False	
RAMP_HOLD	Bool	false	No remanente	True	True	False	
RAMP_IN_0	Bool	false	No remanente	True	True	False	
REQ_LOCAL_LOC	Bool	true	No remanente	True	True	False	
TOR_LIM_2	Bool	false	No remanente	True	True	False	
STW	Word	16#0	No remanente	True	True	False	
RAMP_OUT_0	Bool	false	No remanente	True	True	False	
Temp							
Constant							

### Segmento 1: DESIGNACION DE PALABRA DE MANDO

Owner	Project name	MODBUS_S7-1200_ABB_V13_SP1	Date	12/09/2017
Operator	Project path	C:\Users\integradora\Desktop\TESIS MODBUS\Documentos\S7 1200 - V20 MODBUS RS232\MODBUS_S7-1200_ABB_V13_SP1		
	Location			
Designed By	Description 1st			
Checked By	Description 2nd	Language	es-ES	
Approved By	1st View	Version	Sheet 2 - 1	

1

2

3

4

A

B

C

D

E

F

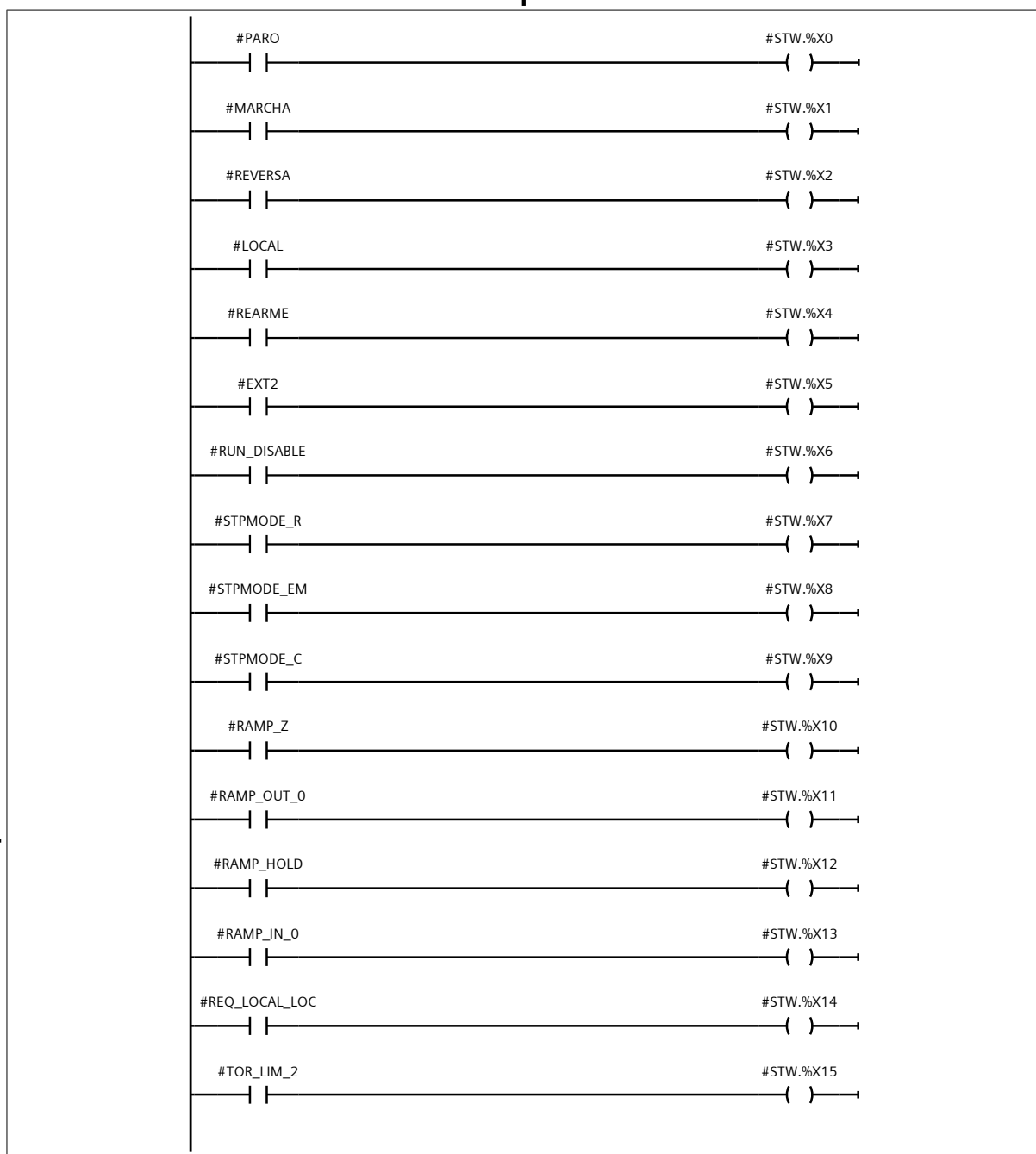

Símbolo	Dirección	Tipo	Comentario
#EXT2		Bool	
#LOCAL		Bool	
#MARCHA		Bool	
#PARO		Bool	
#RAMP_HOLD		Bool	
#RAMP_IN_0		Bool	
#RAMP_OUT_0		Bool	
#RAMP_Z		Bool	
#REARME		Bool	

Owner

Project name MODBUS\_S7-1200\_ABB\_V13\_SP1

Date 12/09/2017

Operator

Project path  
C:\Users\integradora\Desktop\TESIS MODBUS\Documentos\S7 1200 - V20  
MODBUS RS232\MODBUS\_S7-1200\_ABB\_V13\_SP1

Location

Designed By

Description 1st

Checked By

Description 2nd

Language es-ES

Approved By

1st View

Version

Sheet 2 - 2

Símbolo	Dirección	Tipo	Comentario
#REQ_LOCAL_LOC		Bool	
#REVERSA		Bool	
#RUN_DISABLE		Bool	
#STPMODE_C		Bool	
#STPMODE_EM		Bool	
#STPMODE_R		Bool	
#STW.%X0		Bool	
#STW.%X1		Bool	
#STW.%X2		Bool	
#STW.%X3		Bool	
#STW.%X4		Bool	
#STW.%X5		Bool	
#STW.%X6		Bool	
#STW.%X7		Bool	
#STW.%X8		Bool	
#STW.%X9		Bool	
#STW.%X10		Bool	
#STW.%X11		Bool	
#STW.%X12		Bool	
#STW.%X13		Bool	
#STW.%X14		Bool	
#STW.%X15		Bool	
#TOR_LIM_2		Bool	

### Segmento 2: ENVIO DE PALABRA DE MANDO

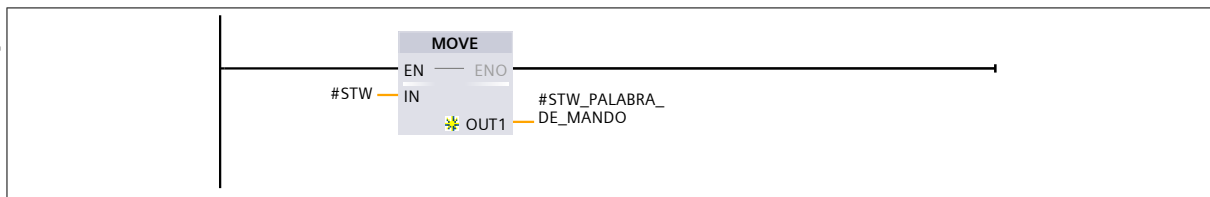

Símbolo	Dirección	Tipo	Comentario
#STW		Word	
#STW_PALABRA_DE_MANDO		Word	

### Segmento 3: DIRECCIONAMIENTO

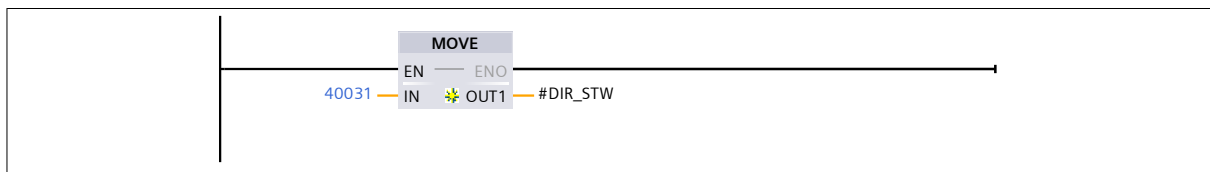

Símbolo	Dirección	Tipo	Comentario
#DIR_STW		UDInt	

Owner	Project name	MODBUS_S7-1200_ABB_V13_SP1	Date	12/09/2017
	Operator	Project path C:\Users\integradora\Desktop\TESIS MODBUS\Documentos\S7 1200 - V20 MODBUS RS232\MODBUS_S7-1200_ABB_V13_SP1		
Designed By	Location			
Checked By	Description 1st		Language	
Approved By	Description 2nd		es-ES	
	1st View		Version	Sheet 2 - 3

# Bloques de programa

## PALABRA\_DE\_MANDO\_DB [DB1]

### PALABRA\_DE\_MANDO\_DB Propiedades

#### General

Nombre	PALABRA_DE_MANDO_DB	Número	1
Tipo	DB	Idioma	DB
Numeración	automática		

#### Información

Título		Autor	
Comentario		Familia	
Versión	0.1	ID personalizada	

Nombre	Tipo de datos	Valor de arranque	Remanencia	Accesible desde HMI	Visible en HMI	Valor de ajuste	Comentario
▼ Input							
PARO	Bool	false	False	True	True	False	
MARCHA	Bool	false	False	True	True	False	
REVERSA	Bool	false	False	True	True	False	
▼ Output							
STW_PALABRA_DE_MANDO	Word	16#0	False	True	True	False	
DIR_STW	UDInt	0	False	True	True	False	
InOut							
▼ Static							
LOCAL	Bool	false	False	True	True	False	
REARME	Bool	TRUE	False	True	True	False	
EXT2	Bool	false	False	True	True	False	
RUN_DISABLE	Bool	false	False	True	True	False	
STPMODE_R	Bool	true	False	True	True	False	
STPMODE_EM	Bool	false	False	True	True	False	
STPMODE_C	Bool	false	False	True	True	False	
RAMP_Z	Bool	false	False	True	True	False	
RAMP_HOLD	Bool	false	False	True	True	False	
RAMP_IN_0	Bool	false	False	True	True	False	
REQ_LOCAL_LOC	Bool	true	False	True	True	False	
TOR_LIM_2	Bool	false	False	True	True	False	
STW	Word	16#0	False	True	True	False	
RAMP_OUT_0	Bool	false	False	True	True	False	

Owner	Project name	MODBUS_S7-1200_ABB_V13_SP1	Date	12/09/2017
	Operator	Project path C:\Users\integradora\Desktop\TESIS MODBUS\Documentos\S7 1200 - V20 MODBUS RS232\MODBUS_S7-1200_ABB_V13_SP1		
Designed By	Location			
Checked By	Description 1st	Language es-ES		
Approved By	Description 2nd	1st View	Version	Sheet 3 - 1

# Bloques de programa

## CONSIGNA\_DE\_VELOCIDAD [FB2]

### CONSIGNA\_DE\_VELOCIDAD Propiedades

General			
Nombre	CONSIGNA_DE_VELOCIDAD	Número	2
Tipo	FB	Idioma	KOP
Numeración	automática		
Información			
Título	HSW_CONSIGNA_DE_VELOCIDAD	Autor	
Comentario		Familia	
Versión	0.1	ID personalizada	

Nombre	Tipo de datos	Valor predet.	Remanencia	Accesible desde HMI	Visible en HMI	Valor de ajuste	Comentario
▼ Input							
VELOCIDAD_DESEADA	Real	0.0	No remanente	True	True	False	
▼ Output							
HSW_VELOCIDAD	Word	16#0	No remanente	True	True	False	
DIR_HSW	UDInt	0	No remanente	True	True	False	
▼ InOut							
VELOCIDAD_CONV	Real	0.0	No remanente	True	True	False	
Static							
Temp							
Constant							

### Segmento 1: INGRESO DE VELOCIDAD DESEADA EN HZ

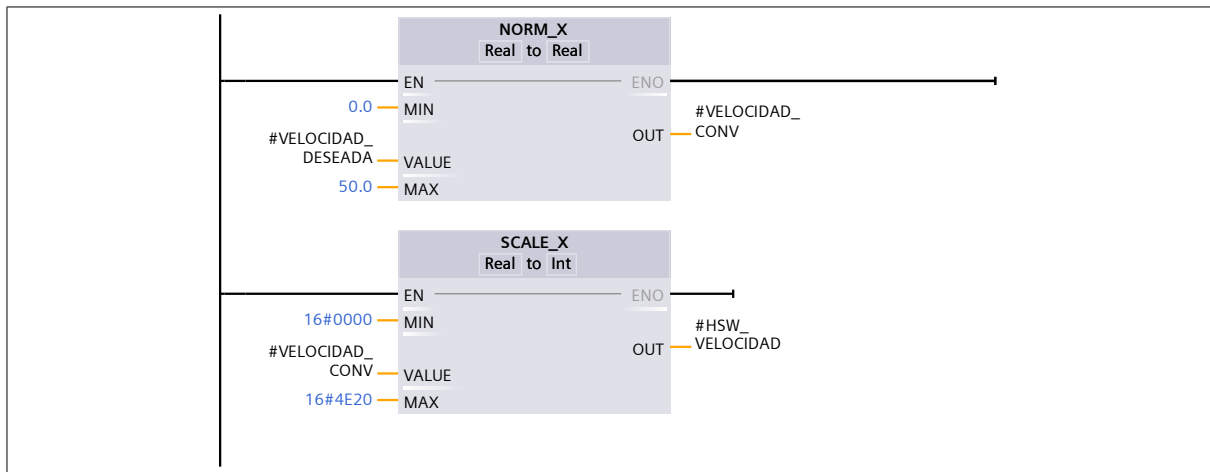

Owner	Project name	MODBUS_S7-1200_ABB_V13_SP1		Date	12/09/2017
Operator	Project path	C:\Users\integradora\Desktop\TESIS MODBUS\Documentos\S7 1200 - V20 MODBUS RS232\MODBUS_S7-1200_ABB_V13_SP1			
Designed By	Description 1st				
Checked By	Description 2nd	Language	es-ES		
Approved By	1st View	Version	Sheet 4 - 1		

Símbolo	Dirección	Tipo	Comentario
#HSW_VELOCIDAD		Word	
#VELOCIDAD_CONV		Real	
#VELOCIDAD_DESEADA		Real	

### Segmento 2: DIRECCIONAMIENTO

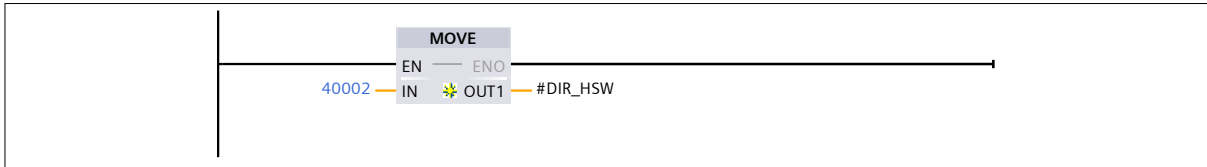

Símbolo	Dirección	Tipo	Comentario
#DIR_HSW		UDInt	

Owner	Project name	MODBUS_S7-1200_ABB_V13_SP1	Date	12/09/2017
	Operator	Project path C:\Users\integradora\Desktop\TESIS MODBUS\Documentos\S7 1200 - V20 MODBUS RS232\MODBUS_S7-1200_ABB_V13_SP1		
Designed By	Location			
Checked By	Description 1st	Language es-ES		
Approved By	Description 2nd	1st View	Version	Sheet 4 - 2

# Bloques de programa

## CONSIGNA\_DE\_VELOCIDAD\_DB [DB2]

### CONSIGNA\_DE\_VELOCIDAD\_DB Propiedades

#### General

Nombre	CONSIGNA_DE_VELOCIDAD_DB	Número	2
Tipo	DB	Idioma	DB
Numeración	automática		

#### Información

Título		Autor	
Comentario		Familia	
Versión	0.1	ID personalizada	

Nombre	Tipo de datos	Valor de arranque	Remanencia	Accesible desde HMI	Visible en HMI	Valor de ajuste	Comentario
▼ Input							
VELOCIDAD_DE-SEADA	Real	0.0	False	True	True	False	
▼ Output							
HSW_VELOCIDAD	Word	16#0	False	True	True	False	
DIR_HSW	UDInt	0	False	True	True	False	
▼ InOut							
VELOCIDAD_CONV	Real	0.0	False	True	True	False	
Static							

Owner	Project name	MODBUS_S7-1200_ABB_V13_SP1	Date	12/09/2017
Operator	Project path	C:\Users\integradora\Desktop\TESIS MODBUS\Documentos\S7 1200 - V20 MODBUS RS232\MODBUS_S7-1200_ABB_V13_SP1		
Designed By	Description 1st			
Checked By	Description 2nd	Language	es-ES	
Approved By	1st View	Version	Sheet 5 - 1	

# Bloques de programa / Bloques de sistema / Recursos de programa

## MB\_COMM\_LOAD\_DB [DB3]

### MB\_COMM\_LOAD\_DB Propiedades

#### General

Nombre	MB_COMM_LOAD_DB	Número	3
Tipo	DB	Idioma	DB
Numeración	automática		

#### Información

Título		Autor	SIMATIC
Comentario		Familia	MODBUS
Versión	2.1	ID personalizada	MB_CM_LD

Nombre	Tipo de datos	Valor de arranque	Remanencia	Accesible desde HMI	Visible en HMI	Valor de ajuste	Comentario
▼ Input							
REQ	Bool	FALSE	False	True	True	False	The enable to initiate a Modbus configuration operation
PORT	PORT	16#FFFF	False	True	True	False	The PtP hardware address
BAUD	UDInt	0	False	True	True	False	The baud rate of the PtP port
PARITY	UInt	0	False	True	True	False	The parity of the PtP port
FLOW_CTRL	UInt	0	False	True	True	False	Transmit and receive flow control
RTS_ON_DLY	UInt	0	False	True	True	False	The enable time of RTS before sending the first character
RTS_OFF_DLY	UInt	0	False	True	True	False	The enable time of RTS after sending the last character
RESP_TO	UInt	1000	False	True	True	False	The time to wait for the Modbus slave to respond
▼ Output							
DONE	Bool	FALSE	False	True	True	False	Boolean indicating completion without error
ERROR	Bool	FALSE	False	True	True	False	Boolean indicating completion with error
STATUS	Word	W#16#0	False	True	True	False	Status of the current operation
▼ InOut							
MB_DB	MB_BASE		False	False	False	False	The instance DB of the Modbus master or slave
▼ Static							
ICHAR_GAP	UInt	0	False	True	True	False	

Owner	Project name	MODBUS_S7-1200_ABB_V13_SP1	Date	12/09/2017
Operator	Project path	C:\Users\integradora\Desktop\TESIS MODBUS\Documentos\S7 1200 - V20 MODBUS RS232\MODBUS_S7-1200_ABB_V13_SP1		
Designed By	Description 1st			
Checked By	Description 2nd	Language	es-ES	
Approved By	1st View	Version	Sheet 6 - 1	



Nombre	Tipo de datos	Valor de arranque	Remanencia	Accesible desde HMI	Visible en HMI	Valor de ajuste	Comentario
RETRIES	UInt	2	False	True	True	False	
WRREC_STATUS	Word	2	False	True	True	False	
RDREC_STATUS	Word	2	False	True	True	False	
SFC_STATUS	Word	2	False	True	True	False	
▼ Port_CFG_SFB	Array[0..25] of Byte		False	False	False	False	
Port_CFG_SFB[0]	Byte	16#0	False	False	False	False	
Port_CFG_SFB[1]	Byte	16#0	False	False	False	False	
Port_CFG_SFB[2]	Byte	16#0	False	False	False	False	
Port_CFG_SFB[3]	Byte	16#0	False	False	False	False	
Port_CFG_SFB[4]	Byte	16#0	False	False	False	False	
Port_CFG_SFB[5]	Byte	16#0	False	False	False	False	
Port_CFG_SFB[6]	Byte	16#0	False	False	False	False	
Port_CFG_SFB[7]	Byte	16#0	False	False	False	False	
Port_CFG_SFB[8]	Byte	16#0	False	False	False	False	
Port_CFG_SFB[9]	Byte	16#0	False	False	False	False	
Port_CFG_SFB[10]	Byte	16#0	False	False	False	False	
Port_CFG_SFB[11]	Byte	16#0	False	False	False	False	
Port_CFG_SFB[12]	Byte	16#0	False	False	False	False	
Port_CFG_SFB[13]	Byte	16#0	False	False	False	False	
Port_CFG_SFB[14]	Byte	16#0	False	False	False	False	
Port_CFG_SFB[15]	Byte	16#0	False	False	False	False	
Port_CFG_SFB[16]	Byte	16#0	False	False	False	False	
Port_CFG_SFB[17]	Byte	16#0	False	False	False	False	
Port_CFG_SFB[18]	Byte	16#0	False	False	False	False	
Port_CFG_SFB[19]	Byte	16#0	False	False	False	False	

Owner	Project name	MODBUS_S7-1200_ABB_V13_SP1	Date	12/09/2017
	Operator	Project path C:\Users\integradora\Desktop\TESIS MODBUS\Documentos\S7 1200 - V20 MODBUS RS232\MODBUS_S7-1200_ABB_V13_SP1		
Designed By	Location			
Checked By	Description 1st	Language es-ES		
Approved By	Description 2nd	1st View	Version	Sheet 6 - 2

A

B

C

D

E

F

Nombre	Tipo de datos	Valor de arranque	Remanencia	Accesible desde HMI	Visible en HMI	Valor de ajuste	Comentario
Port_CFG_SFB[20]	Byte	16#0	False	False	False	False	
Port_CFG_SFB[21]	Byte	16#0	False	False	False	False	
Port_CFG_SFB[22]	Byte	16#0	False	False	False	False	
Port_CFG_SFB[23]	Byte	16#0	False	False	False	False	
Port_CFG_SFB[24]	Byte	16#0	False	False	False	False	
Port_CFG_SFB[25]	Byte	16#0	False	False	False	False	
▼ Send_CFG_SFB	Array[0..16] of Byte		False	False	False	False	
Send_CFG_SFB[0]	Byte	16#0	False	False	False	False	
Send_CFG_SFB[1]	Byte	16#0	False	False	False	False	
Send_CFG_SFB[2]	Byte	16#0	False	False	False	False	
Send_CFG_SFB[3]	Byte	16#0	False	False	False	False	
Send_CFG_SFB[4]	Byte	16#0	False	False	False	False	
Send_CFG_SFB[5]	Byte	16#0	False	False	False	False	
Send_CFG_SFB[6]	Byte	16#0	False	False	False	False	
Send_CFG_SFB[7]	Byte	16#0	False	False	False	False	
Send_CFG_SFB[8]	Byte	16#0	False	False	False	False	
Send_CFG_SFB[9]	Byte	16#0	False	False	False	False	
Send_CFG_SFB[10]	Byte	16#0	False	False	False	False	
Send_CFG_SFB[11]	Byte	16#0	False	False	False	False	
Send_CFG_SFB[12]	Byte	16#0	False	False	False	False	
Send_CFG_SFB[13]	Byte	16#0	False	False	False	False	
Send_CFG_SFB[14]	Byte	16#0	False	False	False	False	
Send_CFG_SFB[15]	Byte	16#0	False	False	False	False	
Send_CFG_SFB[16]	Byte	16#0	False	False	False	False	

Owner	Project name MODBUS_S7-1200_ABB_V13_SP1		Date 12/09/2017
	Project path C:\Users\integradora\Desktop\TESIS MODBUS\Documentos\S7 1200 - V20 MODBUS RS232\MODBUS_S7-1200_ABB_V13_SP1		
Operator	Location		
Designed By	Description 1st		
Checked By	Description 2nd	Language es-ES	
Approved By	1st View	Version	Sheet 6 - 3

1

2

3

4

A

Nombre	Tipo de datos	Valor de arranque	Remanencia	Accesible desde HMI	Visible en HMI	Valor de ajuste	Comentario
▼ Rcv_CFG_SFB	Array[0..60] of Byte		False	False	False	False	
Rcv_CFG_SFB[0]	Byte	16#0	False	False	False	False	
Rcv_CFG_SFB[1]	Byte	16#0	False	False	False	False	
Rcv_CFG_SFB[2]	Byte	16#0	False	False	False	False	
Rcv_CFG_SFB[3]	Byte	16#0	False	False	False	False	
Rcv_CFG_SFB[4]	Byte	16#0	False	False	False	False	
Rcv_CFG_SFB[5]	Byte	16#0	False	False	False	False	
Rcv_CFG_SFB[6]	Byte	16#0	False	False	False	False	
Rcv_CFG_SFB[7]	Byte	16#0	False	False	False	False	
Rcv_CFG_SFB[8]	Byte	16#0	False	False	False	False	
Rcv_CFG_SFB[9]	Byte	16#0	False	False	False	False	
Rcv_CFG_SFB[10]	Byte	16#0	False	False	False	False	
Rcv_CFG_SFB[11]	Byte	16#0	False	False	False	False	
Rcv_CFG_SFB[12]	Byte	16#0	False	False	False	False	
Rcv_CFG_SFB[13]	Byte	16#0	False	False	False	False	
Rcv_CFG_SFB[14]	Byte	16#0	False	False	False	False	
Rcv_CFG_SFB[15]	Byte	16#0	False	False	False	False	
Rcv_CFG_SFB[16]	Byte	16#0	False	False	False	False	
Rcv_CFG_SFB[17]	Byte	16#0	False	False	False	False	
Rcv_CFG_SFB[18]	Byte	16#0	False	False	False	False	
Rcv_CFG_SFB[19]	Byte	16#0	False	False	False	False	
Rcv_CFG_SFB[20]	Byte	16#0	False	False	False	False	
Rcv_CFG_SFB[21]	Byte	16#0	False	False	False	False	
Rcv_CFG_SFB[22]	Byte	16#0	False	False	False	False	
Rcv_CFG_SFB[23]	Byte	16#0	False	False	False	False	
Rcv_CFG_SFB[24]	Byte	16#0	False	False	False	False	
Rcv_CFG_SFB[25]	Byte	16#0	False	False	False	False	
Rcv_CFG_SFB[26]	Byte	16#0	False	False	False	False	
Rcv_CFG_SFB[27]	Byte	16#0	False	False	False	False	
Rcv_CFG_SFB[28]	Byte	16#0	False	False	False	False	
Rcv_CFG_SFB[29]	Byte	16#0	False	False	False	False	
Rcv_CFG_SFB[30]	Byte	16#0	False	False	False	False	
Rcv_CFG_SFB[31]	Byte	16#0	False	False	False	False	
Rcv_CFG_SFB[32]	Byte	16#0	False	False	False	False	
Rcv_CFG_SFB[33]	Byte	16#0	False	False	False	False	
Rcv_CFG_SFB[34]	Byte	16#0	False	False	False	False	
Rcv_CFG_SFB[35]	Byte	16#0	False	False	False	False	
Rcv_CFG_SFB[36]	Byte	16#0	False	False	False	False	
Rcv_CFG_SFB[37]	Byte	16#0	False	False	False	False	
Rcv_CFG_SFB[38]	Byte	16#0	False	False	False	False	
Rcv_CFG_SFB[39]	Byte	16#0	False	False	False	False	
Rcv_CFG_SFB[40]	Byte	16#0	False	False	False	False	
Rcv_CFG_SFB[41]	Byte	16#0	False	False	False	False	
Rcv_CFG_SFB[42]	Byte	16#0	False	False	False	False	
Rcv_CFG_SFB[43]	Byte	16#0	False	False	False	False	
Rcv_CFG_SFB[44]	Byte	16#0	False	False	False	False	
Rcv_CFG_SFB[45]	Byte	16#0	False	False	False	False	
Rcv_CFG_SFB[46]	Byte	16#0	False	False	False	False	
Rcv_CFG_SFB[47]	Byte	16#0	False	False	False	False	
Rcv_CFG_SFB[48]	Byte	16#0	False	False	False	False	
Rcv_CFG_SFB[49]	Byte	16#0	False	False	False	False	
Rcv_CFG_SFB[50]	Byte	16#0	False	False	False	False	
Rcv_CFG_SFB[51]	Byte	16#0	False	False	False	False	
Rcv_CFG_SFB[52]	Byte	16#0	False	False	False	False	
Rcv_CFG_SFB[53]	Byte	16#0	False	False	False	False	
Rcv_CFG_SFB[54]	Byte	16#0	False	False	False	False	
Rcv_CFG_SFB[55]	Byte	16#0	False	False	False	False	
Rcv_CFG_SFB[56]	Byte	16#0	False	False	False	False	
Rcv_CFG_SFB[57]	Byte	16#0	False	False	False	False	
Rcv_CFG_SFB[58]	Byte	16#0	False	False	False	False	
Rcv_CFG_SFB[59]	Byte	16#0	False	False	False	False	

C

D

E

F

Owner	Project name	MODBUS_S7-1200_ABB_V13_SP1	Date	12/09/2017
Operator	Project path	C:\Users\integradora\Desktop\TESIS MODBUS\Documentos\S7 1200 - V20 MODBUS RS232\MODBUS_S7-1200_ABB_V13_SP1		
Designed By	Description 1st			
Checked By	Description 2nd	Language	es-ES	
Approved By	1st View	Version	Sheet 6 - 4	

1

2

3

4

A

Nombre	Tipo de datos	Valor de arranque	Remanencia	Accesible desde HMI	Visible en HMI	Valor de ajuste	Comentario
Rcv_CFG_SFB[2 3]	Byte	16#0	False	False	False	False	
Rcv_CFG_SFB[2 4]	Byte	16#0	False	False	False	False	
Rcv_CFG_SFB[2 5]	Byte	16#0	False	False	False	False	
Rcv_CFG_SFB[2 6]	Byte	16#0	False	False	False	False	
Rcv_CFG_SFB[2 7]	Byte	16#0	False	False	False	False	
Rcv_CFG_SFB[2 8]	Byte	16#0	False	False	False	False	
Rcv_CFG_SFB[2 9]	Byte	16#0	False	False	False	False	
Rcv_CFG_SFB[3 0]	Byte	16#0	False	False	False	False	
Rcv_CFG_SFB[3 1]	Byte	16#0	False	False	False	False	
Rcv_CFG_SFB[3 2]	Byte	16#0	False	False	False	False	
Rcv_CFG_SFB[3 3]	Byte	16#0	False	False	False	False	
Rcv_CFG_SFB[3 4]	Byte	16#0	False	False	False	False	
Rcv_CFG_SFB[3 5]	Byte	16#0	False	False	False	False	
Rcv_CFG_SFB[3 6]	Byte	16#0	False	False	False	False	
Rcv_CFG_SFB[3 7]	Byte	16#0	False	False	False	False	
Rcv_CFG_SFB[3 8]	Byte	16#0	False	False	False	False	
Rcv_CFG_SFB[3 9]	Byte	16#0	False	False	False	False	
Rcv_CFG_SFB[4 0]	Byte	16#0	False	False	False	False	
Rcv_CFG_SFB[4 1]	Byte	16#0	False	False	False	False	
Rcv_CFG_SFB[4 2]	Byte	16#0	False	False	False	False	
Rcv_CFG_SFB[4 3]	Byte	16#0	False	False	False	False	
Rcv_CFG_SFB[4 4]	Byte	16#0	False	False	False	False	
Rcv_CFG_SFB[4 5]	Byte	16#0	False	False	False	False	
Rcv_CFG_SFB[4 6]	Byte	16#0	False	False	False	False	

C

D

E

F

Owner	Project name	MODBUS_S7-1200_ABB_V13_SP1	Date	12/09/2017
Operator	Project path	C:\Users\integradora\Desktop\TESIS MODBUS\Documentos\S7 1200 - V20 MODBUS RS232\MODBUS_S7-1200_ABB_V13_SP1		
Designed By	Description 1st			
Checked By	Description 2nd	Language	es-ES	
Approved By	1st View	Version	Sheet 6 - 5	

1

2

3

4

A

Nombre	Tipo de datos	Valor de arranque	Remanencia	Accesible desde HMI	Visible en HMI	Valor de ajuste	Comentario
Rcv_CFG_SFB[4 7]	Byte	16#0	False	False	False	False	
Rcv_CFG_SFB[4 8]	Byte	16#0	False	False	False	False	
Rcv_CFG_SFB[4 9]	Byte	16#0	False	False	False	False	
Rcv_CFG_SFB[5 0]	Byte	16#0	False	False	False	False	
Rcv_CFG_SFB[5 1]	Byte	16#0	False	False	False	False	
Rcv_CFG_SFB[5 2]	Byte	16#0	False	False	False	False	
Rcv_CFG_SFB[5 3]	Byte	16#0	False	False	False	False	
Rcv_CFG_SFB[5 4]	Byte	16#0	False	False	False	False	
Rcv_CFG_SFB[5 5]	Byte	16#0	False	False	False	False	
Rcv_CFG_SFB[5 6]	Byte	16#0	False	False	False	False	
Rcv_CFG_SFB[5 7]	Byte	16#0	False	False	False	False	
Rcv_CFG_SFB[5 8]	Byte	16#0	False	False	False	False	
Rcv_CFG_SFB[5 9]	Byte	16#0	False	False	False	False	
Rcv_CFG_SFB[6 0]	Byte	16#0	False	False	False	False	
STOP_BITS	USInt	1	False	True	True	False	

B

C

D

E

F

Owner	Project name	MODBUS_S7-1200_ABB_V13_SP1	Date	12/09/2017
Operator	Project path	C:\Users\integradora\Desktop\TESIS MODBUS\Documentos\S7 1200 - V20 MODBUS RS232\MODBUS_S7-1200_ABB_V13_SP1		
	Location			
Designed By	Description 1st			
Checked By	Description 2nd	Language	es-ES	
Approved By	1st View	Version	Sheet 6 - 6	

# Bloques de programa / Bloques de sistema / Recursos de programa

## MB\_MASTER\_DB [DB4]

### MB\_MASTER\_DB Propiedades

#### General

Nombre	MB_MASTER_DB	Número	4
Tipo	DB	Idioma	DB
Numeración	automática		

#### Información

Título		Autor	SIMATIC
Comentario		Familia	MODBUS
Versión	2.2	ID personalizada	MB_MASTR

Nombre	Tipo de datos	Valor de arranque	Remanencia	Accesible desde HMI	Visible en HMI	Valor de ajuste	Comentario
▼ Base	MB_BASE		False	True	True	False	
Input							
Output							
InOut							
▼ Static							
S_PORT	UInt	16#FFFF	False	False	False	False	
S_RESP_TO	UInt	1000	False	False	False	False	
S_ICHAR_GAP	UInt	28	False	False	False	False	
S_RETRIES	UInt	2	False	False	False	False	
▼ Input							
REQ	Bool	FALSE	False	True	True	False	The enable to initiate a Modbus master request
MB_ADDR	UInt	0	False	True	True	False	The station address of the Modbus slave
MODE	USInt	0	False	True	True	False	Specifies a read, write, or diagnostic operation
DATA_ADDR	UDInt	0	False	True	True	False	The Modbus data address
DATA_LEN	UInt	0	False	True	True	False	The Modbus data length
▼ Output							
DONE	Bool	FALSE	False	True	True	False	Boolean indicating completion without error
BUSY	Bool	FALSE	False	True	True	False	Boolean indicating operation in progress
ERROR	Bool	FALSE	False	True	True	False	Boolean indicating completion with error
STATUS	Word	W#16#0	False	True	True	False	Status or error code of the completed operation
▼ InOut							

Owner	Project name	MODBUS_S7-1200_ABB_V13_SP1	Date	12/09/2017
Operator	Project path	C:\Users\integradora\Desktop\TESIS MODBUS\Documentos\S7 1200 - V20 MODBUS RS232\MODBUS_S7-1200_ABB_V13_SP1		
Designed By	Description 1st			
Checked By	Description 2nd	Language	es-ES	
Approved By	1st View	Version	Sheet 7 - 1	

A

Nombre	Tipo de datos	Valor de arranque	Remanencia	Accesible desde HMI	Visible en HMI	Valor de ajuste	Comentario
DATA_PTR	Variant		False	False	False	False	Data area used to communicate with the Modbus slave
▼ Static							
▼ SEND_PTP_SFB	Array[0..11] of Byte		False	False	False	False	
SEND_PTP_SFB[0]	Byte	16#0	False	False	False	False	
SEND_PTP_SFB[1]	Byte	16#0	False	False	False	False	
SEND_PTP_SFB[2]	Byte	16#0	False	False	False	False	
SEND_PTP_SFB[3]	Byte	16#0	False	False	False	False	
SEND_PTP_SFB[4]	Byte	16#0	False	False	False	False	
SEND_PTP_SFB[5]	Byte	16#0	False	False	False	False	
SEND_PTP_SFB[6]	Byte	16#0	False	False	False	False	
SEND_PTP_SFB[7]	Byte	16#0	False	False	False	False	
SEND_PTP_SFB[8]	Byte	16#0	False	False	False	False	
SEND_PTP_SFB[9]	Byte	16#0	False	False	False	False	
SEND_PTP_SFB[10]	Byte	16#0	False	False	False	False	
SEND_PTP_SFB[11]	Byte	16#0	False	False	False	False	
▼ RCV_PTP_SFB	Array[0..11] of Byte		False	False	False	False	
RCV_PTP_SFB[0]	Byte	16#0	False	False	False	False	
RCV_PTP_SFB[1]	Byte	16#0	False	False	False	False	
RCV_PTP_SFB[2]	Byte	16#0	False	False	False	False	
RCV_PTP_SFB[3]	Byte	16#0	False	False	False	False	
RCV_PTP_SFB[4]	Byte	16#0	False	False	False	False	
RCV_PTP_SFB[5]	Byte	16#0	False	False	False	False	
RCV_PTP_SFB[6]	Byte	16#0	False	False	False	False	

B

C

D

E

F

Owner	Project name	MODBUS_S7-1200_ABB_V13_SP1	Date	12/09/2017
Operator	Project path	C:\Users\integradora\Desktop\TESIS MODBUS\Documentos\S7 1200 - V20 MODBUS RS232\MODBUS_S7-1200_ABB_V13_SP1		
Designed By	Description 1st			
Checked By	Description 2nd	Language	es-ES	
Approved By	1st View	Version	Sheet 7 - 2	

A

B

C

D

E

F

Nombre	Tipo de datos	Valor de arranque	Remanencia	Accesible desde HMI	Visible en HMI	Valor de ajuste	Comentario
RCV_PTP_SFB[7]	Byte	16#0	False	False	False	False	
RCV_PTP_SFB[8]	Byte	16#0	False	False	False	False	
RCV_PTP_SFB[9]	Byte	16#0	False	False	False	False	
RCV_PTP_SFB[10]	Byte	16#0	False	False	False	False	
RCV_PTP_SFB[11]	Byte	16#0	False	False	False	False	
▼ RCV_RST_SFB	Array[0..9] of Byte		False	False	False	False	
RCV_RST_SFB[0]	Byte	16#0	False	False	False	False	
RCV_RST_SFB[1]	Byte	16#0	False	False	False	False	
RCV_RST_SFB[2]	Byte	16#0	False	False	False	False	
RCV_RST_SFB[3]	Byte	16#0	False	False	False	False	
RCV_RST_SFB[4]	Byte	16#0	False	False	False	False	
RCV_RST_SFB[5]	Byte	16#0	False	False	False	False	
RCV_RST_SFB[6]	Byte	16#0	False	False	False	False	
RCV_RST_SFB[7]	Byte	16#0	False	False	False	False	
RCV_RST_SFB[8]	Byte	16#0	False	False	False	False	
RCV_RST_SFB[9]	Byte	16#0	False	False	False	False	
PF_FREQUENCY	Real	0.0	False	False	False	False	
BLOCKED_PROC_TIMEOUT	Real	3.0	False	True	True	False	
CURRENT_TIME_VALUE	UDInt	0	False	False	False	False	
SAVED_TIME_VALUE	UDInt	0	False	False	False	False	
SAVED_SLAVE_ADDR	Word	0	False	False	False	False	
SAVED_MODE	Word	0	False	False	False	False	
SAVED_DATA_ADDR	DWord	0	False	False	False	False	
SAVED_DATA_LEN	UInt	0	False	False	False	False	
MB_STATE	UInt	0	False	False	False	False	

Owner	Project name	MODBUS_S7-1200_ABB_V13_SP1	Date	12/09/2017
Operator	Project path	C:\Users\integradora\Desktop\TESIS MODBUS\Documentos\S7 1200 - V20 MODBUS RS232\MODBUS_S7-1200_ABB_V13_SP1		
Designed By	Description 1st			
Checked By	Description 2nd	Language	es-ES	
Approved By	1st View	Version	Sheet 7 - 3	



1

2

3

4

A

Nombre	Tipo de datos	Valor de arranque	Remanencia	Accesible desde HMI	Visible en HMI	Valor de ajuste	Comentario
COMM_SENT_CO UNT	UInt	0	False	False	False	False	
BYTE_COUNT	USInt	0	False	False	False	False	
INIT_OK	Bool	FALSE	False	False	False	False	
ACTIVE	Bool	FALSE	False	False	False	False	
BROADCAST_FLAG	Bool	FALSE	False	False	False	False	
EXTENDED_AD- DRESSING	Bool	FALSE	False	True	True	False	
SAVED_START_AD DR	UInt	0	False	False	False	False	
TXBuf_Func- tion_Offset	UDInt	0	False	False	False	False	
TXBuf_Ad- dress_Offset	UDInt	0	False	False	False	False	
TXBuf_Quanti- ty_Offset	UDInt	0	False	False	False	False	

B

C

D

E

F

Owner	Project name	MODBUS_S7-1200_ABB_V13_SP1	Date	12/09/2017
Operator	Project path	C:\Users\integradora\Desktop\TESIS MODBUS\Documentos\S7 1200 - V20 MODBUS RS232\MODBUS_S7-1200_ABB_V13_SP1		
	Location			
Designed By	Description 1st			
Checked By	Description 2nd	Language	es-ES	
Approved By	1st View	Version	Sheet 7 - 4	

# Bloques de programa / Bloques de sistema / Recursos de programa

## MB\_MASTER [FB1081]

### MB\_MASTER Propiedades

#### General

Nombre	MB_MASTER	Número	1081
Tipo	FB	Idioma	KOP
Numeración	automática		

#### Información

Título		Autor	SIMATIC
Comentario		Familia	MODBUS
Versión	2.2	ID personalizada	MB_MASTR

Nombre	Tipo de datos	Valor predet.	Remanencia	Accesible desde HMI	Visible en HMI	Valor de ajuste	Comentario
▼ Base	MB_BASE			True	True	False	
Input							
Output							
InOut							
▼ Static							
S_PORT	UInt	16#FFFF	No remanente	False	False	False	
S_RESP_TO	UInt	1000	No remanente	False	False	False	
S_ICHAR_GAP	UInt	28	No remanente	False	False	False	
S_RETRIES	UInt	2	No remanente	False	False	False	
▼ Input							
REQ	Bool	FALSE	No remanente	True	True	False	The enable to initiate a Modbus master request
MB_ADDR	UInt	0	No remanente	True	True	False	The station address of the Modbus slave
MODE	USInt	0	No remanente	True	True	False	Specifies a read, write, or diagnostic operation
DATA_ADDR	UDInt	0	No remanente	True	True	False	The Modbus data address
DATA_LEN	UInt	0	No remanente	True	True	False	The Modbus data length
▼ Output							
DONE	Bool	FALSE	No remanente	True	True	False	Boolean indicating completion without error
BUSY	Bool	FALSE	No remanente	True	True	False	Boolean indicating operation in progress

Owner	Project name	MODBUS_S7-1200_ABB_V13_SP1	Date	12/09/2017
Operator	Project path	C:\Users\integradora\Desktop\TESIS MODBUS\Documentos\S7 1200 - V20 MODBUS RS232\MODBUS_S7-1200_ABB_V13_SP1		
Designed By	Description 1st			
Checked By	Description 2nd	Language	es-ES	
Approved By	1st View	Version	Sheet 8 - 1	

A

Nombre	Tipo de datos	Valor predet.	Remanencia	Accesible desde HMI	Visible en HMI	Valor de ajuste	Comentario
ERROR	Bool	FALSE	No remanente	True	True	False	Boolean indicating completion with error
STATUS	Word	W#16#0	No remanente	True	True	False	Status or error code of the completed operation
▼ InOut							
DATA_PTR	Variant			False	False	False	Data area used to communicate with the Modbus slave
▼ Static							
▼ SEND_PTP_SFB							
SEND_PTP_SFB[0]	Array[0..11] of Byte		No remanente	False	False	False	
SEND_PTP_SFB[1]	Byte	16#0	No remanente	False	False	False	
SEND_PTP_SFB[2]	Byte	16#0	No remanente	False	False	False	
SEND_PTP_SFB[3]	Byte	16#0	No remanente	False	False	False	
SEND_PTP_SFB[4]	Byte	16#0	No remanente	False	False	False	
SEND_PTP_SFB[5]	Byte	16#0	No remanente	False	False	False	
SEND_PTP_SFB[6]	Byte	16#0	No remanente	False	False	False	
SEND_PTP_SFB[7]	Byte	16#0	No remanente	False	False	False	
SEND_PTP_SFB[8]	Byte	16#0	No remanente	False	False	False	
SEND_PTP_SFB[9]	Byte	16#0	No remanente	False	False	False	
SEND_PTP_SFB[10]	Byte	16#0	No remanente	False	False	False	
SEND_PTP_SFB[11]	Byte	16#0	No remanente	False	False	False	
▼ RCV_PTP_SFB							
RCV_PTP_SFB[0]	Array[0..11] of Byte		No remanente	False	False	False	
RCV_PTP_SFB[1]	Byte	16#0	No remanente	False	False	False	
RCV_PTP_SFB[2]	Byte	16#0	No remanente	False	False	False	
RCV_PTP_SFB[3]	Byte	16#0	No remanente	False	False	False	

B

C

D

E

F

Owner	Project name	MODBUS_S7-1200_ABB_V13_SP1	Date	12/09/2017
Operator	Project path	C:\Users\integradora\Desktop\TESIS MODBUS\Documentos\S7 1200 - V20 MODBUS RS232\MODBUS_S7-1200_ABB_V13_SP1		
Designed By	Description 1st			
Checked By	Description 2nd	Language	es-ES	
Approved By	1st View	Version	Sheet 8 - 2	

A

B

C

D

E

F

Nombre	Tipo de datos	Valor predet.	Remanencia	Accesible desde HMI	Visible en HMI	Valor de ajuste	Comentario
RCV_PTP_SFB[4]	Byte	16#0	No remanente	False	False	False	
RCV_PTP_SFB[5]	Byte	16#0	No remanente	False	False	False	
RCV_PTP_SFB[6]	Byte	16#0	No remanente	False	False	False	
RCV_PTP_SFB[7]	Byte	16#0	No remanente	False	False	False	
RCV_PTP_SFB[8]	Byte	16#0	No remanente	False	False	False	
RCV_PTP_SFB[9]	Byte	16#0	No remanente	False	False	False	
RCV_PTP_SFB[10]	Byte	16#0	No remanente	False	False	False	
RCV_PTP_SFB[11]	Byte	16#0	No remanente	False	False	False	
▼ RCV_RST_SFB	Array[0..9] of Byte		No remanente	False	False	False	
RCV_RST_SFB[0]	Byte	16#0	No remanente	False	False	False	
RCV_RST_SFB[1]	Byte	16#0	No remanente	False	False	False	
RCV_RST_SFB[2]	Byte	16#0	No remanente	False	False	False	
RCV_RST_SFB[3]	Byte	16#0	No remanente	False	False	False	
RCV_RST_SFB[4]	Byte	16#0	No remanente	False	False	False	
RCV_RST_SFB[5]	Byte	16#0	No remanente	False	False	False	
RCV_RST_SFB[6]	Byte	16#0	No remanente	False	False	False	
RCV_RST_SFB[7]	Byte	16#0	No remanente	False	False	False	
RCV_RST_SFB[8]	Byte	16#0	No remanente	False	False	False	
RCV_RST_SFB[9]	Byte	16#0	No remanente	False	False	False	
PF_FREQUENCY	Real	0.0	No remanente	False	False	False	
BLOCKED_PROC_TIMEOUT	Real	3.0	No remanente	True	True	False	
CURRENT_TIME_VALUE	UDInt	0	No remanente	False	False	False	
SAVED_TIME_VALUE	UDInt	0	No remanente	False	False	False	
SAVED_SLAVE_ADDR	Word	0	No remanente	False	False	False	

Owner	Project name	MODBUS_S7-1200_ABB_V13_SP1	Date	12/09/2017
Operator	Project path	C:\Users\integradora\Desktop\TESIS MODBUS\Documentos\S7 1200 - V20 MODBUS RS232\MODBUS_S7-1200_ABB_V13_SP1		
Designed By	Description 1st			
Checked By	Description 2nd	Language	es-ES	
Approved By	1st View	Version	Sheet 8 - 3	

1

2

3

4

A

Nombre	Tipo de datos	Valor predet.	Remanencia	Accesible desde HMI	Visible en HMI	Valor de ajuste	Comentario
SAVED_MODE	Word	0	No remanente	False	False	False	
SAVED_DATA_ADDR	DWord	0	No remanente	False	False	False	
SAVED_DATA_LEN	UInt	0	No remanente	False	False	False	
MB_STATE	UInt	0	No remanente	False	False	False	
COMM_SENT_COUNT	UInt	0	No remanente	False	False	False	
BYTE_COUNT	USInt	0	No remanente	False	False	False	
INIT_OK	Bool	FALSE	No remanente	False	False	False	
ACTIVE	Bool	FALSE	No remanente	False	False	False	
BROADCAST_FLAG	Bool	FALSE	No remanente	False	False	False	
EXTENDED_ADDRESSING	Bool	FALSE	No remanente	True	True	False	
SAVED_START_ADDR	UInt	0	No remanente	False	False	False	
TXBuf_Function_Offset	UDInt	0	No remanente	False	False	False	
TXBuf_Address_Offset	UDInt	0	No remanente	False	False	False	
TXBuf_Quantity_Offset	UDInt	0	No remanente	False	False	False	

B

C

D

E

F

Owner	Project name	MODBUS_S7-1200_ABB_V13_SP1	Date	12/09/2017
Operator	Project path	C:\Users\integradora\Desktop\TESIS MODBUS\Documentos\S7 1200 - V20 MODBUS RS232\MODBUS_S7-1200_ABB_V13_SP1		
	Location			
Designed By	Description 1st			
Checked By	Description 2nd	Language	es-ES	
Approved By	1st View	Version	Sheet 8 - 4	

# Bloques de programa / Bloques de sistema / Recursos de programa

## MB\_COMM\_LOAD [FB1080]

### MB\_COMM\_LOAD Propiedades

#### General

Nombre	MB_COMM_LOAD	Número	1080
Tipo	FB	Idioma	KOP
Numeración	automática		

#### Información

Título		Autor	SIMATIC
Comentario		Familia	MODBUS
Versión	2.1	ID personalizada	MB_CM_LD

Nombre	Tipo de datos	Valor predet.	Remanencia	Accesible desde HMI	Visible en HMI	Valor de ajuste	Comentario
▼ Input							
REQ	Bool	FALSE	No remanente	True	True	False	The enable to initiate a Modbus configuration operation
PORT	PORT	16#FFFF	No remanente	True	True	False	The PtP hardware address
BAUD	UDInt	0	No remanente	True	True	False	The baud rate of the PtP port
PARITY	UInt	0	No remanente	True	True	False	The parity of the PtP port
FLOW_CTRL	UInt	0	No remanente	True	True	False	Transmit and receive flow control
RTS_ON_DLY	UInt	0	No remanente	True	True	False	The enable time of RTS before sending the first character
RTS_OFF_DLY	UInt	0	No remanente	True	True	False	The enable time of RTS after sending the last character
RESP_TO	UInt	1000	No remanente	True	True	False	The time to wait for the Modbus slave to respond
▼ Output							
DONE	Bool	FALSE	No remanente	True	True	False	Boolean indicating completion without error
ERROR	Bool	FALSE	No remanente	True	True	False	Boolean indicating completion with error
STATUS	Word	W#16#0	No remanente	True	True	False	Status of the current operation
▼ InOut							

Owner	Project name	MODBUS_S7-1200_ABB_V13_SP1	Date	12/09/2017
Operator	Project path	C:\Users\integradora\Desktop\TESIS MODBUS\Documentos\S7 1200 - V20 MODBUS RS232\MODBUS_S7-1200_ABB_V13_SP1		
Designed By	Description 1st			
Checked By	Description 2nd	Language	es-ES	
Approved By	1st View	Version	Sheet 9 - 1	

Nombre	Tipo de datos	Valor predet.	Remanencia	Accesible desde HMI	Visible en HMI	Valor de ajuste	Comentario
▼ MB_DB	MB_BASE			False	False	False	The instance DB of the Modbus master or slave
Input							
Output							
InOut							
▼ Static							
S_PORT	UInt	16#FFFF	No remanente	False	False	False	
S_RESP_TO	UInt	1000	No remanente	False	False	False	
S_ICHAR_GA P	UInt	28	No remanente	False	False	False	
S_RETRIES	UInt	2	No remanente	False	False	False	
▼ Static							
ICHAR_GAP	UInt	0	No remanente	True	True	False	
RETRIES	UInt	2	No remanente	True	True	False	
WRREC_STATUS	Word	2	No remanente	True	True	False	
RDREC_STATUS	Word	2	No remanente	True	True	False	
SFC_STATUS	Word	2	No remanente	True	True	False	
▼ Port_CFG_SFB	Ar- ray[0..25] of Byte		No remanente	False	False	False	
Port_CFG_SFB[ 0]	Byte	16#0	No remanente	False	False	False	
Port_CFG_SFB[ 1]	Byte	16#0	No remanente	False	False	False	
Port_CFG_SFB[ 2]	Byte	16#0	No remanente	False	False	False	
Port_CFG_SFB[ 3]	Byte	16#0	No remanente	False	False	False	
Port_CFG_SFB[ 4]	Byte	16#0	No remanente	False	False	False	
Port_CFG_SFB[ 5]	Byte	16#0	No remanente	False	False	False	
Port_CFG_SFB[ 6]	Byte	16#0	No remanente	False	False	False	
Port_CFG_SFB[ 7]	Byte	16#0	No remanente	False	False	False	
Port_CFG_SFB[ 8]	Byte	16#0	No remanente	False	False	False	
Port_CFG_SFB[ 9]	Byte	16#0	No remanente	False	False	False	
Port_CFG_SFB[ 10]	Byte	16#0	No remanente	False	False	False	
Port_CFG_SFB[ 11]	Byte	16#0	No remanente	False	False	False	
Port_CFG_SFB[ 12]	Byte	16#0	No remanente	False	False	False	

Owner	Project name	MODBUS_S7-1200_ABB_V13_SP1	Date	12/09/2017
Operator	Project path	C:\Users\integradora\Desktop\TESIS MODBUS\Documentos\S7 1200 - V20 MODBUS RS232\MODBUS_S7-1200_ABB_V13_SP1		
	Location			
Designed By	Description 1st			
Checked By	Description 2nd	Language	es-ES	
Approved By	1st View	Version	Sheet 9 - 2	

1

2

3

4

A

Nombre	Tipo de datos	Valor predet.	Remanencia	Accesible desde HMI	Visible en HMI	Valor de ajuste	Comentario
Port_CFG_SFB[13]	Byte	16#0	No remanente	False	False	False	
Port_CFG_SFB[14]	Byte	16#0	No remanente	False	False	False	
Port_CFG_SFB[15]	Byte	16#0	No remanente	False	False	False	
Port_CFG_SFB[16]	Byte	16#0	No remanente	False	False	False	
Port_CFG_SFB[17]	Byte	16#0	No remanente	False	False	False	
Port_CFG_SFB[18]	Byte	16#0	No remanente	False	False	False	
Port_CFG_SFB[19]	Byte	16#0	No remanente	False	False	False	
Port_CFG_SFB[20]	Byte	16#0	No remanente	False	False	False	
Port_CFG_SFB[21]	Byte	16#0	No remanente	False	False	False	
Port_CFG_SFB[22]	Byte	16#0	No remanente	False	False	False	
Port_CFG_SFB[23]	Byte	16#0	No remanente	False	False	False	
Port_CFG_SFB[24]	Byte	16#0	No remanente	False	False	False	
Port_CFG_SFB[25]	Byte	16#0	No remanente	False	False	False	
▼ Send_CFG_SFB	Array[0..16] of Byte		No remanente	False	False	False	
Send_CFG_SFB[0]	Byte	16#0	No remanente	False	False	False	
Send_CFG_SFB[1]	Byte	16#0	No remanente	False	False	False	
Send_CFG_SFB[2]	Byte	16#0	No remanente	False	False	False	
Send_CFG_SFB[3]	Byte	16#0	No remanente	False	False	False	
Send_CFG_SFB[4]	Byte	16#0	No remanente	False	False	False	
Send_CFG_SFB[5]	Byte	16#0	No remanente	False	False	False	
Send_CFG_SFB[6]	Byte	16#0	No remanente	False	False	False	
Send_CFG_SFB[7]	Byte	16#0	No remanente	False	False	False	
Send_CFG_SFB[8]	Byte	16#0	No remanente	False	False	False	
Send_CFG_SFB[9]	Byte	16#0	No remanente	False	False	False	

B

C

D

E

F

Owner	Project name	MODBUS_S7-1200_ABB_V13_SP1	Date	12/09/2017
Operator	Project path	C:\Users\integradora\Desktop\TESIS MODBUS\Documentos\S7 1200 - V20 MODBUS RS232\MODBUS_S7-1200_ABB_V13_SP1		
Designed By	Description 1st			
Checked By	Description 2nd	Language	es-ES	
Approved By	1st View	Version	Sheet 9 - 3	



A

B

C

D

E

F

Nombre	Tipo de datos	Valor predet.	Remanencia	Accesible desde HMI	Visible en HMI	Valor de ajuste	Comentario
Send_CFG_SF B[10]	Byte	16#0	No remanente	False	False	False	
Send_CFG_SF B[11]	Byte	16#0	No remanente	False	False	False	
Send_CFG_SF B[12]	Byte	16#0	No remanente	False	False	False	
Send_CFG_SF B[13]	Byte	16#0	No remanente	False	False	False	
Send_CFG_SF B[14]	Byte	16#0	No remanente	False	False	False	
Send_CFG_SF B[15]	Byte	16#0	No remanente	False	False	False	
Send_CFG_SF B[16]	Byte	16#0	No remanente	False	False	False	
▼ Rcv_CFG_SFB	Array[0..60] of Byte		No remanente	False	False	False	
Rcv_CFG_SFB[0]	Byte	16#0	No remanente	False	False	False	
Rcv_CFG_SFB[1]	Byte	16#0	No remanente	False	False	False	
Rcv_CFG_SFB[2]	Byte	16#0	No remanente	False	False	False	
Rcv_CFG_SFB[3]	Byte	16#0	No remanente	False	False	False	
Rcv_CFG_SFB[4]	Byte	16#0	No remanente	False	False	False	
Rcv_CFG_SFB[5]	Byte	16#0	No remanente	False	False	False	
Rcv_CFG_SFB[6]	Byte	16#0	No remanente	False	False	False	
Rcv_CFG_SFB[7]	Byte	16#0	No remanente	False	False	False	
Rcv_CFG_SFB[8]	Byte	16#0	No remanente	False	False	False	
Rcv_CFG_SFB[9]	Byte	16#0	No remanente	False	False	False	
Rcv_CFG_SFB[10]	Byte	16#0	No remanente	False	False	False	
Rcv_CFG_SFB[11]	Byte	16#0	No remanente	False	False	False	
Rcv_CFG_SFB[12]	Byte	16#0	No remanente	False	False	False	
Rcv_CFG_SFB[13]	Byte	16#0	No remanente	False	False	False	
Rcv_CFG_SFB[14]	Byte	16#0	No remanente	False	False	False	
Rcv_CFG_SFB[15]	Byte	16#0	No remanente	False	False	False	

Owner	Project name	MODBUS_S7-1200_ABB_V13_SP1	Date	12/09/2017
Operator	Project path	C:\Users\integradora\Desktop\TESIS MODBUS\Documentos\S7 1200 - V20 MODBUS RS232\MODBUS_S7-1200_ABB_V13_SP1		
Designed By	Description 1st			
Checked By	Description 2nd	Language	es-ES	
Approved By	1st View	Version	Sheet 9 - 4	

1

2

3

4

A

Nombre	Tipo de datos	Valor predet.	Remanencia	Accesible desde HMI	Visible en HMI	Valor de ajuste	Comentario
Rcv_CFG_SFB[16]	Byte	16#0	No remanente	False	False	False	
Rcv_CFG_SFB[17]	Byte	16#0	No remanente	False	False	False	
Rcv_CFG_SFB[18]	Byte	16#0	No remanente	False	False	False	
Rcv_CFG_SFB[19]	Byte	16#0	No remanente	False	False	False	
Rcv_CFG_SFB[20]	Byte	16#0	No remanente	False	False	False	
Rcv_CFG_SFB[21]	Byte	16#0	No remanente	False	False	False	
Rcv_CFG_SFB[22]	Byte	16#0	No remanente	False	False	False	
Rcv_CFG_SFB[23]	Byte	16#0	No remanente	False	False	False	
Rcv_CFG_SFB[24]	Byte	16#0	No remanente	False	False	False	
Rcv_CFG_SFB[25]	Byte	16#0	No remanente	False	False	False	
Rcv_CFG_SFB[26]	Byte	16#0	No remanente	False	False	False	
Rcv_CFG_SFB[27]	Byte	16#0	No remanente	False	False	False	
Rcv_CFG_SFB[28]	Byte	16#0	No remanente	False	False	False	
Rcv_CFG_SFB[29]	Byte	16#0	No remanente	False	False	False	
Rcv_CFG_SFB[30]	Byte	16#0	No remanente	False	False	False	
Rcv_CFG_SFB[31]	Byte	16#0	No remanente	False	False	False	
Rcv_CFG_SFB[32]	Byte	16#0	No remanente	False	False	False	
Rcv_CFG_SFB[33]	Byte	16#0	No remanente	False	False	False	
Rcv_CFG_SFB[34]	Byte	16#0	No remanente	False	False	False	
Rcv_CFG_SFB[35]	Byte	16#0	No remanente	False	False	False	
Rcv_CFG_SFB[36]	Byte	16#0	No remanente	False	False	False	
Rcv_CFG_SFB[37]	Byte	16#0	No remanente	False	False	False	
Rcv_CFG_SFB[38]	Byte	16#0	No remanente	False	False	False	
Rcv_CFG_SFB[39]	Byte	16#0	No remanente	False	False	False	

B

C

D

E

F

Owner	Project name	MODBUS_S7-1200_ABB_V13_SP1	Date	12/09/2017
Operator	Project path	C:\Users\integradora\Desktop\TESIS MODBUS\Documentos\S7 1200 - V20 MODBUS RS232\MODBUS_S7-1200_ABB_V13_SP1		
Designed By	Description 1st			
Checked By	Description 2nd	Language	es-ES	
Approved By	1st View	Version	Sheet 9 - 5	

A

B

C

D

E

F

Nombre	Tipo de datos	Valor predet.	Remanencia	Accesible desde HMI	Visible en HMI	Valor de ajuste	Comentario
Rcv_CFG_SFB[40]	Byte	16#0	No remanente	False	False	False	
Rcv_CFG_SFB[41]	Byte	16#0	No remanente	False	False	False	
Rcv_CFG_SFB[42]	Byte	16#0	No remanente	False	False	False	
Rcv_CFG_SFB[43]	Byte	16#0	No remanente	False	False	False	
Rcv_CFG_SFB[44]	Byte	16#0	No remanente	False	False	False	
Rcv_CFG_SFB[45]	Byte	16#0	No remanente	False	False	False	
Rcv_CFG_SFB[46]	Byte	16#0	No remanente	False	False	False	
Rcv_CFG_SFB[47]	Byte	16#0	No remanente	False	False	False	
Rcv_CFG_SFB[48]	Byte	16#0	No remanente	False	False	False	
Rcv_CFG_SFB[49]	Byte	16#0	No remanente	False	False	False	
Rcv_CFG_SFB[50]	Byte	16#0	No remanente	False	False	False	
Rcv_CFG_SFB[51]	Byte	16#0	No remanente	False	False	False	
Rcv_CFG_SFB[52]	Byte	16#0	No remanente	False	False	False	
Rcv_CFG_SFB[53]	Byte	16#0	No remanente	False	False	False	
Rcv_CFG_SFB[54]	Byte	16#0	No remanente	False	False	False	
Rcv_CFG_SFB[55]	Byte	16#0	No remanente	False	False	False	
Rcv_CFG_SFB[56]	Byte	16#0	No remanente	False	False	False	
Rcv_CFG_SFB[57]	Byte	16#0	No remanente	False	False	False	
Rcv_CFG_SFB[58]	Byte	16#0	No remanente	False	False	False	
Rcv_CFG_SFB[59]	Byte	16#0	No remanente	False	False	False	
Rcv_CFG_SFB[60]	Byte	16#0	No remanente	False	False	False	
STOP_BITS	USInt	1	No remanente	True	True	False	

Owner	Project name	MODBUS_S7-1200_ABB_V13_SP1	Date	12/09/2017
	Operator	Project path C:\Users\integradora\Desktop\TESIS MODBUS\Documentos\S7 1200 - V20 MODBUS RS232\MODBUS_S7-1200_ABB_V13_SP1		
Designed By	Location			
Checked By	Description 1st	Language es-ES		
Approved By	Description 2nd	1st View	Version	Sheet 9 - 6

## **ANEXO E**

### **Programación del SCADA Visual Basic.Net**

```
Imports NationalInstruments
Imports NationalInstruments.Net
Imports NationalInstruments.UI.WindowsForms
Imports NationalInstruments.UI
Imports System.Globalization
```

```
Public Class MainForm
```

```
    Inherits System.Windows.Forms.Form
```

```
    Private Const TargetUrl As String = "opc://localhost/National Instruments.NIOPCServers.V5/MICRO850.
MICRO850_V20.VELOCIDAD" ' Direccion OPC de velocidad.
    Private Const TargetUrl1 As String = "opc://localhost/National Instruments.NIOPCServers.V5/MICRO850.
MICRO850_V20.STW_ENABLE" ' Direccion OPC de ENABLE.
    Private Const TargetUrl2 As String = "opc://localhost/National Instruments.NIOPCServers.V5/MICRO850.
MICRO850_V20.ENCENDIDO_APAGADO" ' Direccion OPC de MARCHA.
    Private Const TargetUrl3 As String = "opc://localhost/National Instruments.NIOPCServers.V5/MICRO850.
MICRO850_ACS355.PARO" ' Direccion OPC de PARO.
    Private Const TargetUrl4 As String = "opc://localhost/National Instruments.NIOPCServers.V5/MICRO850.
MICRO850_V20.REVERSA" ' Direccion OPC de REVERSA.
    Private Const TargetUrl5 As String = "opc://localhost/National Instruments.NIOPCServers.V5/MICRO850.
MICRO850_V20.HSW_ENABLE" ' Direccion OPC de VELOCIDAD_ENABLE.
```

```
    Private WithEvents waveformPlot As NationalInstruments.UI.WaveformPlot
    Private WithEvents xAxis As NationalInstruments.UI.XAxis
    Private WithEvents yAxis As NationalInstruments.UI.YAxis
    Private WithEvents statusTextBox As System.Windows.Forms.TextBox
    Private WithEvents statusLabel As System.Windows.Forms.Label
    Friend WithEvents Velocidad As NationalInstruments.UI.WindowsForms.Knob
    Friend WithEvents Label1 As System.Windows.Forms.Label
    Friend WithEvents Label2 As System.Windows.Forms.Label
    Friend WithEvents Label3 As System.Windows.Forms.Label
    Friend WithEvents Label4 As System.Windows.Forms.Label
    Friend WithEvents Label6 As System.Windows.Forms.Label
    Friend WithEvents Label7 As System.Windows.Forms.Label
    Friend WithEvents Label8 As System.Windows.Forms.Label
    Private WithEvents DataSocket1 As NationalInstruments.Net.DataSocket
    Friend WithEvents Switch1 As NationalInstruments.UI.WindowsForms.Switch
    Friend WithEvents Switch2 As NationalInstruments.UI.WindowsForms.Switch
    Friend WithEvents Marcha As NationalInstruments.UI.WindowsForms.Switch
    Friend WithEvents Switch5 As NationalInstruments.UI.WindowsForms.Switch
    Friend WithEvents DataSocket2 As NationalInstruments.Net.DataSocket
    Friend WithEvents DataSocket3 As NationalInstruments.Net.DataSocket
    Friend WithEvents DataSocket4 As NationalInstruments.Net.DataSocket
    Private Const BufferSize As Integer = 40
```

```
#Region " Windows Form Designer generated code "
```

```
    'Form overrides dispose to clean up the component list.
    Protected Overrides Sub Dispose(ByVal disposing As Boolean)
        If disposing Then
            If Not (components Is Nothing) Then
                components.Dispose()
            End If
        End If
        MyBase.Dispose(disposing)
    End Sub
```

```
    'Required by the Windows Form Designer
    Private components As System.ComponentModel.IContainer
```

```
    'NOTE: The following procedure is required by the Windows Form Designer
    'It can be modified using the Windows Form Designer.
    'Do not modify it using the code editor.
    Private WithEvents dataSocket As NationalInstruments.Net.DataSocket
    Private WithEvents timer As System.Windows.Forms.Timer
    Private WithEvents disconnectButton As System.Windows.Forms.Button
    Private WithEvents connectAutoUpdateButton As System.Windows.Forms.Button
    Private WithEvents dataSocketServer As NationalInstruments.Net.DataSocketServer
```

```
<System.Diagnostics.DebuggerStepThrough()> Private Sub InitializeComponent()
    Me.components = New System.ComponentModel.Container()
    Dim resources As System.ComponentModel.ComponentResourceManager = New System.ComponentModel.
ComponentResourceManager(GetType(MainForm))
    Me.dataSocket = New NationalInstruments.Net.DataSocket(Me.components)
```

```
Me.timer = New System.Windows.Forms.Timer(Me.components)
Me.disconnectButton = New System.Windows.Forms.Button()
Me.connectAutoUpdateButton = New System.Windows.Forms.Button()
Me.dataSocketServer = New NationalInstruments.Net.DataSocketServer(Me.components)
Me.waveformPlot = New NationalInstruments.UI.WaveformPlot()
Me.xAxis = New NationalInstruments.UI.XAxis()
Me.yAxis = New NationalInstruments.UI.YAxis()
Me.statusTextBox = New System.Windows.Forms.TextBox()
Me.statusTextLabel = New System.Windows.Forms.Label()
Me.Velocidad = New NationalInstruments.UI.WindowsForms.Knob()
Me.Label1 = New System.Windows.Forms.Label()
Me.Label2 = New System.Windows.Forms.Label()
Me.Label3 = New System.Windows.Forms.Label()
Me.Label4 = New System.Windows.Forms.Label()
Me.Label6 = New System.Windows.Forms.Label()
Me.Label7 = New System.Windows.Forms.Label()
Me.Label8 = New System.Windows.Forms.Label()
Me.DataSocket1 = New NationalInstruments.Net.DataSocket(Me.components)
Me.Switch1 = New NationalInstruments.UI.WindowsForms.Switch()
Me.Switch2 = New NationalInstruments.UI.WindowsForms.Switch()
Me.Marcha = New NationalInstruments.UI.WindowsForms.Switch()
Me.Switch5 = New NationalInstruments.UI.WindowsForms.Switch()
Me.DataSocket2 = New NationalInstruments.Net.DataSocket(Me.components)
Me.DataSocket3 = New NationalInstruments.Net.DataSocket(Me.components)
Me.DataSocket4 = New NationalInstruments.Net.DataSocket(Me.components)
CType(Me.dataSocket, System.ComponentModel.ISupportInitialize).BeginInit()
CType(Me.dataSocketServer, System.ComponentModel.ISupportInitialize).BeginInit()
CType(Me.Velocidad, System.ComponentModel.ISupportInitialize).BeginInit()
CType(Me.DataSocket1, System.ComponentModel.ISupportInitialize).BeginInit()
CType(Me.Switch1, System.ComponentModel.ISupportInitialize).BeginInit()
CType(Me.Switch2, System.ComponentModel.ISupportInitialize).BeginInit()
CType(Me.Marcha, System.ComponentModel.ISupportInitialize).BeginInit()
CType(Me.Switch5, System.ComponentModel.ISupportInitialize).BeginInit()
CType(Me.DataSocket2, System.ComponentModel.ISupportInitialize).BeginInit()
CType(Me.DataSocket3, System.ComponentModel.ISupportInitialize).BeginInit()
CType(Me.DataSocket4, System.ComponentModel.ISupportInitialize).BeginInit()
Me.SuspendLayout()
,
'dataSocket
,
Me.dataSocket.AutoConnect = False
,
'timer
,
Me.timer.Enabled = True
,
'disconnectButton
,
Me.disconnectButton.BackColor = System.Drawing.Color.Orange
Me.disconnectButton.FlatStyle = System.Windows.Forms.FlatStyle.System
Me.disconnectButton.Font = New System.Drawing.Font("Impact", 9.75!, System.Drawing.FontStyle.Regular,
System.Drawing.GraphicsUnit.Point, CType(0, Byte))
Me.disconnectButton.ForeColor = System.Drawing.Color.LawnGreen
Me.disconnectButton.Location = New System.Drawing.Point(691, 381)
Me.disconnectButton.Name = "disconnectButton"
Me.disconnectButton.Size = New System.Drawing.Size(169, 57)
Me.disconnectButton.TabIndex = 23
Me.disconnectButton.Text = "Disconnect"
Me.disconnectButton.UseVisualStyleBackColor = False
,
'connectAutoUpdateButton
,
Me.connectAutoUpdateButton.FlatStyle = System.Windows.Forms.FlatStyle.System
Me.connectAutoUpdateButton.Font = New System.Drawing.Font("Impact", 10.0!, System.Drawing.FontStyle.
Underline, System.Drawing.GraphicsUnit.Point, CType(0, Byte))
Me.connectAutoUpdateButton.ForeColor = System.Drawing.Color.LawnGreen
Me.connectAutoUpdateButton.Location = New System.Drawing.Point(691, 262)
Me.connectAutoUpdateButton.Name = "connectAutoUpdateButton"
Me.connectAutoUpdateButton.Size = New System.Drawing.Size(165, 57)
Me.connectAutoUpdateButton.TabIndex = 20
Me.connectAutoUpdateButton.Text = "Connect (Auto Update)"
,
'waveformPlot
,
```

```
Me.waveformPlot.XAxis = Me.xAxis
Me.waveformPlot.YAxis = Me.yAxis
'
'statusTextBox
'
Me.statusTextBox.Anchor = CType(((System.Windows.Forms.AnchorStyles.Top Or System.Windows.Forms.
AnchorStyles.Left) _
Or System.Windows.Forms.AnchorStyles.Right), System.Windows.Forms.AnchorStyles)
Me.statusTextBox.Location = New System.Drawing.Point(140, 82)
Me.statusTextBox.Name = "statusTextBox"
Me.statusTextBox.ReadOnly = True
Me.statusTextBox.Size = New System.Drawing.Size(1013, 20)
Me.statusTextBox.TabIndex = 18
'
'statusLabel
'
Me.statusTextLabel.Location = New System.Drawing.Point(55, 85)
Me.statusTextLabel.Name = "statusLabel"
Me.statusTextLabel.Size = New System.Drawing.Size(48, 23)
Me.statusTextLabel.TabIndex = 16
Me.statusTextLabel.Text = "Status:"
'
'Velocidad
'
Me.Velocidad.Location = New System.Drawing.Point(937, 415)
Me.Velocidad.Name = "Velocidad"
Me.Velocidad.Range = New NationalInstruments.UI.Range(0.0R, 50.0R)
Me.Velocidad.Size = New System.Drawing.Size(160, 152)
Me.Velocidad.TabIndex = 31
'
'Label1
'
Me.Label1.AutoSize = True
Me.Label1.Font = New System.Drawing.Font("Microsoft Sans Serif", 12.0!, System.Drawing.FontStyle.
Regular, System.Drawing.GraphicsUnit.Point, CType(0, Byte))
Me.Label1.ForeColor = System.Drawing.Color.DodgerBlue
Me.Label1.Location = New System.Drawing.Point(933, 197)
Me.Label1.Name = "Label1"
Me.Label1.Size = New System.Drawing.Size(163, 20)
Me.Label1.TabIndex = 32
Me.Label1.Text = "Cosigna de Velocidad"
'
'Label2
'
Me.Label2.AutoSize = True
Me.Label2.Font = New System.Drawing.Font("Impact", 20.0!, System.Drawing.FontStyle.Bold, System.
Drawing.GraphicsUnit.Point, CType(0, Byte))
Me.Label2.ForeColor = System.Drawing.Color.Crimson
Me.Label2.Location = New System.Drawing.Point(383, 27)
Me.Label2.Name = "Label2"
Me.Label2.Size = New System.Drawing.Size(412, 34)
Me.Label2.TabIndex = 33
Me.Label2.Text = "COMUNICACION MICRO850 A V_20"
'
'Label3
'
Me.Label3.AutoSize = True
Me.Label3.Font = New System.Drawing.Font("Microsoft Sans Serif", 12.0!, System.Drawing.FontStyle.
Regular, System.Drawing.GraphicsUnit.Point, CType(0, Byte))
Me.Label3.ForeColor = System.Drawing.Color.DodgerBlue
Me.Label3.Location = New System.Drawing.Point(167, 197)
Me.Label3.Name = "Label3"
Me.Label3.Size = New System.Drawing.Size(138, 20)
Me.Label3.TabIndex = 44
Me.Label3.Text = "Palabra de Mando"
'
'Label4
'
Me.Label4.AutoSize = True
Me.Label4.Font = New System.Drawing.Font("Microsoft Sans Serif", 10.0!, System.Drawing.FontStyle.Bold,
System.Drawing.GraphicsUnit.Point, CType(0, Byte))
Me.Label4.Location = New System.Drawing.Point(31, 508)
Me.Label4.Name = "Label4"
Me.Label4.Size = New System.Drawing.Size(72, 17)
```

```
Me.Label4.TabIndex = 45
Me.Label4.Text = "MARCHA"
'
'Label6
'
Me.Label6.AutoSize = True
Me.Label6.Font = New System.Drawing.Font("Microsoft Sans Serif", 10.0!, System.Drawing.FontStyle.Bold, System.Drawing.GraphicsUnit.Point, CType(0, Byte))
Me.Label6.Location = New System.Drawing.Point(359, 508)
Me.Label6.Name = "Label6"
Me.Label6.Size = New System.Drawing.Size(80, 17)
Me.Label6.TabIndex = 47
Me.Label6.Text = "REVERSA"
'
'Label7
'
Me.Label7.AutoSize = True
Me.Label7.Font = New System.Drawing.Font("Microsoft Sans Serif", 10.0!, System.Drawing.FontStyle.Bold, System.Drawing.GraphicsUnit.Point, CType(0, Byte))
Me.Label7.Location = New System.Drawing.Point(196, 381)
Me.Label7.Name = "Label7"
Me.Label7.Size = New System.Drawing.Size(68, 17)
Me.Label7.TabIndex = 48
Me.Label7.Text = "ENABLE"
'
'Label8
'
Me.Label8.AutoSize = True
Me.Label8.Font = New System.Drawing.Font("Microsoft Sans Serif", 10.0!, System.Drawing.FontStyle.Bold, System.Drawing.GraphicsUnit.Point, CType(0, Byte))
Me.Label8.Location = New System.Drawing.Point(984, 381)
Me.Label8.Name = "Label8"
Me.Label8.Size = New System.Drawing.Size(68, 17)
Me.Label8.TabIndex = 49
Me.Label8.Text = "ENABLE"
'
'DataSocket1
'
Me.DataSocket1.AccessMode = NationalInstruments.Net.AccessMode.ReadWriteAutoUpdate
Me.DataSocket1.AutoConnect = False
Me.DataSocket1.ReadMode = NationalInstruments.Net.ReadMode.Synchronous
Me.DataSocket1.Url = "opc://localhost/National Instruments.NIOPCServers.V5/MICRO850.MICRO850_ACS355.VEL" & _
"OCIDAD_ENABLE"
'
'Switch1
'
Me.Switch1.Location = New System.Drawing.Point(987, 249)
Me.Switch1.Name = "Switch1"
Me.Switch1.OffColor = System.Drawing.SystemColors.ActiveCaptionText
Me.Switch1.OnColor = System.Drawing.SystemColors.Highlight
Me.Switch1.Size = New System.Drawing.Size(64, 96)
Me.Switch1.SwitchStyle = NationalInstruments.UI.SwitchStyle.VerticalToggle3D
Me.Switch1.TabIndex = 50
'
'Switch2
'
Me.Switch2.Location = New System.Drawing.Point(199, 249)
Me.Switch2.Name = "Switch2"
Me.Switch2.OffColor = System.Drawing.SystemColors.ActiveCaptionText
Me.Switch2.OnColor = System.Drawing.SystemColors.MenuHighlight
Me.Switch2.Size = New System.Drawing.Size(64, 96)
Me.Switch2.SwitchStyle = NationalInstruments.UI.SwitchStyle.VerticalToggle3D
Me.Switch2.TabIndex = 51
'
'Marcha
'
Me.Marcha.Location = New System.Drawing.Point(34, 381)
Me.Marcha.Name = "Marcha"
Me.Marcha.OffColor = System.Drawing.SystemColors.ActiveCaptionText
Me.Marcha.OnColor = System.Drawing.SystemColors.Highlight
Me.Marcha.Size = New System.Drawing.Size(64, 96)
Me.Marcha.SwitchStyle = NationalInstruments.UI.SwitchStyle.VerticalToggle3D
Me.Marcha.TabIndex = 52
```



```

    '
    'Switch5
    '
    Me.Switch5.Location = New System.Drawing.Point(362, 381)
    Me.Switch5.Name = "Switch5"
    Me.Switch5.OffColor = System.Drawing.SystemColors.ActiveCaptionText
    Me.Switch5.OnColor = System.Drawing.SystemColors.MenuHighlight
    Me.Switch5.Size = New System.Drawing.Size(64, 96)
    Me.Switch5.SwitchStyle = NationalInstruments.UI.SwitchStyle.VerticalToggle3D
    Me.Switch5.TabIndex = 54
    '
    'MainForm
    '
    Me.AutoScaleDimensions = New System.Drawing.SizeF(96.0!, 96.0!)
    Me.AutoScaleMode = System.Windows.Forms.AutoScaleMode.Dpi
    Me.ClientSize = New System.Drawing.Size(1238, 593)
    Me.Controls.Add(Me.Switch5)
    Me.Controls.Add(Me.Marcha)
    Me.Controls.Add(Me.Switch2)
    Me.Controls.Add(Me.Switch1)
    Me.Controls.Add(Me.Label18)
    Me.Controls.Add(Me.Label17)
    Me.Controls.Add(Me.Label16)
    Me.Controls.Add(Me.Label14)
    Me.Controls.Add(Me.Label13)
    Me.Controls.Add(Me.Label12)
    Me.Controls.Add(Me.Label11)
    Me.Controls.Add(Me.Velocidad)
    Me.Controls.Add(Me.statusLabel)
    Me.Controls.Add(Me.statusTextBox)
    Me.Controls.Add(Me.disconnectButton)
    Me.Controls.Add(Me.connectAutoUpdateButton)
    Me.Icon = CType(resources.GetObject("$this.Icon"), System.Drawing.Icon)
    Me.MinimumSize = New System.Drawing.Size(500, 350)
    Me.Name = "MainForm"
    Me.Text = "DataSocket Writer"
    CType(Me.dataSocket, System.ComponentModel.ISupportInitialize).EndInit()
    CType(Me.dataSocketServer, System.ComponentModel.ISupportInitialize).EndInit()
    CType(Me.Velocidad, System.ComponentModel.ISupportInitialize).EndInit()
    CType(Me.DataSocket1, System.ComponentModel.ISupportInitialize).EndInit()
    CType(Me.Switch1, System.ComponentModel.ISupportInitialize).EndInit()
    CType(Me.Switch2, System.ComponentModel.ISupportInitialize).EndInit()
    CType(Me.Marcha, System.ComponentModel.ISupportInitialize).EndInit()
    CType(Me.Switch5, System.ComponentModel.ISupportInitialize).EndInit()
    CType(Me.DataSocket2, System.ComponentModel.ISupportInitialize).EndInit()
    CType(Me.DataSocket3, System.ComponentModel.ISupportInitialize).EndInit()
    CType(Me.DataSocket4, System.ComponentModel.ISupportInitialize).EndInit()
    Me.ResumeLayout(False)
    Me.PerformLayout()

End Sub

#End Region

<SThread()> _
Public Shared Sub Main()
    Application.EnableVisualStyles()
    Application.DoEvents()
    Application.Run(New MainForm())
End Sub

Public Sub New()
    MyBase.New()

    InitializeComponent()
    dataSocket.Data.Attributes.Add("Frequency", CType(Velocidad.Value, Double))
    dataSocket.Data.Attributes.Add("Timestamp", DateTime.Now)
    DataSocket1.Data.Attributes.Add("InVelocidad", CType(Switch1.Value, Boolean))
End Sub

Private Sub OnConnectAutoUpdateClick(ByVal sender As Object, ByVal e As System.EventArgs) Handles
connectAutoUpdateButton.Click

```

```
    If dataSocket.IsConnected Then
        dataSocket.Disconnect()
    End If

    dataSocket.Connect(TargetUrl, AccessMode.WriteAutoUpdate)
End Sub

Private Sub OnDisconnectClick(ByVal sender As Object, ByVal e As System.EventArgs) Handles
disconnectButton.Click
    dataSocket.Disconnect()
End Sub

Private Sub OnDataSocketConnectionStatusUpdated(ByVal sender As Object, ByVal e As NationalInstruments.
Net.ConnectionStatusUpdatedEventArgs) Handles dataSocket.ConnectionStatusUpdated
    statusTextBox.Text = e.Message
End Sub

Private Sub targetTextBox_TextChanged(sender As Object, e As EventArgs)

End Sub

Private Sub frequencyLabel_Click(sender As Object, e As EventArgs)

End Sub

Private Sub statusTextBox_TextChanged(sender As Object, e As EventArgs)

End Sub

Private Sub generateDataCheckBox_CheckedChanged(sender As Object, e As EventArgs)

End Sub

Private Sub Knob1_AfterChangeValue(sender As Object, e As AfterChangeNumericValueEventArgs) Handles
Velocidad.AfterChangeValue
    Dim frequencyValue As Double = CType(Velocidad.Value, Double)
    dataSocket.Data.Value = frequencyValue
    dataSocket.Data.Attributes.Item("Frequency").Value = frequencyValue
End Sub

Private Sub dataSocket_DataUpdated(sender As Object, e As DataUpdatedEventArgs) Handles dataSocket.
DataUpdated

End Sub

Private Sub Label1_Click(sender As Object, e As EventArgs) Handles Label1.Click

End Sub

Private Sub Label3_Click(sender As Object, e As EventArgs)

End Sub

Private Sub TextBox1_TextChanged(sender As Object, e As EventArgs)

End Sub

Private Sub Label3_Click_1(sender As Object, e As EventArgs) Handles Label3.Click

End Sub

Private Sub Label7_Click(sender As Object, e As EventArgs) Handles Label7.Click

End Sub

Private Sub VELOCIDAD_ENABLE_Click(sender As Object, e As EventArgs)
```

```
End Sub

Private Sub NumericEdit1_AfterChangeValue(sender As Object, e As AfterChangeNumericValueEventArgs)

End Sub

Private Sub statusTextBox_TextChanged_1(sender As Object, e As EventArgs) Handles statusTextBox.
    TextChanged
End Sub

Private Sub DataSocket1_DataUpdated(sender As Object, e As DataUpdatedEventArgs) Handles DataSocket1.
    DataUpdated
End Sub

Private Sub timer_Tick(sender As Object, e As EventArgs) Handles timer.Tick

End Sub

Private Sub Switch1_StateChanged(sender As Object, e As ActionEventArgs) Handles Switch1.StateChanged

    DataSocket1.Connect(TargetUr15, AccessMode.WriteAutoUpdate)
    If (Switch1.Value = True) Then
        DataSocket1.Data.Value = 1
    Else
        DataSocket1.Data.Value = 0
    End If

End Sub

Private Sub Label8_Click(sender As Object, e As EventArgs) Handles Label8.Click

End Sub

Private Sub Switch2_StateChanged(sender As Object, e As ActionEventArgs) Handles Switch2.StateChanged
    DataSocket2.Connect(TargetUr11, AccessMode.WriteAutoUpdate)
    If (Switch2.Value = True) Then
        DataSocket2.Data.Value = 1
    Else
        DataSocket2.Data.Value = 0
    End If

End Sub

Private Sub Switch5_StateChanged(sender As Object, e As ActionEventArgs) Handles Switch5.StateChanged
    DataSocket4.Connect(TargetUr14, AccessMode.WriteAutoUpdate)
    If (Switch5.Value = True) Then
        DataSocket4.Data.Value = 1
    Else
        DataSocket4.Data.Value = 0
    End If
End Sub

Private Sub Switch3_StateChanged(sender As Object, e As ActionEventArgs) Handles Marcha.StateChanged
    DataSocket3.Connect(TargetUr12, AccessMode.WriteAutoUpdate)
    If (Marcha.Value = True) Then
        DataSocket3.Data.Value = 1
    Else
        DataSocket3.Data.Value = 0
    End If

End Sub

End Class
```

```
Imports NationalInstruments
Imports NationalInstruments.Net
Imports NationalInstruments.UI.WindowsForms
Imports NationalInstruments.UI
Imports System.Globalization

Public Class MainForm
    Inherits System.Windows.Forms.Form

    Private Const TargetUrl As String = "opc://localhost/National Instruments.NIOPCServers.V5/MICRO850.
MICRO850_ACS355.VELOCIDAD" ' Direccion OPC de velocidad.
    Private Const TargetUrl1 As String = "opc://localhost/National Instruments.NIOPCServers.V5/MICRO850.
MICRO850_ACS355.CC_ENABLE" ' Direccion OPC de ENABLE.
    Private Const TargetUrl2 As String = "opc://localhost/National Instruments.NIOPCServers.V5/MICRO850.
MICRO850_ACS355.MARCHA" ' Direccion OPC de MARCHA.
    Private Const TargetUrl3 As String = "opc://localhost/National Instruments.NIOPCServers.V5/MICRO850.
MICRO850_ACS355.PARO" ' Direccion OPC de PARO.
    Private Const TargetUrl4 As String = "opc://localhost/National Instruments.NIOPCServers.V5/MICRO850.
MICRO850_ACS355.REVERSA" ' Direccion OPC de REVERSA.
    Private Const TargetUrl5 As String = "opc://localhost/National Instruments.NIOPCServers.V5/MICRO850.
MICRO850_ACS355.VELOCIDAD_ENABLE" ' Direccion OPC de VELOCIDAD_ENABLE.

    Private WithEvents waveformPlot As NationalInstruments.UI.WaveformPlot
    Private WithEvents xAxis As NationalInstruments.UI.XAxis
    Private WithEvents yAxis As NationalInstruments.UI.YAxis
    Private WithEvents statusTextBox As System.Windows.Forms.TextBox
    Private WithEvents statusLabel As System.Windows.Forms.Label
    Friend WithEvents Velocidad As NationalInstruments.UI.WindowsForms.Knob
    Friend WithEvents Label1 As System.Windows.Forms.Label
    Friend WithEvents Label2 As System.Windows.Forms.Label
    Friend WithEvents Label3 As System.Windows.Forms.Label
    Friend WithEvents Label4 As System.Windows.Forms.Label
    Friend WithEvents Label6 As System.Windows.Forms.Label
    Friend WithEvents Label7 As System.Windows.Forms.Label
    Friend WithEvents Label8 As System.Windows.Forms.Label
    Private WithEvents DataSocket1 As NationalInstruments.Net.DataSocket
    Friend WithEvents Switch1 As NationalInstruments.UI.WindowsForms.Switch
    Friend WithEvents Switch2 As NationalInstruments.UI.WindowsForms.Switch
    Friend WithEvents Marcha As NationalInstruments.UI.WindowsForms.Switch
    Friend WithEvents Switch5 As NationalInstruments.UI.WindowsForms.Switch
    Friend WithEvents DataSocket2 As NationalInstruments.Net.DataSocket
    Friend WithEvents DataSocket3 As NationalInstruments.Net.DataSocket
    Friend WithEvents DataSocket4 As NationalInstruments.Net.DataSocket
    Friend WithEvents Switch3 As NationalInstruments.UI.WindowsForms.Switch
    Friend WithEvents Label5 As System.Windows.Forms.Label
    Friend WithEvents DataSocket5 As NationalInstruments.Net.DataSocket
    Private Const BufferSize As Integer = 40

#Region " Windows Form Designer generated code "
    'Form overrides dispose to clean up the component list.
    Protected Overloads Overrides Sub Dispose(ByVal disposing As Boolean)
        If disposing Then
            If Not (components Is Nothing) Then
                components.Dispose()
            End If
        End If
        MyBase.Dispose(disposing)
    End Sub

    'Required by the Windows Form Designer
    Private components As System.ComponentModel.IContainer

    'NOTE: The following procedure is required by the Windows Form Designer
    'It can be modified using the Windows Form Designer.
    'Do not modify it using the code editor.
    Private WithEvents dataSocket As NationalInstruments.Net.DataSocket
    Private WithEvents timer As System.Windows.Forms.Timer
    Private WithEvents disconnectButton As System.Windows.Forms.Button
    Private WithEvents connectAutoUpdateButton As System.Windows.Forms.Button
    Private WithEvents dataSocketServer As NationalInstruments.Net.DataSocketServer

    <System.Diagnostics.DebuggerStepThrough()> Private Sub InitializeComponent()
        Me.components = New System.ComponentModel.Container()
```

```
Dim resources As System.ComponentModel.ComponentResourceManager = New System.ComponentModel.
ComponentResourceManager(GetType(MainForm))
Me.dataSocket = New NationalInstruments.Net.DataSocket(Me.components)
Me.timer = New System.Windows.Forms.Timer(Me.components)
Me.disconnectButton = New System.Windows.Forms.Button()
Me.connectAutoUpdateButton = New System.Windows.Forms.Button()
Me.dataSocketServer = New NationalInstruments.Net.DataSocketServer(Me.components)
Me.waveformPlot = New NationalInstruments.UI.WaveformPlot()
Me.xAxis = New NationalInstruments.UI.XAxis()
Me.yAxis = New NationalInstruments.UI.YAxis()
Me.statusTextBox = New System.Windows.Forms.TextBox()
Me.statusTextLabel = New System.Windows.Forms.Label()
Me.Velocidad = New NationalInstruments.UI.WindowsForms.Knob()
Me.Label1 = New System.Windows.Forms.Label()
Me.Label2 = New System.Windows.Forms.Label()
Me.Label3 = New System.Windows.Forms.Label()
Me.Label4 = New System.Windows.Forms.Label()
Me.Label6 = New System.Windows.Forms.Label()
Me.Label7 = New System.Windows.Forms.Label()
Me.Label8 = New System.Windows.Forms.Label()
Me.DataSocket1 = New NationalInstruments.Net.DataSocket(Me.components)
Me.Switch1 = New NationalInstruments.UI.WindowsForms.Switch()
Me.Switch2 = New NationalInstruments.UI.WindowsForms.Switch()
Me.Marcha = New NationalInstruments.UI.WindowsForms.Switch()
Me.Switch5 = New NationalInstruments.UI.WindowsForms.Switch()
Me.DataSocket2 = New NationalInstruments.Net.DataSocket(Me.components)
Me.DataSocket3 = New NationalInstruments.Net.DataSocket(Me.components)
Me.DataSocket4 = New NationalInstruments.Net.DataSocket(Me.components)
Me.Switch3 = New NationalInstruments.UI.WindowsForms.Switch()
Me.Label5 = New System.Windows.Forms.Label()
Me.DataSocket5 = New NationalInstruments.Net.DataSocket(Me.components)
CType(Me.dataSocket, System.ComponentModel.ISupportInitialize).BeginInit()
CType(Me.dataSocketServer, System.ComponentModel.ISupportInitialize).BeginInit()
CType(Me.Velocidad, System.ComponentModel.ISupportInitialize).BeginInit()
CType(Me.DataSocket1, System.ComponentModel.ISupportInitialize).BeginInit()
CType(Me.Switch1, System.ComponentModel.ISupportInitialize).BeginInit()
CType(Me.Switch2, System.ComponentModel.ISupportInitialize).BeginInit()
CType(Me.Marcha, System.ComponentModel.ISupportInitialize).BeginInit()
CType(Me.Switch5, System.ComponentModel.ISupportInitialize).BeginInit()
CType(Me.DataSocket2, System.ComponentModel.ISupportInitialize).BeginInit()
CType(Me.DataSocket3, System.ComponentModel.ISupportInitialize).BeginInit()
CType(Me.DataSocket4, System.ComponentModel.ISupportInitialize).BeginInit()
CType(Me.Switch3, System.ComponentModel.ISupportInitialize).BeginInit()
CType(Me.DataSocket5, System.ComponentModel.ISupportInitialize).BeginInit()
Me.SuspendLayout()
'
'dataSocket
'
Me.dataSocket.AutoConnect = False
'
'timer
'
Me.timer.Enabled = True
'
'disconnectButton
'
Me.disconnectButton.BackColor = System.Drawing.Color.Orange
Me.disconnectButton.FlatStyle = System.Windows.Forms.FlatStyle.System
Me.disconnectButton.Font = New System.Drawing.Font("Impact", 9.75!, System.Drawing.FontStyle.Regular,
System.Drawing.GraphicsUnit.Point, CType(0, Byte))
Me.disconnectButton.ForeColor = System.Drawing.Color.LawnGreen
Me.disconnectButton.Location = New System.Drawing.Point(691, 381)
Me.disconnectButton.Name = "disconnectButton"
Me.disconnectButton.Size = New System.Drawing.Size(169, 57)
Me.disconnectButton.TabIndex = 23
Me.disconnectButton.Text = "Disconnect"
Me.disconnectButton.UseVisualStyleBackColor = False
'
'connectAutoUpdateButton
'
Me.connectAutoUpdateButton.FlatStyle = System.Windows.Forms.FlatStyle.System
Me.connectAutoUpdateButton.Font = New System.Drawing.Font("Impact", 10.0!, System.Drawing.FontStyle.
Underline, System.Drawing.GraphicsUnit.Point, CType(0, Byte))
Me.connectAutoUpdateButton.ForeColor = System.Drawing.Color.LawnGreen
```

```
Me.connectAutoUpdateButton.Location = New System.Drawing.Point(691, 262)
Me.connectAutoUpdateButton.Name = "connectAutoUpdateButton"
Me.connectAutoUpdateButton.Size = New System.Drawing.Size(165, 57)
Me.connectAutoUpdateButton.TabIndex = 20
Me.connectAutoUpdateButton.Text = "Connect (Auto Update)"
'
'waveformPlot
'
Me.waveformPlot.XAxis = Me.xAxis
Me.waveformPlot.YAxis = Me.yAxis
'
'statusTextBox
'
Me.statusTextBox.Anchor = CType(((System.Windows.Forms.AnchorStyles.Top Or System.Windows.Forms.
AnchorStyles.Left) _
    Or System.Windows.Forms.AnchorStyles.Right), System.Windows.Forms.AnchorStyles)
Me.statusTextBox.Location = New System.Drawing.Point(140, 82)
Me.statusTextBox.Name = "statusTextBox"
Me.statusTextBox.ReadOnly = True
Me.statusTextBox.Size = New System.Drawing.Size(1013, 20)
Me.statusTextBox.TabIndex = 18
'
'statusLabel
'
Me.statusLabel.Location = New System.Drawing.Point(55, 85)
Me.statusLabel.Name = "statusLabel"
Me.statusLabel.Size = New System.Drawing.Size(48, 23)
Me.statusLabel.TabIndex = 16
Me.statusLabel.Text = "Status:"
'
'Velocidad
'
Me.Velocidad.Location = New System.Drawing.Point(937, 415)
Me.Velocidad.Name = "Velocidad"
Me.Velocidad.Range = New NationalInstruments.UI.Range(0.0R, 50.0R)
Me.Velocidad.Size = New System.Drawing.Size(160, 152)
Me.Velocidad.TabIndex = 31
'
'Label1
'
Me.Label1.AutoSize = True
Me.Label1.Font = New System.Drawing.Font("Microsoft Sans Serif", 12.0!, System.Drawing.FontStyle.
Regular, System.Drawing.GraphicsUnit.Point, CType(0, Byte))
Me.Label1.ForeColor = System.Drawing.Color.DodgerBlue
Me.Label1.Location = New System.Drawing.Point(933, 197)
Me.Label1.Name = "Label1"
Me.Label1.Size = New System.Drawing.Size(163, 20)
Me.Label1.TabIndex = 32
Me.Label1.Text = "Cosigna de Velocidad"
'
'Label2
'
Me.Label2.AutoSize = True
Me.Label2.Font = New System.Drawing.Font("Impact", 20.0!, System.Drawing.FontStyle.Bold, System.
Drawing.GraphicsUnit.Point, CType(0, Byte))
Me.Label2.ForeColor = System.Drawing.Color.Crimson
Me.Label2.Location = New System.Drawing.Point(383, 27)
Me.Label2.Name = "Label2"
Me.Label2.Size = New System.Drawing.Size(398, 34)
Me.Label2.TabIndex = 33
Me.Label2.Text = "COMUNICACION MICRO850 A ABB"
'
'Label3
'
Me.Label3.AutoSize = True
Me.Label3.Font = New System.Drawing.Font("Microsoft Sans Serif", 12.0!, System.Drawing.FontStyle.
Regular, System.Drawing.GraphicsUnit.Point, CType(0, Byte))
Me.Label3.ForeColor = System.Drawing.Color.DodgerBlue
Me.Label3.Location = New System.Drawing.Point(167, 197)
Me.Label3.Name = "Label3"
Me.Label3.Size = New System.Drawing.Size(138, 20)
Me.Label3.TabIndex = 44
Me.Label3.Text = "Palabra de Mando"
```

```
'Label4
,
Me.Label4.AutoSize = True
Me.Label4.Font = New System.Drawing.Font("Microsoft Sans Serif", 10.0!, System.Drawing.FontStyle.Bold, System.Drawing.GraphicsUnit.Point, CType(0, Byte))
Me.Label4.Location = New System.Drawing.Point(31, 508)
Me.Label4.Name = "Label4"
Me.Label4.Size = New System.Drawing.Size(72, 17)
Me.Label4.TabIndex = 45
Me.Label4.Text = "MARCHA"
,
'Label6
,
Me.Label6.AutoSize = True
Me.Label6.Font = New System.Drawing.Font("Microsoft Sans Serif", 10.0!, System.Drawing.FontStyle.Bold, System.Drawing.GraphicsUnit.Point, CType(0, Byte))
Me.Label6.Location = New System.Drawing.Point(359, 508)
Me.Label6.Name = "Label6"
Me.Label6.Size = New System.Drawing.Size(80, 17)
Me.Label6.TabIndex = 47
Me.Label6.Text = "REVERSA"
,
'Label7
,
Me.Label7.AutoSize = True
Me.Label7.Font = New System.Drawing.Font("Microsoft Sans Serif", 10.0!, System.Drawing.FontStyle.Bold, System.Drawing.GraphicsUnit.Point, CType(0, Byte))
Me.Label7.Location = New System.Drawing.Point(196, 336)
Me.Label7.Name = "Label7"
Me.Label7.Size = New System.Drawing.Size(68, 17)
Me.Label7.TabIndex = 48
Me.Label7.Text = "ENABLE"
,
'Label8
,
Me.Label8.AutoSize = True
Me.Label8.Font = New System.Drawing.Font("Microsoft Sans Serif", 10.0!, System.Drawing.FontStyle.Bold, System.Drawing.GraphicsUnit.Point, CType(0, Byte))
Me.Label8.Location = New System.Drawing.Point(984, 381)
Me.Label8.Name = "Label8"
Me.Label8.Size = New System.Drawing.Size(68, 17)
Me.Label8.TabIndex = 49
Me.Label8.Text = "ENABLE"
,
'DataSocket1
,
Me.DataSocket1.AccessMode = NationalInstruments.Net.AccessMode.ReadWriteAutoUpdate
Me.DataSocket1.AutoConnect = False
Me.DataSocket1.ReadMode = NationalInstruments.Net.ReadMode.Synchronous
Me.DataSocket1.Url = "opc://localhost/National Instruments.NIOPCServers.V5/MICRO850.MICRO850_ACS355.
VEL" & _
"OCIDAD_ENABLE"
,
'Switch1
,
Me.Switch1.Location = New System.Drawing.Point(987, 249)
Me.Switch1.Name = "Switch1"
Me.Switch1.OffColor = System.Drawing.SystemColors.ActiveCaptionText
Me.Switch1.OnColor = System.Drawing.SystemColors.Highlight
Me.Switch1.Size = New System.Drawing.Size(64, 96)
Me.Switch1.SwitchStyle = NationalInstruments.UI.SwitchStyle.VerticalToggle3D
Me.Switch1.TabIndex = 50
,
'Switch2
,
Me.Switch2.Location = New System.Drawing.Point(199, 237)
Me.Switch2.Name = "Switch2"
Me.Switch2.OffColor = System.Drawing.SystemColors.ActiveCaptionText
Me.Switch2.OnColor = System.Drawing.SystemColors.MenuHighlight
Me.Switch2.Size = New System.Drawing.Size(64, 96)
Me.Switch2.SwitchStyle = NationalInstruments.UI.SwitchStyle.VerticalToggle3D
Me.Switch2.TabIndex = 51
,
'Marcha
```

```
,
Me.Marcha.Location = New System.Drawing.Point(34, 381)
Me.Marcha.Name = "Marcha"
Me.Marcha.OffColor = System.Drawing.SystemColors.ActiveCaptionText
Me.Marcha.OnColor = System.Drawing.SystemColors.Highlight
Me.Marcha.Size = New System.Drawing.Size(64, 96)
Me.Marcha.SwitchStyle = NationalInstruments.UI.SwitchStyle.VerticalToggle3D
Me.Marcha.TabIndex = 52
,
'Switch5
,
Me.Switch5.Location = New System.Drawing.Point(362, 381)
Me.Switch5.Name = "Switch5"
Me.Switch5.OffColor = System.Drawing.SystemColors.ActiveCaptionText
Me.Switch5.OnColor = System.Drawing.SystemColors.MenuHighlight
Me.Switch5.Size = New System.Drawing.Size(64, 96)
Me.Switch5.SwitchStyle = NationalInstruments.UI.SwitchStyle.VerticalToggle3D
Me.Switch5.TabIndex = 54
,
'Switch3
,
Me.Switch3.Location = New System.Drawing.Point(199, 381)
Me.Switch3.Name = "Switch3"
Me.Switch3.OffColor = System.Drawing.SystemColors.ActiveCaptionText
Me.Switch3.OnColor = System.Drawing.SystemColors.Highlight
Me.Switch3.Size = New System.Drawing.Size(64, 96)
Me.Switch3.SwitchStyle = NationalInstruments.UI.SwitchStyle.VerticalToggle3D
Me.Switch3.TabIndex = 55
,
'Label5
,
Me.Label5.AutoSize = True
Me.Label5.Font = New System.Drawing.Font("Microsoft Sans Serif", 10.0!, System.Drawing.FontStyle.Bold,
, System.Drawing.GraphicsUnit.Point, CType(0, Byte))
Me.Label5.Location = New System.Drawing.Point(212, 508)
Me.Label5.Name = "Label5"
Me.Label5.Size = New System.Drawing.Size(51, 17)
Me.Label5.TabIndex = 56
Me.Label5.Text = "PARO"
,
'MainForm
,
Me.AutoScaleDimensions = New System.Drawing.SizeF(96.0!, 96.0!)
Me.AutoScaleMode = System.Windows.Forms.AutoScaleMode.Dpi
Me.ClientSize = New System.Drawing.Size(1238, 593)
Me.Controls.Add(Me.Label5)
Me.Controls.Add(Me.Switch3)
Me.Controls.Add(Me.Switch5)
Me.Controls.Add(Me.Marcha)
Me.Controls.Add(Me.Switch2)
Me.Controls.Add(Me.Switch1)
Me.Controls.Add(Me.Label8)
Me.Controls.Add(Me.Label7)
Me.Controls.Add(Me.Label6)
Me.Controls.Add(Me.Label4)
Me.Controls.Add(Me.Label3)
Me.Controls.Add(Me.Label2)
Me.Controls.Add(Me.Label1)
Me.Controls.Add(Me.Velocidad)
Me.Controls.Add(Me.statusLabel)
Me.Controls.Add(Me.statusTextBox)
Me.Controls.Add(Me.disconnectButton)
Me.Controls.Add(Me.connectAutoUpdateButton)
Me.Icon = CType(resources.GetObject("$this.Icon"), System.Drawing.Icon)
Me.MinimumSize = New System.Drawing.Size(500, 350)
Me.Name = "MainForm"
Me.Text = "DataSocket Writer"
CType(Me.dataSocket, System.ComponentModel.ISupportInitialize).EndInit()
CType(Me.dataSocketServer, System.ComponentModel.ISupportInitialize).EndInit()
CType(Me.Velocidad, System.ComponentModel.ISupportInitialize).EndInit()
CType(Me.DataSocket1, System.ComponentModel.ISupportInitialize).EndInit()
CType(Me.Switch1, System.ComponentModel.ISupportInitialize).EndInit()
CType(Me.Switch2, System.ComponentModel.ISupportInitialize).EndInit()
CType(Me.Marcha, System.ComponentModel.ISupportInitialize).EndInit()
```



```
CType(Me.Switch5, System.ComponentModel.ISupportInitialize).EndInit()  
CType(Me.DataSocket2, System.ComponentModel.ISupportInitialize).EndInit()  
CType(Me.DataSocket3, System.ComponentModel.ISupportInitialize).EndInit()  
CType(Me.DataSocket4, System.ComponentModel.ISupportInitialize).EndInit()  
CType(Me.Switch3, System.ComponentModel.ISupportInitialize).EndInit()  
CType(Me.DataSocket5, System.ComponentModel.ISupportInitialize).EndInit()  
Me.ResumeLayout(False)  
Me.PerformLayout()
```

End Sub

#End Region

```
<STAThread> _  
Public Shared Sub Main()  
    Application.EnableVisualStyles()  
    Application.DoEvents()  
    Application.Run(New MainForm())  
End Sub
```

```
Public Sub New()  
    MyBase.New()
```

```
    InitializeComponent()  
    dataSocket.Data.Attributes.Add("Frequency", CType(Velocidad.Value, Double))  
    dataSocket.Data.Attributes.Add("Timestamp", DateTime.Now)  
    DataSocket1.Data.Attributes.Add("InVelocidad", CType(Switch1.Value, Boolean))  
End Sub
```

```
Private Sub OnConnectAutoUpdateClick(ByVal sender As Object, ByVal e As System.EventArgs) Handles  
connectAutoUpdateButton.Click  
    If dataSocket.IsConnected Then  
        dataSocket.Disconnect()  
    End If  
  
    dataSocket.Connect(TargetUrl, AccessMode.WriteAutoUpdate)  
End Sub
```

```
Private Sub OnDisconnectClick(ByVal sender As Object, ByVal e As System.EventArgs) Handles  
disconnectButton.Click  
    dataSocket.Disconnect()  
End Sub
```

```
Private Sub OnDataSocketConnectionStatusUpdated(ByVal sender As Object, ByVal e As NationalInstruments.  
Net.ConnectionStatusUpdatedEventArgs) Handles dataSocket.ConnectionStatusUpdated  
    statusTextBox.Text = e.Message  
End Sub
```

```
Private Sub targetTextBox_TextChanged(sender As Object, e As EventArgs)  
  
End Sub
```

```
Private Sub frequencyLabel_Click(sender As Object, e As EventArgs)  
  
End Sub
```

```
Private Sub statusTextBox_TextChanged(sender As Object, e As EventArgs)  
  
End Sub
```

```
Private Sub generateDataCheckBox_CheckedChanged(sender As Object, e As EventArgs)  
  
End Sub
```

```
Private Sub Knob1_AfterChangeValue(sender As Object, e As AfterChangeNumericValueEventArgs) Handles  
Velocidad.AfterChangeValue
```

```
    Dim frequencyValue As Double = CType(Velocidad.Value, Double)
    dataSocket.Data.Value = frequencyValue
    dataSocket.Data.Attributes.Item("Frequency").Value = frequencyValue
End Sub

Private Sub dataSocket_DataUpdated(sender As Object, e As DataUpdatedEventArgs) Handles dataSocket.
DataUpdated
End Sub

Private Sub Label1_Click(sender As Object, e As EventArgs) Handles Label1.Click
End Sub

Private Sub Label3_Click(sender As Object, e As EventArgs)
End Sub

Private Sub TextBox1_TextChanged(sender As Object, e As EventArgs)
End Sub

Private Sub Label3_Click_1(sender As Object, e As EventArgs) Handles Label3.Click
End Sub

Private Sub Label7_Click(sender As Object, e As EventArgs) Handles Label7.Click
End Sub

Private Sub VELOCIDAD_ENABLE_Click(sender As Object, e As EventArgs)
End Sub

Private Sub NumericEdit1_AfterChangeValue(sender As Object, e As AfterChangeNumericValueEventArgs)
End Sub

Private Sub statusTextBox_TextChanged_1(sender As Object, e As EventArgs) Handles statusTextBox.
TextChanged
End Sub

Private Sub DataSocket1_DataUpdated(sender As Object, e As DataUpdatedEventArgs) Handles DataSocket1.
DataUpdated
End Sub

Private Sub timer_Tick(sender As Object, e As EventArgs) Handles timer.Tick
End Sub

Private Sub Switch1_StateChanged(sender As Object, e As ActionEventArgs) Handles Switch1.StateChanged
    DataSocket1.Connect(TargetUr15, AccessMode.WriteAutoUpdate)
    If (Switch1.Value = True) Then
        DataSocket1.Data.Value = 1
    Else
        DataSocket1.Data.Value = 0
    End If
End Sub

Private Sub Label8_Click(sender As Object, e As EventArgs) Handles Label8.Click
End Sub

Private Sub Switch2_StateChanged(sender As Object, e As ActionEventArgs) Handles Switch2.StateChanged
    DataSocket2.Connect(TargetUr11, AccessMode.WriteAutoUpdate)
    If (Switch2.Value = True) Then
        DataSocket2.Data.Value = 1
    End If
End Sub
```

```
    Else
        DataSocket2.Data.Value = 0
    End If

End Sub

Private Sub Switch5_StateChanged(sender As Object, e As EventArgs) Handles Switch5.StateChanged
    DataSocket4.Connect(TargetUr14, AccessMode.WriteAutoUpdate)
    If (Switch5.Value = True) Then
        DataSocket4.Data.Value = 1
    Else
        DataSocket4.Data.Value = 0
    End If
End Sub

Private Sub Switch3_StateChanged(sender As Object, e As EventArgs) Handles Marcha.StateChanged
    DataSocket3.Connect(TargetUr12, AccessMode.WriteAutoUpdate)
    If (Marcha.Value = True) Then
        DataSocket3.Data.Value = 1
    Else
        DataSocket3.Data.Value = 0
    End If
End Sub

Private Sub Switch3_StateChanged_1(sender As Object, e As EventArgs) Handles Switch3.StateChanged
    DataSocket5.Connect(TargetUr13, AccessMode.WriteAutoUpdate)
    If (Marcha.Value = True) Then
        DataSocket5.Data.Value = 1
    Else
        DataSocket5.Data.Value = 0
    End If
End Sub

End Class
```

```
Imports NationalInstruments
Imports NationalInstruments.Net
Imports NationalInstruments.UI.WindowsForms
Imports NationalInstruments.UI
Imports System.Globalization
```

```
Public Class MainForm
```

```
    Inherits System.Windows.Forms.Form
```

```
    Private Const TargetUrl As String = "opc://localhost/National Instruments.NIOPCServers.V5/S7-1200.
    SINAMICS-V20.VELOCIDAD_DESEADA" ' Direccion OPC de velocidad.
    Private Const TargetUrl1 As String = "opc://localhost/National Instruments.NIOPCServers.V5/S7-1200.
    SINAMICS-V20.SWT_ENABLE" ' Direccion OPC de ENABLE.
    Private Const TargetUrl2 As String = "opc://localhost/National Instruments.NIOPCServers.V5/S7-1200.
    SINAMICS-V20.ENCENDIDO_APAGADO" ' Direccion OPC de MARCHA.
    Private Const TargetUrl3 As String = "opc://localhost/National Instruments.NIOPCServers.V5/S7-1200.
    SINAMICS-V20.INICIO_MASTER" ' Direccion INICIO_MASTER.
    Private Const TargetUrl4 As String = "opc://localhost/National Instruments.NIOPCServers.V5/S7-1200.
    SINAMICS-V20.REVERSA" ' Direccion OPC de REVERSA.
    Private Const TargetUrl5 As String = "opc://localhost/National Instruments.NIOPCServers.V5/S7-1200.
    SINAMICS-V20.HSW_ENABLE" ' Direccion OPC de VELOCIDAD_ENABLE.
    Private Const TargetUrl6 As String = "opc://localhost/National Instruments.NIOPCServers.V5/S7-1200.
    SINAMICS-V20.INICIO_TRAMA" ' Direccion OPC de INICIO_TRAMA.
```

```
    Private WithEvents waveformPlot As NationalInstruments.UI.WaveformPlot
    Private WithEvents xAxis As NationalInstruments.UI.XAxis
    Private WithEvents yAxis As NationalInstruments.UI.YAxis
    Private WithEvents statusTextBox As System.Windows.Forms.TextBox
    Private WithEvents statusLabel As System.Windows.Forms.Label
    Friend WithEvents Velocidad As NationalInstruments.UI.WindowsForms.Knob
    Friend WithEvents Label1 As System.Windows.Forms.Label
    Friend WithEvents Label2 As System.Windows.Forms.Label
    Friend WithEvents Label3 As System.Windows.Forms.Label
    Friend WithEvents Label4 As System.Windows.Forms.Label
    Friend WithEvents Label6 As System.Windows.Forms.Label
    Friend WithEvents Label7 As System.Windows.Forms.Label
    Friend WithEvents Label8 As System.Windows.Forms.Label
    Private WithEvents DataSocket1 As NationalInstruments.Net.DataSocket
    Friend WithEvents Switch1 As NationalInstruments.UI.WindowsForms.Switch
    Friend WithEvents Switch2 As NationalInstruments.UI.WindowsForms.Switch
    Friend WithEvents Marcha As NationalInstruments.UI.WindowsForms.Switch
    Friend WithEvents Switch5 As NationalInstruments.UI.WindowsForms.Switch
    Friend WithEvents DataSocket2 As NationalInstruments.Net.DataSocket
    Friend WithEvents DataSocket3 As NationalInstruments.Net.DataSocket
    Friend WithEvents DataSocket4 As NationalInstruments.Net.DataSocket
    Friend WithEvents Switch3 As NationalInstruments.UI.WindowsForms.Switch
    Friend WithEvents Label5 As System.Windows.Forms.Label
    Friend WithEvents Switch4 As NationalInstruments.UI.WindowsForms.Switch
    Friend WithEvents Label9 As System.Windows.Forms.Label
    Friend WithEvents DataSocket5 As NationalInstruments.Net.DataSocket
    Friend WithEvents DataSocket6 As NationalInstruments.Net.DataSocket
    Friend WithEvents DataSocket7 As NationalInstruments.Net.DataSocket
    Private Const bufferSize As Integer = 40
```

```
#Region " Windows Form Designer generated code "
```

```
    'Form overrides dispose to clean up the component list.
    Protected Overloads Overrides Sub Dispose(ByVal disposing As Boolean)
        If disposing Then
            If Not (components Is Nothing) Then
                components.Dispose()
            End If
        End If
        MyBase.Dispose(disposing)
    End Sub
```

```
    'Required by the Windows Form Designer
    Private components As System.ComponentModel.IContainer
```

```
    'NOTE: The following procedure is required by the Windows Form Designer
    'It can be modified using the Windows Form Designer.
    'Do not modify it using the code editor.
    Private WithEvents dataSocket As NationalInstruments.Net.DataSocket
    Private WithEvents timer As System.Windows.Forms.Timer
```

```

Private WithEvents disconnectButton As System.Windows.Forms.Button
Private WithEvents connectAutoUpdateButton As System.Windows.Forms.Button
Private WithEvents dataSocketServer As NationalInstruments.Net.DataSocketServer

<System.Diagnostics.DebuggerStepThrough()> Private Sub InitializeComponent()
    Me.components = New System.ComponentModel.Container()
    Dim resources As System.ComponentModel.ComponentResourceManager = New System.ComponentModel.
ComponentResourceManager(GetType(MainForm))
    Me.dataSocket = New NationalInstruments.Net.DataSocket(Me.components)
    Me.timer = New System.Windows.Forms.Timer(Me.components)
    Me.disconnectButton = New System.Windows.Forms.Button()
    Me.connectAutoUpdateButton = New System.Windows.Forms.Button()
    Me.dataSocketServer = New NationalInstruments.Net.DataSocketServer(Me.components)
    Me.waveformPlot = New NationalInstruments.UI.WaveformPlot()
    Me.xAxis = New NationalInstruments.UI.XAxis()
    Me.yAxis = New NationalInstruments.UI.YAxis()
    Me.statusTextBox = New System.Windows.Forms.TextBox()
    Me.statusLabel = New System.Windows.Forms.Label()
    Me.Velocidad = New NationalInstruments.UI.WindowsForms.Knob()
    Me.Label1 = New System.Windows.Forms.Label()
    Me.Label2 = New System.Windows.Forms.Label()
    Me.Label3 = New System.Windows.Forms.Label()
    Me.Label4 = New System.Windows.Forms.Label()
    Me.Label6 = New System.Windows.Forms.Label()
    Me.Label7 = New System.Windows.Forms.Label()
    Me.Label8 = New System.Windows.Forms.Label()
    Me.DataSocket1 = New NationalInstruments.Net.DataSocket(Me.components)
    Me.Switch1 = New NationalInstruments.UI.WindowsForms.Switch()
    Me.Switch2 = New NationalInstruments.UI.WindowsForms.Switch()
    Me.Marcha = New NationalInstruments.UI.WindowsForms.Switch()
    Me.Switch5 = New NationalInstruments.UI.WindowsForms.Switch()
    Me.DataSocket2 = New NationalInstruments.Net.DataSocket(Me.components)
    Me.DataSocket3 = New NationalInstruments.Net.DataSocket(Me.components)
    Me.DataSocket4 = New NationalInstruments.Net.DataSocket(Me.components)
    Me.Switch3 = New NationalInstruments.UI.WindowsForms.Switch()
    Me.Label5 = New System.Windows.Forms.Label()
    Me.Switch4 = New NationalInstruments.UI.WindowsForms.Switch()
    Me.Label9 = New System.Windows.Forms.Label()
    Me.DataSocket5 = New NationalInstruments.Net.DataSocket(Me.components)
    Me.DataSocket6 = New NationalInstruments.Net.DataSocket(Me.components)
    Me.DataSocket7 = New NationalInstruments.Net.DataSocket(Me.components)
    CType(Me.dataSocket, System.ComponentModel.ISupportInitialize).BeginInit()
    CType(Me.dataSocketServer, System.ComponentModel.ISupportInitialize).BeginInit()
    CType(Me.Velocidad, System.ComponentModel.ISupportInitialize).BeginInit()
    CType(Me.DataSocket1, System.ComponentModel.ISupportInitialize).BeginInit()
    CType(Me.Switch1, System.ComponentModel.ISupportInitialize).BeginInit()
    CType(Me.Switch2, System.ComponentModel.ISupportInitialize).BeginInit()
    CType(Me.Marcha, System.ComponentModel.ISupportInitialize).BeginInit()
    CType(Me.Switch5, System.ComponentModel.ISupportInitialize).BeginInit()
    CType(Me.DataSocket2, System.ComponentModel.ISupportInitialize).BeginInit()
    CType(Me.DataSocket3, System.ComponentModel.ISupportInitialize).BeginInit()
    CType(Me.DataSocket4, System.ComponentModel.ISupportInitialize).BeginInit()
    CType(Me.Switch3, System.ComponentModel.ISupportInitialize).BeginInit()
    CType(Me.Switch4, System.ComponentModel.ISupportInitialize).BeginInit()
    CType(Me.DataSocket5, System.ComponentModel.ISupportInitialize).BeginInit()
    CType(Me.DataSocket6, System.ComponentModel.ISupportInitialize).BeginInit()
    CType(Me.DataSocket7, System.ComponentModel.ISupportInitialize).BeginInit()
    Me.SuspendLayout()
    '
    'dataSocket
    '
    Me.dataSocket.AutoConnect = False
    '
    'timer
    '
    Me.timer.Enabled = True
    '
    'disconnectButton
    '
    Me.disconnectButton.BackColor = System.Drawing.Color.Orange
    Me.disconnectButton.FlatStyle = System.Windows.Forms.FlatStyle.System
    Me.disconnectButton.Font = New System.Drawing.Font("Impact", 9.75!, System.Drawing.FontStyle.Regular,
System.Drawing.GraphicsUnit.Point, CType(0, Byte))
    Me.disconnectButton.ForeColor = System.Drawing.Color.LawnGreen

```

```
Me.disconnectButton.Location = New System.Drawing.Point(837, 510)
Me.disconnectButton.Name = "disconnectButton"
Me.disconnectButton.Size = New System.Drawing.Size(169, 57)
Me.disconnectButton.TabIndex = 23
Me.disconnectButton.Text = "Disconnect"
Me.disconnectButton.UseVisualStyleBackColor = False
,
'connectAutoUpdateButton
,
Me.connectAutoUpdateButton.FlatStyle = System.Windows.Forms.FlatStyle.System
Me.connectAutoUpdateButton.Font = New System.Drawing.Font("Impact", 10.0!, System.Drawing.FontStyle. Underline, System.Drawing.GraphicsUnit.Point, CType(0, Byte))
Me.connectAutoUpdateButton.ForeColor = System.Drawing.Color.LawnGreen
Me.connectAutoUpdateButton.Location = New System.Drawing.Point(837, 175)
Me.connectAutoUpdateButton.Name = "connectAutoUpdateButton"
Me.connectAutoUpdateButton.Size = New System.Drawing.Size(165, 57)
Me.connectAutoUpdateButton.TabIndex = 20
Me.connectAutoUpdateButton.Text = "Connect (Auto Update)"
,
'waveformPlot
,
Me.waveformPlot.XAxis = Me.xAxis
Me.waveformPlot.YAxis = Me.yAxis
,
'statusTextBox
,
Me.statusTextBox.Anchor = CType(((System.Windows.Forms.AnchorStyles.Top Or System.Windows.Forms. AnchorStyles.Left) _
Or System.Windows.Forms.AnchorStyles.Right), System.Windows.Forms.AnchorStyles)
Me.statusTextBox.Location = New System.Drawing.Point(140, 82)
Me.statusTextBox.Name = "statusTextBox"
Me.statusTextBox.ReadOnly = True
Me.statusTextBox.Size = New System.Drawing.Size(1013, 20)
Me.statusTextBox.TabIndex = 18
,
'statusLabel
,
Me.statusTextLabel.Location = New System.Drawing.Point(55, 85)
Me.statusTextLabel.Name = "statusLabel"
Me.statusTextLabel.Size = New System.Drawing.Size(48, 23)
Me.statusTextLabel.TabIndex = 16
Me.statusTextLabel.Text = "Status:"
,
'Velocidad
,
Me.Velocidad.Location = New System.Drawing.Point(1050, 381)
Me.Velocidad.Name = "Velocidad"
Me.Velocidad.Range = New NationalInstruments.UI.Range(0.0R, 50.0R)
Me.Velocidad.Size = New System.Drawing.Size(160, 152)
Me.Velocidad.TabIndex = 31
,
'Label1
,
Me.Label1.AutoSize = True
Me.Label1.Font = New System.Drawing.Font("Microsoft Sans Serif", 12.0!, System.Drawing.FontStyle. Regular, System.Drawing.GraphicsUnit.Point, CType(0, Byte))
Me.Label1.ForeColor = System.Drawing.Color.DodgerBlue
Me.Label1.Location = New System.Drawing.Point(854, 356)
Me.Label1.Name = "Label1"
Me.Label1.Size = New System.Drawing.Size(163, 20)
Me.Label1.TabIndex = 32
Me.Label1.Text = "Cosigna de Velocidad"
,
'Label2
,
Me.Label2.AutoSize = True
Me.Label2.Font = New System.Drawing.Font("Impact", 20.0!, System.Drawing.FontStyle.Bold, System. Drawing.GraphicsUnit.Point, CType(0, Byte))
Me.Label2.ForeColor = System.Drawing.Color.Crimson
Me.Label2.Location = New System.Drawing.Point(383, 27)
Me.Label2.Name = "Label2"
Me.Label2.Size = New System.Drawing.Size(382, 34)
Me.Label2.TabIndex = 33
Me.Label2.Text = "COMUNICACION S7-1200 A V_20"
```

```
'
'Label3
'
Me.Label3.AutoSize = True
Me.Label3.Font = New System.Drawing.Font("Microsoft Sans Serif", 12.0!, System.Drawing.FontStyle.Regular, System.Drawing.GraphicsUnit.Point, CType(0, Byte))
Me.Label3.ForeColor = System.Drawing.Color.DodgerBlue
Me.Label3.Location = New System.Drawing.Point(168, 356)
Me.Label3.Name = "Label3"
Me.Label3.Size = New System.Drawing.Size(138, 20)
Me.Label3.TabIndex = 44
Me.Label3.Text = "Palabra de Mando"
'
'Label4
'
Me.Label4.AutoSize = True
Me.Label4.Font = New System.Drawing.Font("Microsoft Sans Serif", 10.0!, System.Drawing.FontStyle.Bold, System.Drawing.GraphicsUnit.Point, CType(0, Byte))
Me.Label4.Location = New System.Drawing.Point(37, 402)
Me.Label4.Name = "Label4"
Me.Label4.Size = New System.Drawing.Size(72, 17)
Me.Label4.TabIndex = 45
Me.Label4.Text = "MARCHA"
'
'Label6
'
Me.Label6.AutoSize = True
Me.Label6.Font = New System.Drawing.Font("Microsoft Sans Serif", 10.0!, System.Drawing.FontStyle.Bold, System.Drawing.GraphicsUnit.Point, CType(0, Byte))
Me.Label6.Location = New System.Drawing.Point(36, 550)
Me.Label6.Name = "Label6"
Me.Label6.Size = New System.Drawing.Size(80, 17)
Me.Label6.TabIndex = 47
Me.Label6.Text = "REVERSA"
'
'Label7
'
Me.Label7.AutoSize = True
Me.Label7.Font = New System.Drawing.Font("Microsoft Sans Serif", 10.0!, System.Drawing.FontStyle.Bold, System.Drawing.GraphicsUnit.Point, CType(0, Byte))
Me.Label7.Location = New System.Drawing.Point(37, 239)
Me.Label7.Name = "Label7"
Me.Label7.Size = New System.Drawing.Size(68, 17)
Me.Label7.TabIndex = 48
Me.Label7.Text = "ENABLE"
'
'Label8
'
Me.Label8.AutoSize = True
Me.Label8.Font = New System.Drawing.Font("Microsoft Sans Serif", 10.0!, System.Drawing.FontStyle.Bold, System.Drawing.GraphicsUnit.Point, CType(0, Byte))
Me.Label8.Location = New System.Drawing.Point(1142, 280)
Me.Label8.Name = "Label8"
Me.Label8.Size = New System.Drawing.Size(68, 17)
Me.Label8.TabIndex = 49
Me.Label8.Text = "ENABLE"
'
'DataSocket1
'
Me.DataSocket1.AccessMode = NationalInstruments.Net.AccessMode.ReadWriteAutoUpdate
Me.DataSocket1.AutoConnect = False
Me.DataSocket1.ReadMode = NationalInstruments.Net.ReadMode.Synchronous
Me.DataSocket1.Url = "opc://localhost/National Instruments.NIOPCServers.V5/MICRO850.MICRO850_ACS355.VEL" & _
"OCIDAD_ENABLE"
'
'Switch1
'
Me.Switch1.Location = New System.Drawing.Point(1145, 136)
Me.Switch1.Name = "Switch1"
Me.Switch1.OffColor = System.Drawing.SystemColors.ActiveCaptionText
Me.Switch1.OnColor = System.Drawing.SystemColors.Highlight
Me.Switch1.Size = New System.Drawing.Size(64, 96)
Me.Switch1.SwitchStyle = NationalInstruments.UI.SwitchStyle.VerticalToggle3D
```

```
Me.Switch1.TabIndex = 50
'
'Switch2
'
Me.Switch2.Location = New System.Drawing.Point(39, 121)
Me.Switch2.Name = "Switch2"
Me.Switch2.OffColor = System.Drawing.SystemColors.ActiveCaptionText
Me.Switch2.OnColor = System.Drawing.SystemColors.MenuHighlight
Me.Switch2.Size = New System.Drawing.Size(64, 96)
Me.Switch2.SwitchStyle = NationalInstruments.UI.SwitchStyle.VerticalToggle3D
Me.Switch2.TabIndex = 51
'
'Marcha
'
Me.Marcha.Location = New System.Drawing.Point(39, 280)
Me.Marcha.Name = "Marcha"
Me.Marcha.OffColor = System.Drawing.SystemColors.ActiveCaptionText
Me.Marcha.OnColor = System.Drawing.SystemColors.Highlight
Me.Marcha.Size = New System.Drawing.Size(64, 96)
Me.Marcha.SwitchStyle = NationalInstruments.UI.SwitchStyle.VerticalToggle3D
Me.Marcha.TabIndex = 52
'
'Switch5
'
Me.Switch5.Location = New System.Drawing.Point(41, 442)
Me.Switch5.Name = "Switch5"
Me.Switch5.OffColor = System.Drawing.SystemColors.ActiveCaptionText
Me.Switch5.OnColor = System.Drawing.SystemColors.MenuHighlight
Me.Switch5.Size = New System.Drawing.Size(64, 96)
Me.Switch5.SwitchStyle = NationalInstruments.UI.SwitchStyle.VerticalToggle3D
Me.Switch5.TabIndex = 54
'
'Switch3
'
Me.Switch3.Location = New System.Drawing.Point(534, 381)
Me.Switch3.Name = "Switch3"
Me.Switch3.OffColor = System.Drawing.SystemColors.ActiveCaptionText
Me.Switch3.OnColor = System.Drawing.SystemColors.Highlight
Me.Switch3.Size = New System.Drawing.Size(64, 96)
Me.Switch3.SwitchStyle = NationalInstruments.UI.SwitchStyle.VerticalToggle3D
Me.Switch3.TabIndex = 55
'
'Label5
'
Me.Label5.AutoSize = True
Me.Label5.Font = New System.Drawing.Font("Microsoft Sans Serif", 10.0!, System.Drawing.FontStyle.Bold, System.Drawing.GraphicsUnit.Point, CType(0, Byte))
Me.Label5.Location = New System.Drawing.Point(511, 318)
Me.Label5.Name = "Label5"
Me.Label5.Size = New System.Drawing.Size(120, 17)
Me.Label5.TabIndex = 56
Me.Label5.Text = "INICIAR TRAMA"
'
'Switch4
'
Me.Switch4.Location = New System.Drawing.Point(534, 175)
Me.Switch4.Name = "Switch4"
Me.Switch4.OffColor = System.Drawing.SystemColors.ActiveCaptionText
Me.Switch4.OnColor = System.Drawing.SystemColors.Highlight
Me.Switch4.Size = New System.Drawing.Size(64, 96)
Me.Switch4.SwitchStyle = NationalInstruments.UI.SwitchStyle.VerticalToggle3D
Me.Switch4.TabIndex = 57
'
'Label9
'
Me.Label9.AutoSize = True
Me.Label9.Font = New System.Drawing.Font("Microsoft Sans Serif", 10.0!, System.Drawing.FontStyle.Bold, System.Drawing.GraphicsUnit.Point, CType(0, Byte))
Me.Label9.Location = New System.Drawing.Point(511, 521)
Me.Label9.Name = "Label9"
Me.Label9.Size = New System.Drawing.Size(74, 17)
Me.Label9.TabIndex = 58
Me.Label9.Text = "MODBUS"
```



```

'MainForm
'
Me.AutoScaleDimensions = New System.Drawing.SizeF(96.0!, 96.0!)
Me.AutoScaleMode = System.Windows.Forms.AutoScaleMode.Dpi
Me.ClientSize = New System.Drawing.Size(1238, 593)
Me.Controls.Add(Me.Label9)
Me.Controls.Add(Me.Switch4)
Me.Controls.Add(Me.Label5)
Me.Controls.Add(Me.Switch3)
Me.Controls.Add(Me.Switch5)
Me.Controls.Add(Me.Marcha)
Me.Controls.Add(Me.Switch2)
Me.Controls.Add(Me.Switch1)
Me.Controls.Add(Me.Label8)
Me.Controls.Add(Me.Label7)
Me.Controls.Add(Me.Label6)
Me.Controls.Add(Me.Label4)
Me.Controls.Add(Me.Label3)
Me.Controls.Add(Me.Label2)
Me.Controls.Add(Me.Label1)
Me.Controls.Add(Me.Velocidad)
Me.Controls.Add(Me.statusLabel)
Me.Controls.Add(Me.statusTextBox)
Me.Controls.Add(Me.disconnectButton)
Me.Controls.Add(Me.connectAutoUpdateButton)
Me.Icon = CType(resources.GetObject($"{this.Icon}"), System.Drawing.Icon)
Me.MinimumSize = New System.Drawing.Size(500, 350)
Me.Name = "MainForm"
Me.Text = "DataSocket Writer"
CType(Me.dataSocket, System.ComponentModel.ISupportInitialize).EndInit()
CType(Me.dataSocketServer, System.ComponentModel.ISupportInitialize).EndInit()
CType(Me.Velocidad, System.ComponentModel.ISupportInitialize).EndInit()
CType(Me.DataSocket1, System.ComponentModel.ISupportInitialize).EndInit()
CType(Me.Switch1, System.ComponentModel.ISupportInitialize).EndInit()
CType(Me.Switch2, System.ComponentModel.ISupportInitialize).EndInit()
CType(Me.Marcha, System.ComponentModel.ISupportInitialize).EndInit()
CType(Me.Switch5, System.ComponentModel.ISupportInitialize).EndInit()
CType(Me.DataSocket2, System.ComponentModel.ISupportInitialize).EndInit()
CType(Me.DataSocket3, System.ComponentModel.ISupportInitialize).EndInit()
CType(Me.DataSocket4, System.ComponentModel.ISupportInitialize).EndInit()
CType(Me.Switch3, System.ComponentModel.ISupportInitialize).EndInit()
CType(Me.Switch4, System.ComponentModel.ISupportInitialize).EndInit()
CType(Me.DataSocket5, System.ComponentModel.ISupportInitialize).EndInit()
CType(Me.DataSocket6, System.ComponentModel.ISupportInitialize).EndInit()
CType(Me.DataSocket7, System.ComponentModel.ISupportInitialize).EndInit()
Me.ResumeLayout(False)
Me.PerformLayout()

```

End Sub

#End Region

```

<STAThread(> _
Public Shared Sub Main()
    Application.EnableVisualStyles()
    Application.DoEvents()
    Application.Run(New MainForm())
End Sub

Public Sub New()
    MyBase.New()

    InitializeComponent()
    dataSocket.Data.Attributes.Add("Frequency", CType(Velocidad.Value, Double))
    dataSocket.Data.Attributes.Add("Timestamp", DateTime.Now)
    DataSocket1.Data.Attributes.Add("InVelocidad", CType(Switch1.Value, Boolean))
End Sub

```

```

Private Sub OnConnectAutoUpdateClick(ByVal sender As Object, ByVal e As System.EventArgs) Handles
connectAutoUpdateButton.Click
    If dataSocket.IsConnected Then
        dataSocket.Disconnect()
    End If
End Sub

```



```
End If

    dataSocket.Connect(TargetUrl, AccessMode.WriteAutoUpdate)
End Sub

Private Sub OnDisconnectClick(ByVal sender As Object, ByVal e As System.EventArgs) Handles disconnectButton.Click
    dataSocket.Disconnect()
End Sub

Private Sub OnDataSocketConnectionStatusUpdated(ByVal sender As Object, ByVal e As NationalInstruments.
Net.ConnectionStatusUpdatedEventArgs) Handles dataSocket.ConnectionStatusUpdated
    statusTextBox.Text = e.Message
End Sub

Private Sub targetTextBox_TextChanged(sender As Object, e As EventArgs)

End Sub

Private Sub frequencyLabel_Click(sender As Object, e As EventArgs)

End Sub

Private Sub statusTextBox_TextChanged(sender As Object, e As EventArgs)

End Sub

Private Sub generateDataCheckBox_CheckedChanged(sender As Object, e As EventArgs)

End Sub

Private Sub Knob1_AfterChangeValue(sender As Object, e As AfterChangeNumericValueEventArgs) Handles Velocidad.AfterChangeValue
    Dim frequencyValue As Double = CType(Velocidad.Value, Double)
    dataSocket.Data.Value = frequencyValue
    dataSocket.Data.Attributes.Item("Frequency").Value = frequencyValue
End Sub

Private Sub dataSocket_DataUpdated(sender As Object, e As DataUpdatedEventArgs) Handles dataSocket.
DataUpdated

End Sub

Private Sub Label1_Click(sender As Object, e As EventArgs) Handles Label1.Click

End Sub

Private Sub Label3_Click(sender As Object, e As EventArgs)

End Sub

Private Sub TextBox1_TextChanged(sender As Object, e As EventArgs)

End Sub

Private Sub Label3_Click_1(sender As Object, e As EventArgs) Handles Label3.Click

End Sub

Private Sub Label7_Click(sender As Object, e As EventArgs) Handles Label7.Click

End Sub

Private Sub VELOCIDAD_ENABLE_Click(sender As Object, e As EventArgs)

End Sub
```

```
Private Sub NumericEdit1_AfterChangeValue(sender As Object, e As AfterChangeNumericValueEventArgs)

End Sub

Private Sub statusTextBox_TextChanged_1(sender As Object, e As EventArgs) Handles statusTextBox.
    TextChanged
End Sub

Private Sub DataSocket1_DataUpdated(sender As Object, e As DataUpdatedEventArgs) Handles DataSocket1.
    DataUpdated
End Sub

Private Sub timer_Tick(sender As Object, e As EventArgs) Handles timer.Tick

End Sub

Private Sub Switch1_StateChanged(sender As Object, e As ActionEventArgs) Handles Switch1.StateChanged

    DataSocket1.Connect(TargetUr15, AccessMode.WriteAutoUpdate)
    If (Switch1.Value = True) Then
        DataSocket1.Data.Value = 1
    Else
        DataSocket1.Data.Value = 0
    End If

End Sub

Private Sub Label8_Click(sender As Object, e As EventArgs) Handles Label8.Click

End Sub

Private Sub Switch2_StateChanged(sender As Object, e As ActionEventArgs) Handles Switch2.StateChanged
    DataSocket2.Connect(TargetUr11, AccessMode.WriteAutoUpdate)
    If (Switch2.Value = True) Then
        DataSocket2.Data.Value = 1
    Else
        DataSocket2.Data.Value = 0
    End If

End Sub

Private Sub Switch5_StateChanged(sender As Object, e As ActionEventArgs) Handles Switch5.StateChanged
    DataSocket4.Connect(TargetUr14, AccessMode.WriteAutoUpdate)
    If (Switch5.Value = True) Then
        DataSocket4.Data.Value = 1
    Else
        DataSocket4.Data.Value = 0
    End If
End Sub

Private Sub Switch4_StateChanged(sender As Object, e As ActionEventArgs) Handles Switch4.StateChanged
    DataSocket5.Connect(TargetUr13, AccessMode.WriteAutoUpdate)
    If (Switch4.Value = True) Then
        DataSocket5.Data.Value = 1
    Else
        DataSocket5.Data.Value = 0
    End If
End Sub

Private Sub Switch3_StateChanged_1(sender As Object, e As ActionEventArgs) Handles Switch3.StateChanged
    DataSocket7.Connect(TargetUr16, AccessMode.WriteAutoUpdate)
    If (Switch3.Value = True) Then
        DataSocket7.Data.Value = 1
    Else
        DataSocket7.Data.Value = 0
    End If
End Sub

Private Sub Marcha_StateChanged(sender As Object, e As ActionEventArgs) Handles Marcha.StateChanged
    DataSocket6.Connect(TargetUr12, AccessMode.WriteAutoUpdate)
```

```
    If (Marcha.Value = True) Then
        DataSocket6.Data.Value = 1
    Else
        DataSocket6.Data.Value = 0
    End If
End Sub
End Class
```

```
Imports NationalInstruments
Imports NationalInstruments.Net
Imports NationalInstruments.UI.WindowsForms
Imports NationalInstruments.UI
Imports System.Globalization

Public Class MainForm
    Inherits System.Windows.Forms.Form

    Private Const TargetUrl As String = "opc://localhost/National Instruments.NIOPCServers.V5/S7-1200.ABB-ACS355.VELOCIDAD_DESEADA" ' Direccion OPC de velocidad.
    Private Const TargetUrl1 As String = "opc://localhost/National Instruments.NIOPCServers.V5/S7-1200.ABB-ACS355.STW_ENABLE" ' Direccion OPC de ENABLE.
    Private Const TargetUrl2 As String = "opc://localhost/National Instruments.NIOPCServers.V5/S7-1200.ABB-ACS355.MARCHA" ' Direccion OPC de MARCHA.
    Private Const TargetUrl3 As String = "opc://localhost/National Instruments.NIOPCServers.V5/S7-1200.ABB-ACS355.INICIO_MASTER" ' Direccion INICIO_MASTER.
    Private Const TargetUrl4 As String = "opc://localhost/National Instruments.NIOPCServers.V5/S7-1200.ABB-ACS355.REVERSA" ' Direccion OPC de REVERSA.
    Private Const TargetUrl5 As String = "opc://localhost/National Instruments.NIOPCServers.V5/S7-1200.ABB-ACS355.HSW_ENABLE" ' Direccion OPC de VELOCIDAD_ENABLE.
    Private Const TargetUrl6 As String = "opc://localhost/National Instruments.NIOPCServers.V5/S7-1200.ABB-ACS355.INICIO_TRAMA" ' Direccion OPC de INICIO_TRAMA.
    Private Const TargetUrl7 As String = "opc://localhost/National Instruments.NIOPCServers.V5/S7-1200.ABB-ACS355.PARO" ' Direccion OPC de PARO.

    Private WithEvents waveformPlot As NationalInstruments.UI.WaveformPlot
    Private WithEvents xAxis As NationalInstruments.UI.XAxis
    Private WithEvents yAxis As NationalInstruments.UI.YAxis
    Private WithEvents statusTextBox As System.Windows.Forms.TextBox
    Private WithEvents statusLabel As System.Windows.Forms.Label
    Friend WithEvents Velocidad As NationalInstruments.UI.WindowsForms.Knob
    Friend WithEvents Label1 As System.Windows.Forms.Label
    Friend WithEvents Label2 As System.Windows.Forms.Label
    Friend WithEvents Label3 As System.Windows.Forms.Label
    Friend WithEvents Label4 As System.Windows.Forms.Label
    Friend WithEvents Label6 As System.Windows.Forms.Label
    Friend WithEvents Label7 As System.Windows.Forms.Label
    Friend WithEvents Label8 As System.Windows.Forms.Label
    Private WithEvents DataSocket1 As NationalInstruments.Net.DataSocket
    Friend WithEvents Switch1 As NationalInstruments.UI.WindowsForms.Switch
    Friend WithEvents Switch2 As NationalInstruments.UI.WindowsForms.Switch
    Friend WithEvents Marcha As NationalInstruments.UI.WindowsForms.Switch
    Friend WithEvents Switch5 As NationalInstruments.UI.WindowsForms.Switch
    Friend WithEvents DataSocket2 As NationalInstruments.Net.DataSocket
    Friend WithEvents DataSocket3 As NationalInstruments.Net.DataSocket
    Friend WithEvents DataSocket4 As NationalInstruments.Net.DataSocket
    Friend WithEvents Switch3 As NationalInstruments.UI.WindowsForms.Switch
    Friend WithEvents Label5 As System.Windows.Forms.Label
    Friend WithEvents Switch4 As NationalInstruments.UI.WindowsForms.Switch
    Friend WithEvents Label9 As System.Windows.Forms.Label
    Friend WithEvents DataSocket5 As NationalInstruments.Net.DataSocket
    Friend WithEvents DataSocket6 As NationalInstruments.Net.DataSocket
    Friend WithEvents DataSocket7 As NationalInstruments.Net.DataSocket
    Friend WithEvents Switch6 As NationalInstruments.UI.WindowsForms.Switch
    Friend WithEvents Label10 As System.Windows.Forms.Label
    Friend WithEvents DataSocket8 As NationalInstruments.Net.DataSocket
    Private Const BufferSize As Integer = 40

#Region " Windows Form Designer generated code "
    'Form overrides dispose to clean up the component list.
    Protected Overloads Overrides Sub Dispose(ByVal disposing As Boolean)
        If disposing Then
            If Not (components Is Nothing) Then
                components.Dispose()
            End If
        End If
        MyBase.Dispose(disposing)
    End Sub

    'Required by the Windows Form Designer
    Private components As System.ComponentModel.IContainer
```

'NOTE: The following procedure is required by the Windows Form Designer

'It can be modified using the Windows Form Designer.

'Do not modify it using the code editor.

Private WithEvents dataSocket As NationalInstruments.Net.DataSocket

Private WithEvents timer As System.Windows.Forms.Timer

Private WithEvents disconnectButton As System.Windows.Forms.Button

Private WithEvents connectAutoUpdateButton As System.Windows.Forms.Button

Private WithEvents dataSocketServer As NationalInstruments.Net.DataSocketServer

```
<System.Diagnostics.DebuggerStepThrough()> Private Sub InitializeComponent()  
    Me.components = New System.ComponentModel.Container()  
    Dim resources As System.ComponentModel.ComponentResourceManager = New System.ComponentModel.  
ComponentResourceManager(GetType(MainForm))  
    Me.dataSocket = New NationalInstruments.Net.DataSocket(Me.components)  
    Me.timer = New System.Windows.Forms.Timer(Me.components)  
    Me.disconnectButton = New System.Windows.Forms.Button()  
    Me.connectAutoUpdateButton = New System.Windows.Forms.Button()  
    Me.dataSocketServer = New NationalInstruments.Net.DataSocketServer(Me.components)  
    Me.waveformPlot = New NationalInstruments.UI.WaveformPlot()  
    Me.xAxis = New NationalInstruments.UI.XAxis()  
    Me.yAxis = New NationalInstruments.UI.YAxis()  
    Me.statusTextBox = New System.Windows.Forms.TextBox()  
    Me.statusLabel = New System.Windows.Forms.Label()  
    Me.Velocidad = New NationalInstruments.UI.WindowsForms.Knob()  
    Me.Label1 = New System.Windows.Forms.Label()  
    Me.Label2 = New System.Windows.Forms.Label()  
    Me.Label3 = New System.Windows.Forms.Label()  
    Me.Label4 = New System.Windows.Forms.Label()  
    Me.Label6 = New System.Windows.Forms.Label()  
    Me.Label7 = New System.Windows.Forms.Label()  
    Me.Label8 = New System.Windows.Forms.Label()  
    Me.DataSocket1 = New NationalInstruments.Net.DataSocket(Me.components)  
    Me.Switch1 = New NationalInstruments.UI.WindowsForms.Switch()  
    Me.Switch2 = New NationalInstruments.UI.WindowsForms.Switch()  
    Me.Marcha = New NationalInstruments.UI.WindowsForms.Switch()  
    Me.Switch5 = New NationalInstruments.UI.WindowsForms.Switch()  
    Me.DataSocket2 = New NationalInstruments.Net.DataSocket(Me.components)  
    Me.DataSocket3 = New NationalInstruments.Net.DataSocket(Me.components)  
    Me.DataSocket4 = New NationalInstruments.Net.DataSocket(Me.components)  
    Me.Switch3 = New NationalInstruments.UI.WindowsForms.Switch()  
    Me.Label5 = New System.Windows.Forms.Label()  
    Me.Switch4 = New NationalInstruments.UI.WindowsForms.Switch()  
    Me.Label9 = New System.Windows.Forms.Label()  
    Me.DataSocket5 = New NationalInstruments.Net.DataSocket(Me.components)  
    Me.DataSocket6 = New NationalInstruments.Net.DataSocket(Me.components)  
    Me.DataSocket7 = New NationalInstruments.Net.DataSocket(Me.components)  
    Me.Switch6 = New NationalInstruments.UI.WindowsForms.Switch()  
    Me.Label10 = New System.Windows.Forms.Label()  
    Me.DataSocket8 = New NationalInstruments.Net.DataSocket(Me.components)  
    CType(Me.dataSocket, System.ComponentModel.ISupportInitialize).BeginInit()  
    CType(Me.dataSocketServer, System.ComponentModel.ISupportInitialize).BeginInit()  
    CType(Me.Velocidad, System.ComponentModel.ISupportInitialize).BeginInit()  
    CType(Me.DataSocket1, System.ComponentModel.ISupportInitialize).BeginInit()  
    CType(Me.Switch1, System.ComponentModel.ISupportInitialize).BeginInit()  
    CType(Me.Switch2, System.ComponentModel.ISupportInitialize).BeginInit()  
    CType(Me.Marcha, System.ComponentModel.ISupportInitialize).BeginInit()  
    CType(Me.Switch5, System.ComponentModel.ISupportInitialize).BeginInit()  
    CType(Me.DataSocket2, System.ComponentModel.ISupportInitialize).BeginInit()  
    CType(Me.DataSocket3, System.ComponentModel.ISupportInitialize).BeginInit()  
    CType(Me.DataSocket4, System.ComponentModel.ISupportInitialize).BeginInit()  
    CType(Me.Switch3, System.ComponentModel.ISupportInitialize).BeginInit()  
    CType(Me.Switch4, System.ComponentModel.ISupportInitialize).BeginInit()  
    CType(Me.DataSocket5, System.ComponentModel.ISupportInitialize).BeginInit()  
    CType(Me.DataSocket6, System.ComponentModel.ISupportInitialize).BeginInit()  
    CType(Me.DataSocket7, System.ComponentModel.ISupportInitialize).BeginInit()  
    CType(Me.Switch6, System.ComponentModel.ISupportInitialize).BeginInit()  
    CType(Me.DataSocket8, System.ComponentModel.ISupportInitialize).BeginInit()  
    Me.SuspendLayout()  
    ,  
    'dataSocket  
    ,  
    Me.dataSocket.AutoConnect = False  
    ,  
    'timer
```

```
,
Me.timer.Enabled = True
,
'disconnectButton
,
Me.disconnectButton.BackColor = System.Drawing.Color.Orange
Me.disconnectButton.FlatStyle = System.Windows.Forms.FlatStyle.System
Me.disconnectButton.Font = New System.Drawing.Font("Impact", 9.75!, System.Drawing.FontStyle.Regular,
System.Drawing.GraphicsUnit.Point, CType(0, Byte))
Me.disconnectButton.ForeColor = System.Drawing.Color.LawnGreen
Me.disconnectButton.Location = New System.Drawing.Point(837, 510)
Me.disconnectButton.Name = "disconnectButton"
Me.disconnectButton.Size = New System.Drawing.Size(169, 57)
Me.disconnectButton.TabIndex = 23
Me.disconnectButton.Text = "Disconnect"
Me.disconnectButton.UseVisualStyleBackColor = False
,
'connectAutoUpdateButton
,
Me.connectAutoUpdateButton.FlatStyle = System.Windows.Forms.FlatStyle.System
Me.connectAutoUpdateButton.Font = New System.Drawing.Font("Impact", 10.0!, System.Drawing.FontStyle.
Underline, System.Drawing.GraphicsUnit.Point, CType(0, Byte))
Me.connectAutoUpdateButton.ForeColor = System.Drawing.Color.LawnGreen
Me.connectAutoUpdateButton.Location = New System.Drawing.Point(837, 175)
Me.connectAutoUpdateButton.Name = "connectAutoUpdateButton"
Me.connectAutoUpdateButton.Size = New System.Drawing.Size(165, 57)
Me.connectAutoUpdateButton.TabIndex = 20
Me.connectAutoUpdateButton.Text = "Connect (Auto Update)"
,
'waveformPlot
,
Me.waveformPlot.XAxis = Me.xAxis
Me.waveformPlot.YAxis = Me.yAxis
,
'statusTextBox
,
Me.statusTextBox.Anchor = CType(((System.Windows.Forms.AnchorStyles.Top Or System.Windows.Forms.
AnchorStyles.Left) _
Or System.Windows.Forms.AnchorStyles.Right), System.Windows.Forms.AnchorStyles)
Me.statusTextBox.Location = New System.Drawing.Point(140, 82)
Me.statusTextBox.Name = "statusTextBox"
Me.statusTextBox.ReadOnly = True
Me.statusTextBox.Size = New System.Drawing.Size(1013, 20)
Me.statusTextBox.TabIndex = 18
,
'statusLabel
,
Me.statusLabel.Location = New System.Drawing.Point(55, 85)
Me.statusLabel.Name = "statusLabel"
Me.statusLabel.Size = New System.Drawing.Size(48, 23)
Me.statusLabel.TabIndex = 16
Me.statusLabel.Text = "Status:"
,
'Velocidad
,
Me.Velocidad.Location = New System.Drawing.Point(1050, 381)
Me.Velocidad.Name = "Velocidad"
Me.Velocidad.Range = New NationalInstruments.UI.Range(0.0R, 50.0R)
Me.Velocidad.Size = New System.Drawing.Size(160, 152)
Me.Velocidad.TabIndex = 31
,
'Label1
,
Me.Label1.AutoSize = True
Me.Label1.Font = New System.Drawing.Font("Microsoft Sans Serif", 12.0!, System.Drawing.FontStyle.
Regular, System.Drawing.GraphicsUnit.Point, CType(0, Byte))
Me.Label1.ForeColor = System.Drawing.Color.DodgerBlue
Me.Label1.Location = New System.Drawing.Point(854, 356)
Me.Label1.Name = "Label1"
Me.Label1.Size = New System.Drawing.Size(163, 20)
Me.Label1.TabIndex = 32
Me.Label1.Text = "Cosigna de Velocidad"
,
'Label2
```

```
,
Me.Label2.AutoSize = True
Me.Label2.Font = New System.Drawing.Font("Impact", 20.0!, System.Drawing.FontStyle.Bold, System.
Drawing.GraphicsUnit.Point, CType(0, Byte))
Me.Label2.ForeColor = System.Drawing.Color.Crimson
Me.Label2.Location = New System.Drawing.Point(363, 23)
Me.Label2.Name = "Label2"
Me.Label2.Size = New System.Drawing.Size(465, 34)
Me.Label2.TabIndex = 33
Me.Label2.Text = "COMUNICACION S7-1200 A ABB ACS355"
,
'Label3
,
Me.Label3.AutoSize = True
Me.Label3.Font = New System.Drawing.Font("Microsoft Sans Serif", 12.0!, System.Drawing.FontStyle.
Regular, System.Drawing.GraphicsUnit.Point, CType(0, Byte))
Me.Label3.ForeColor = System.Drawing.Color.DodgerBlue
Me.Label3.Location = New System.Drawing.Point(352, 336)
Me.Label3.Name = "Label3"
Me.Label3.Size = New System.Drawing.Size(138, 20)
Me.Label3.TabIndex = 44
Me.Label3.Text = "Palabra de Mando"
,
'Label4
,
Me.Label4.AutoSize = True
Me.Label4.Font = New System.Drawing.Font("Microsoft Sans Serif", 10.0!, System.Drawing.FontStyle.Bold,
System.Drawing.GraphicsUnit.Point, CType(0, Byte))
Me.Label4.Location = New System.Drawing.Point(37, 536)
Me.Label4.Name = "Label4"
Me.Label4.Size = New System.Drawing.Size(72, 17)
Me.Label4.TabIndex = 45
Me.Label4.Text = "MARCHA"
,
'Label6
,
Me.Label6.AutoSize = True
Me.Label6.Font = New System.Drawing.Font("Microsoft Sans Serif", 10.0!, System.Drawing.FontStyle.Bold,
System.Drawing.GraphicsUnit.Point, CType(0, Byte))
Me.Label6.Location = New System.Drawing.Point(336, 536)
Me.Label6.Name = "Label6"
Me.Label6.Size = New System.Drawing.Size(80, 17)
Me.Label6.TabIndex = 47
Me.Label6.Text = "REVERSA"
,
'Label7
,
Me.Label7.AutoSize = True
Me.Label7.Font = New System.Drawing.Font("Microsoft Sans Serif", 10.0!, System.Drawing.FontStyle.Bold,
System.Drawing.GraphicsUnit.Point, CType(0, Byte))
Me.Label7.Location = New System.Drawing.Point(155, 339)
Me.Label7.Name = "Label7"
Me.Label7.Size = New System.Drawing.Size(68, 17)
Me.Label7.TabIndex = 48
Me.Label7.Text = "ENABLE"
,
'Label8
,
Me.Label8.AutoSize = True
Me.Label8.Font = New System.Drawing.Font("Microsoft Sans Serif", 10.0!, System.Drawing.FontStyle.Bold,
System.Drawing.GraphicsUnit.Point, CType(0, Byte))
Me.Label8.Location = New System.Drawing.Point(1142, 280)
Me.Label8.Name = "Label8"
Me.Label8.Size = New System.Drawing.Size(68, 17)
Me.Label8.TabIndex = 49
Me.Label8.Text = "ENABLE"
,
'DataSocket1
,
Me.DataSocket1.AccessMode = NationalInstruments.Net.AccessMode.ReadWriteAutoUpdate
Me.DataSocket1.AutoConnect = False
Me.DataSocket1.ReadMode = NationalInstruments.Net.ReadMode.Synchronous
Me.DataSocket1.Url = "opc://localhost/National Instruments.NIOPCServers.V5/MICRO850.MICRO850_ACS355.
VEL" & _
```



```
"OCIDAD_ENABLE"  
,  
'Switch1  
,  
Me.Switch1.Location = New System.Drawing.Point(1145, 136)  
Me.Switch1.Name = "Switch1"  
Me.Switch1.OffColor = System.Drawing.SystemColors.ActiveCaptionText  
Me.Switch1.OnColor = System.Drawing.SystemColors.Highlight  
Me.Switch1.Size = New System.Drawing.Size(64, 96)  
Me.Switch1.SwitchStyle = NationalInstruments.UI.SwitchStyle.VerticalToggle3D  
Me.Switch1.TabIndex = 50  
,  
'Switch2  
,  
Me.Switch2.Location = New System.Drawing.Point(158, 223)  
Me.Switch2.Name = "Switch2"  
Me.Switch2.OffColor = System.Drawing.SystemColors.ActiveCaptionText  
Me.Switch2.OnColor = System.Drawing.SystemColors.MenuHighlight  
Me.Switch2.Size = New System.Drawing.Size(64, 96)  
Me.Switch2.SwitchStyle = NationalInstruments.UI.SwitchStyle.VerticalToggle3D  
Me.Switch2.TabIndex = 51  
,  
'Marcha  
,  
Me.Marcha.Location = New System.Drawing.Point(39, 437)  
Me.Marcha.Name = "Marcha"  
Me.Marcha.OffColor = System.Drawing.SystemColors.ActiveCaptionText  
Me.Marcha.OnColor = System.Drawing.SystemColors.Highlight  
Me.Marcha.Size = New System.Drawing.Size(64, 96)  
Me.Marcha.SwitchStyle = NationalInstruments.UI.SwitchStyle.VerticalToggle3D  
Me.Marcha.TabIndex = 52  
,  
'Switch5  
,  
Me.Switch5.Location = New System.Drawing.Point(339, 437)  
Me.Switch5.Name = "Switch5"  
Me.Switch5.OffColor = System.Drawing.SystemColors.ActiveCaptionText  
Me.Switch5.OnColor = System.Drawing.SystemColors.MenuHighlight  
Me.Switch5.Size = New System.Drawing.Size(64, 96)  
Me.Switch5.SwitchStyle = NationalInstruments.UI.SwitchStyle.VerticalToggle3D  
Me.Switch5.TabIndex = 54  
,  
'Switch3  
,  
Me.Switch3.Location = New System.Drawing.Point(534, 381)  
Me.Switch3.Name = "Switch3"  
Me.Switch3.OffColor = System.Drawing.SystemColors.ActiveCaptionText  
Me.Switch3.OnColor = System.Drawing.SystemColors.Highlight  
Me.Switch3.Size = New System.Drawing.Size(64, 96)  
Me.Switch3.SwitchStyle = NationalInstruments.UI.SwitchStyle.VerticalToggle3D  
Me.Switch3.TabIndex = 55  
,  
'Label15  
,  
Me.Label15.AutoSize = True  
Me.Label15.Font = New System.Drawing.Font("Microsoft Sans Serif", 10.0!, System.Drawing.FontStyle.Bold, System.Drawing.GraphicsUnit.Point, CType(0, Byte))  
, System.Drawing.GraphicsUnit.Point, CType(0, Byte))  
Me.Label15.Location = New System.Drawing.Point(502, 521)  
Me.Label15.Name = "Label15"  
Me.Label15.Size = New System.Drawing.Size(120, 17)  
Me.Label15.TabIndex = 56  
Me.Label15.Text = "INICIAR TRAMA"  
,  
'Switch4  
,  
Me.Switch4.Location = New System.Drawing.Point(534, 175)  
Me.Switch4.Name = "Switch4"  
Me.Switch4.OffColor = System.Drawing.SystemColors.ActiveCaptionText  
Me.Switch4.OnColor = System.Drawing.SystemColors.Highlight  
Me.Switch4.Size = New System.Drawing.Size(64, 96)  
Me.Switch4.SwitchStyle = NationalInstruments.UI.SwitchStyle.VerticalToggle3D  
Me.Switch4.TabIndex = 57  
,  
'Label19
```

```
,
    Me.Label9.AutoSize = True
    Me.Label9.Font = New System.Drawing.Font("Microsoft Sans Serif", 10.0!, System.Drawing.FontStyle.Bold, System.Drawing.GraphicsUnit.Point, CType(0, Byte))
    Me.Label9.Location = New System.Drawing.Point(524, 339)
    Me.Label9.Name = "Label9"
    Me.Label9.Size = New System.Drawing.Size(74, 17)
    Me.Label9.TabIndex = 58
    Me.Label9.Text = "MODBUS"
    ,
    'Switch6
    ,
    Me.Switch6.Location = New System.Drawing.Point(192, 437)
    Me.Switch6.Name = "Switch6"
    Me.Switch6.OffColor = System.Drawing.SystemColors.ActiveCaptionText
    Me.Switch6.OnColor = System.Drawing.SystemColors.MenuHighlight
    Me.Switch6.Size = New System.Drawing.Size(64, 96)
    Me.Switch6.SwitchStyle = NationalInstruments.UI.SwitchStyle.VerticalToggle3D
    Me.Switch6.TabIndex = 59
    ,
    'Label10
    ,
    Me.Label10.AutoSize = True
    Me.Label10.Font = New System.Drawing.Font("Microsoft Sans Serif", 10.0!, System.Drawing.FontStyle.Bold, System.Drawing.GraphicsUnit.Point, CType(0, Byte))
    Me.Label10.Location = New System.Drawing.Point(189, 536)
    Me.Label10.Name = "Label10"
    Me.Label10.Size = New System.Drawing.Size(51, 17)
    Me.Label10.TabIndex = 60
    Me.Label10.Text = "PARO"
    ,
    'MainForm
    ,
    Me.AutoScaleDimensions = New System.Drawing.SizeF(96.0!, 96.0!)
    Me.AutoScaleMode = System.Windows.Forms.AutoScaleMode.Dpi
    Me.ClientSize = New System.Drawing.Size(1238, 593)
    Me.Controls.Add(Me.Label10)
    Me.Controls.Add(Me.Switch6)
    Me.Controls.Add(Me.Label9)
    Me.Controls.Add(Me.Switch4)
    Me.Controls.Add(Me.Label5)
    Me.Controls.Add(Me.Switch3)
    Me.Controls.Add(Me.Switch5)
    Me.Controls.Add(Me.Marcha)
    Me.Controls.Add(Me.Switch2)
    Me.Controls.Add(Me.Switch1)
    Me.Controls.Add(Me.Label8)
    Me.Controls.Add(Me.Label7)
    Me.Controls.Add(Me.Label6)
    Me.Controls.Add(Me.Label4)
    Me.Controls.Add(Me.Label3)
    Me.Controls.Add(Me.Label2)
    Me.Controls.Add(Me.Label1)
    Me.Controls.Add(Me.Velocidad)
    Me.Controls.Add(Me.statusLabel)
    Me.Controls.Add(Me.statusTextBox)
    Me.Controls.Add(Me.disconnectButton)
    Me.Controls.Add(Me.connectAutoUpdateButton)
    Me.Icon = CType(resources.GetObject("$this.Icon"), System.Drawing.Icon)
    Me.MinimumSize = New System.Drawing.Size(500, 350)
    Me.Name = "MainForm"
    Me.Text = "DataSocket Writer"
    CType(Me.dataSocket, System.ComponentModel.ISupportInitialize).EndInit()
    CType(Me.dataSocketServer, System.ComponentModel.ISupportInitialize).EndInit()
    CType(Me.Velocidad, System.ComponentModel.ISupportInitialize).EndInit()
    CType(Me.DataSocket1, System.ComponentModel.ISupportInitialize).EndInit()
    CType(Me.Switch1, System.ComponentModel.ISupportInitialize).EndInit()
    CType(Me.Switch2, System.ComponentModel.ISupportInitialize).EndInit()
    CType(Me.Marcha, System.ComponentModel.ISupportInitialize).EndInit()
    CType(Me.Switch5, System.ComponentModel.ISupportInitialize).EndInit()
    CType(Me.DataSocket2, System.ComponentModel.ISupportInitialize).EndInit()
    CType(Me.DataSocket3, System.ComponentModel.ISupportInitialize).EndInit()
    CType(Me.DataSocket4, System.ComponentModel.ISupportInitialize).EndInit()
    CType(Me.Switch3, System.ComponentModel.ISupportInitialize).EndInit()
```

```
CType(Me.Switch4, System.ComponentModel.ISupportInitialize).EndInit()  
CType(Me.DataSocket5, System.ComponentModel.ISupportInitialize).EndInit()  
CType(Me.DataSocket6, System.ComponentModel.ISupportInitialize).EndInit()  
CType(Me.DataSocket7, System.ComponentModel.ISupportInitialize).EndInit()  
CType(Me.Switch6, System.ComponentModel.ISupportInitialize).EndInit()  
CType(Me.DataSocket8, System.ComponentModel.ISupportInitialize).EndInit()  
Me.ResumeLayout(False)  
Me.PerformLayout()
```

End Sub

#End Region

```
<STAThread> _  
Public Shared Sub Main()  
    Application.EnableVisualStyles()  
    Application.DoEvents()  
    Application.Run(New MainForm())  
End Sub
```

```
Public Sub New()  
    MyBase.New()
```

```
    InitializeComponent()  
    dataSocket.Data.Attributes.Add("Frequency", CType(Velocidad.Value, Double))  
    dataSocket.Data.Attributes.Add("Timestamp", DateTime.Now)  
    DataSocket1.Data.Attributes.Add("InVelocidad", CType(Switch1.Value, Boolean))  
End Sub
```

```
Private Sub OnConnectAutoUpdateClick(ByVal sender As Object, ByVal e As System.EventArgs) Handles  
connectAutoUpdateButton.Click ✎  
    If dataSocket.IsConnected Then  
        dataSocket.Disconnect()  
    End If  
  
    dataSocket.Connect(TargetUrl, AccessMode.WriteAutoUpdate)  
End Sub
```

```
Private Sub OnDisconnectClick(ByVal sender As Object, ByVal e As System.EventArgs) Handles  
disconnectButton.Click ✎  
    dataSocket.Disconnect()  
End Sub
```

```
Private Sub OnDataSocketConnectionStatusUpdated(ByVal sender As Object, ByVal e As NationalInstruments.  
Net.ConnectionStatusUpdatedEventArgs) Handles dataSocket.ConnectionStatusUpdated ✎  
    statusTextBox.Text = e.Message  
End Sub
```

```
Private Sub targetTextBox_TextChanged(sender As Object, e As EventArgs)  
  
End Sub
```

```
Private Sub frequencyLabel_Click(sender As Object, e As EventArgs)  
  
End Sub
```

```
Private Sub statusTextBox_TextChanged(sender As Object, e As EventArgs)  
  
End Sub
```

```
Private Sub generateDataCheckBox_CheckedChanged(sender As Object, e As EventArgs)  
  
End Sub
```

```
Private Sub Knob1_AfterChangeValue(sender As Object, e As AfterChangeNumericValueEventArgs) Handles  
Velocidad.AfterChangeValue ✎
```

```
    Dim frequencyValue As Double = CType(Velocidad.Value, Double)
    dataSocket.Data.Value = frequencyValue
    dataSocket.Data.Attributes.Item("Frequency").Value = frequencyValue
End Sub

Private Sub dataSocket_DataUpdated(sender As Object, e As DataUpdatedEventArgs) Handles dataSocket.
DataUpdated
End Sub

Private Sub Label1_Click(sender As Object, e As EventArgs) Handles Label1.Click
End Sub

Private Sub Label3_Click(sender As Object, e As EventArgs)
End Sub

Private Sub TextBox1_TextChanged(sender As Object, e As EventArgs)
End Sub

Private Sub Label3_Click_1(sender As Object, e As EventArgs) Handles Label3.Click
End Sub

Private Sub Label7_Click(sender As Object, e As EventArgs) Handles Label7.Click
End Sub

Private Sub VELOCIDAD_ENABLE_Click(sender As Object, e As EventArgs)
End Sub

Private Sub NumericEdit1_AfterChangeValue(sender As Object, e As AfterChangeNumericValueEventArgs)
End Sub

Private Sub statusTextBox_TextChanged_1(sender As Object, e As EventArgs) Handles statusTextBox.
TextChanged
End Sub

Private Sub DataSocket1_DataUpdated(sender As Object, e As DataUpdatedEventArgs) Handles DataSocket1.
DataUpdated
End Sub

Private Sub timer_Tick(sender As Object, e As EventArgs) Handles timer.Tick
End Sub

Private Sub Switch1_StateChanged(sender As Object, e As ActionEventArgs) Handles Switch1.StateChanged
    DataSocket1.Connect(TargetUr15, AccessMode.WriteAutoUpdate)
    If (Switch1.Value = True) Then
        DataSocket1.Data.Value = 1
    Else
        DataSocket1.Data.Value = 0
    End If
End Sub

Private Sub Label8_Click(sender As Object, e As EventArgs) Handles Label8.Click
End Sub

Private Sub Switch2_StateChanged(sender As Object, e As ActionEventArgs) Handles Switch2.StateChanged
    DataSocket2.Connect(TargetUr11, AccessMode.WriteAutoUpdate)
    If (Switch2.Value = True) Then
        DataSocket2.Data.Value = 1
    End If
End Sub
```

```
    Else
        DataSocket2.Data.Value = 0
    End If

End Sub

Private Sub Switch5_StateChanged(sender As Object, e As EventArgs) Handles Switch5.StateChanged
    DataSocket4.Connect(TargetUr14, AccessMode.WriteAutoUpdate)
    If (Switch5.Value = True) Then
        DataSocket4.Data.Value = 1
    Else
        DataSocket4.Data.Value = 0
    End If
End Sub

Private Sub Switch4_StateChanged(sender As Object, e As EventArgs) Handles Switch4.StateChanged
    DataSocket5.Connect(TargetUr13, AccessMode.WriteAutoUpdate)
    If (Switch4.Value = True) Then
        DataSocket5.Data.Value = 1
    Else
        DataSocket5.Data.Value = 0
    End If
End Sub

Private Sub Switch3_StateChanged_1(sender As Object, e As EventArgs) Handles Switch3.StateChanged
    DataSocket7.Connect(TargetUr16, AccessMode.WriteAutoUpdate)
    If (Switch3.Value = True) Then
        DataSocket7.Data.Value = 1
    Else
        DataSocket7.Data.Value = 0
    End If
End Sub

Private Sub Marcha_StateChanged(sender As Object, e As EventArgs) Handles Marcha.StateChanged
    DataSocket6.Connect(TargetUr12, AccessMode.WriteAutoUpdate)
    If (Marcha.Value = True) Then
        DataSocket6.Data.Value = 1
    Else
        DataSocket6.Data.Value = 0
    End If
End Sub

Private Sub Label10_Click(sender As Object, e As EventArgs) Handles Label10.Click

End Sub

Private Sub Switch6_StateChanged(sender As Object, e As EventArgs) Handles Switch6.StateChanged
    DataSocket8.Connect(TargetUr17, AccessMode.WriteAutoUpdate)
    If (Switch6.Value = True) Then
        DataSocket8.Data.Value = 1
    Else
        DataSocket8.Data.Value = 0
    End If
End Sub
End Class
```

```
using System;
using System.Collections.Generic;
using System.Linq;
using System.Web;
using System.Web.UI;
using System.Web.UI.WebControls;
using System.Diagnostics;

namespace WebApplication1
{
    public partial class WebForm1 : System.Web.UI.Page
    {
        protected void Page_Load(object sender, EventArgs e)
        {
            Process.Start("C:\\Users\\Laboratorio\\Desktop\\MODBUS\\OPC\\PROGRAMA_OPC_VB\\Micro850_V_20\\vb\\
Writer\\Micro850_V_20.vbproj");
        }
    }
}
```

```
<%@ Page Title="Home Page" Language="C#" MasterPageFile="~/Site.Master" AutoEventWireup="true" CodeBehind=
"Default.aspx.cs" Inherits="WebApplication1._Default" %>

<asp:Content ID="BodyContent" ContentPlaceHolderID="MainContent" runat="server">

    <div class="jumbotron text-center">
        <h2>ESCUELA SUPERIOR POLITECNICA DEL LITORAL</h2>
        <h2>Facultad de Ingeniería en Electricidad y Computación</h2>
        <p class="lead">Diseño e implementación de una red Modbus utilizando PLC's y VFD's de tecnología
Siemens, Allen Bradley y ABB.</p>
    </div>

    <div class="row">
        <div class="col-md-6">
            <h2>SIEMENS S7-1200</h2>
            <p>
                Aquí tendremos la comunicación con los VFD's: V20 y ACS355

            </p>
            <p>
                
            </p>
            <p ALIGN=center>
                <a class="btn btn-primary" href="S71200.aspx">Conectar S7-1200 &raquo;</a>
            </p>
        </div>
        <div class="col-md-6">
            <h2>MICRO 850</h2>
            <p>
                Aquí tendremos la comunicación con los VFD's: V20 y ACS355

            </p>
            <p>
                
            </p>
            <p ALIGN=center>
                <a class="btn btn-primary" href="MICRO850.aspx">Conectar micro485 &raquo;</a>
            </p>
        </div>
    </div>
</asp:Content>
```